

INTERIORS

Furniture, Accessories & Functional design

Caimi

PRICE LIST 24

Caimi Brevetti S.p.A.
Via Brodolini 25/27
20834 Nova Milanese (MB)
ITALY

Export department:
Tel. (Int. + 39) - 0362 - 491002
Fax (Int + 39) - 0362 - 491061
E-mail: export.dept@caimi.com

I prezzi sono in vigore dal 1 ottobre 2024
The prices are valid from 1st October 2024
Les prix sont valable au 1er Octobre 2024
Los precios entran en vigor a partir de 1º de octubre 2024
Die Preise sind ab 1. Oktober 2024 gültig

Ordine minimo e resa della merce: contattare il nostro ufficio commerciale export.
In caso di spedizioni in franco destino la consegna si intende ESCLUSIVAMENTE a bordo camion.

Minimum order and delivery term: please contact our Export Dept.
In case of delivery duty paid, the delivery is ONLY on board truck.

Minimum de commande et livraison: merci de contacter notre S.ce Export.
Pour expéditions en franco la livraison est SEULEMENT à bord camion.

Minimo de pedido y condiciones de entrega: contactar con nuestro Dpto. Exportacion.
En caso de expedición a franco destino, la entrega se efectua EXCLUSIVAMENTE a bordo del camion.

Mindestauftragswert und Lieferbedingungen: bitte setzen Sie sich in Verbindung mit unserer Verkaufsabteilung.
Für frei Haus Sendungen, ist die Lieferung NUR an Bord LKW.

LEGENDA

CD: Codice - Code - Code - Codigo - Artikelnummer

PR: Prezzo - Price - Prix - Precio - Preis

CL: Colore - Colour - Couleur - Colore - Farbe

DS: Descrizione - Description - Description - Descripción - Beschreibung

pcs: Pezzi - Pieces - Pièces - Piezas - Stückzahl

 : Portata max. - Maximum load - Charge utile - Peso max. - Tragfähigkeit

L: Capacità in litri - Capacity in liters - Capacité en litres - Capacidad en litros

- Kapazität in Liter

Socrate & Bibliotech p. 14



SOCRATE
p. 16



SOCRATE Wall
p. 40

Socrate Outdoor p. 50



SOCRATE Outdoor
p. 52

Big p. 56



BIG
p. 58

Public Seating p. 114



KALEIDOS Beam
p. 116



ULISSE
p. 118

Tables p. 64



Clicca e vai alla
pagina selezionata.

Click and go to the
selected page.



PEGASO Glass
p. 66



PEGASO Infinito
p. 90



PEGASO Metal
p. 76



PEGASO Cemento
p. 74



PEGASO Wood
p. 78



PEGASO Solid
p. 72



SUSU
p. 100



JOLLY
p. 94



CICERONE
p. 98

Versatile seating & Seating p. 102



STILEMI
p. 104



SHOPPER
p. 106



KALEIDOS
p. 108

Dividers p. 122



CLIP
p. 126



ARIANNA
p. 124

Communication & Meeting p. 134



MEETING
p. 158



SPEECH
p. 154

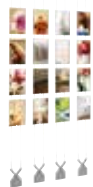

KOALA
p. 136



KOALA Totem p. 148
BATTISTA Totem p. 145



BATTISTA Stanchion
p. 146



SET
p. 150



GASTONE
p. 153

Recycling p. 160



Clicca e vai alla
pagina selezionata.

Click and go to the
selected page.



LINEAR
p. 170



BINZ
p. 164



MAXI
p. 162



MAXIMO
p. 169



MAXIMO Lock
p. 169



MAXIMO Modular
p. 165



CENTOLITRI
p. 166



CENTOLITRI Lock
p. 168



PRISMA
p. 174



Clicca e vai alla pagina selezionata.

Click and go to the selected page.

Accessories p. 178



LUTHEA
p. 180



STELLA
p. 185



MET'ALL
p. 181



SWING
p. 186



QUADRANGOLO
p. 185



GIOIA
p. 188



ELK
p. 187



EVA
p. 188



KING
p. 187



MAESTRALE
p. 185



BATTISTA Color
p. 184



BATTISTA
p. 182



BATTISTA Hook
p. 182



HOOK
p. 189



DUO
p. 189

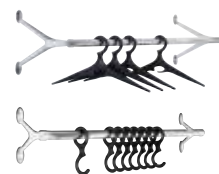

AMBROGIO
AMBROGINO
p. 191



OMETTO
HANGER
p. 192



RAPID
p. 190

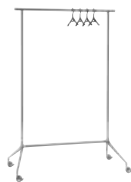

SPEECH Stander
p. 190



SWING
p. 195



HI-TECH
p. 194



DIVIDO
p. 195



DESIGN COLLECTION
p. 196



HI-TECH
p. 197

Accessories p. 178



PIOGGIA
p. 193



SET
p. 193



ESTERNO
p. 198



PIAZZA
p. 198



SMILE
p. 198

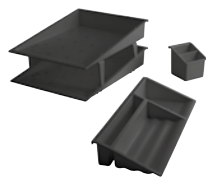

DESK-UP
p. 200



BISS
p. 199



UP
p. 199



HI-TECH
p. 199



OREDODICI
p. 199



ST DORFLES
p. 199



PLAT / KABO
p. 193

Lighting p. 202



Clicca e vai alla
pagina selezionata.

Click and go to the
selected page.



TELETA
p. 203



OPERA
p. 202

CAIMI BREVETTI

Made in Italy since 1949

I_Fondata nel 1949, Caimi è una delle principali realtà produttive europee design oriented nel settore dell'arredamento, dei complementi d'arredo e delle soluzioni acustiche per l'ufficio, la casa e il contract. Da **75 anni** Caimi continua a ricercare e sperimentare nuove soluzioni per migliorare concretamente la vita delle persone e gli ambienti in cui vivono. Grazie ad una sofisticata integrazione fra struttura produttiva e logistica, gestisce con successo una gamma di prodotti composta da oltre **3.500** articoli e **35.000** componenti, garantendo alla propria clientela tempi di consegna estremamente rapidi.

EN_Founded in 1949, Caimi is one of the leading European design-oriented manufacturers of furniture and complements for the office, home and contract sectors. For **75 years** Caimi has continued to research and assay new solutions for the betterment of people's lives and living spaces. Thanks to its sophisticated integration of production line work and logistics operations, Caimi can effect extremely fast deliveries of any orders from its product range, which is made up of around **3.500** items and more than **35.000** separate components.

F_Fondée en 1949, Caimi est l'une des principales entreprises européennes de production axée sur le design, dans le domaine de l'ameublement, des accessoires de décoration et des solutions acoustiques pour le bureau, la maison et les grands projets clé en main. Depuis **75 années**, Caimi est à la recherche de nouvelles solutions pour améliorer de manière concrète la vie des personnes et de leur habitat. Grâce à une intégration sophistiquée entre sa structure de production et la logistique, Caimi peut gérer avec succès une gamme d'environ **3.500** produits avec plus de **35.000** composants, assurant ainsi des délais de livraison extrêmement rapides à ses clients.

E_Fundada en 1949, Caimi es una de las principales empresas productoras europeas dedicada al diseño en el sector del interiorismo, de los complementos decorativos y de las soluciones acústicas para oficina, hogar y contract. Desde hace **75 años**, Caimi investiga y desarrolla, de forma continua, novedosas soluciones para mejorar el bienestar de las personas y el entorno en el que viven. Gracias a una integración avanzada entre estructura de producción y logística, gestiona exitosamente una gama de productos que consta de más de **3.500** artículos y **35.000** componentes, garantizando a sus clientes plazos de entrega sumamente rápidos.

D_1949 gegründet, ist Caimi eines der führenden Design-orientierten Hersteller in Europa in der Branche Einrichtung, Einrichtungszubehör und Schalldämpflösungen für Büro, Wohnen und Contract. Seit **75 Jahren** erforscht und experimentiert Caimi neue Lösungen, um das Leben der Menschen und die Räume, in denen sie leben, zu verbessern. Dank der hochentwickelten Integration zwischen Produktion und Logistik kann Caimi eine breite Palette an Produkten erfolgreich herstellen und vertreiben, die über **3.500** Produkte und **35.000** Komponenten miteinschließt, und somit den eigenen Kunden extrem schnelle Lieferzeiten garantieren.



**Download
Company
profile**



Clicca e vai alla
pagina selezionata.

Click and go to the
selected page.

AWARDS

Over 70 international awards

I_Le molteplici iniziative di Caimi nel design, nella ricerca e nella cultura hanno portato all'esposizione dei suoi prodotti presso mostre e musei e l'hanno vista protagonista di prestigiosi eventi e di importanti premi e riconoscimenti, tra i quali tre Premi Compasso d'Oro ADI, tre Menzione d'Onore al Compasso d'Oro ADI, il premio DesignEuropa Awards (assegnato dall'Ufficio dell'Unione Europea per la proprietà intellettuale, EUIPO), numerose selezioni ADI Design Index e tre German Design Award. Nel 2020 quattro prodotti Caimi sono entrati a far parte della collezione permanente di Arte e Design del Quirinale (Residenza del Presidente della Repubblica Italiana).

EN_Caimi's many initiatives in design, research and culture have led to the display of its products at exhibitions and museums while playing a leading role in prestigious events and receiving important prizes and awards, including three ADI Compasso d'Oro Awards, three ADI Compasso d'Oro Honourable Mentions, the DesignEuropa Awards (assigned by the European Union Intellectual Property Office, EUIPO), numerous ADI Design Index selections and three German Design Awards. In 2020, four Caimi products became part of the permanent collection of Art and Design at the Quirinale (Residence of the President of the Italian Republic).

F_Les nombreuses initiatives de Caimi dans le design, dans la recherche et dans la culture, ont permis d'exposer ses produits dans des expositions et des musées, et ont fait de Caimi une vedette prestigieuses lors d'événements, de prix et reconnaissances importants, dont trois Prix Compas d'Or ADI, trois Mentions d'honneur au Compas d'Or ADI, le prix DesignEuropa Awards (délivré par l'Office de l'Union européenne pour la propriété intellectuelle, EUIPO), de nombreuses sélections ADI Design Index et trois prix German Design Award. En 2020 quatre produits Caimi sont devenus partie intégrante de la collection permanente d'Art et Design du Quirinale (la résidence du Président de la République italienne).

E_Las numerosas iniciativas de Caimi en el ámbito del diseño, la investigación y la cultura han propiciado la exhibición de sus productos en exposiciones y museos y la han convertido en protagonista de prestigiosos eventos y en destinataria de importantes premios y reconocimientos, como tres Premios ADI Compasso d'Oro, tres Menciones de Honor ADI Compasso d'Oro, los Premios DesignEuropa (asignados por la Oficina de Propiedad Intelectual de la Unión Europea, EUIPO), numerosas selecciones ADI Design Index y tres German Design Awards. En 2020, cuatro productos Caimi pasaron a formar parte de la colección permanente de Arte y Diseño del Palacio del Quirinale (Residencia del Presidente de la República Italiana).

D_Dank der verschiedenen Initiativen von Caimi in den Bereichen Design, Forschung und Kultur sind die Produkte des Unternehmens auf zahlreichen Ausstellungen und in Museen zu besichtigen. Caimi ist außerdem häufig bei renommierten Veranstaltungen zu Gast und hat wichtige Preise und Auszeichnungen erhalten, darunter drei Compasso d'Oro ADI, drei lobende Erwähnungen zum Compasso d'Oro ADI, den ersten Platz bei den DesignEuropa Awards (vergeben vom Amt der Europäischen Union für geistiges Eigentum, EUIPO), zahlreiche Aufnahmen in den ADI Design Index und drei Designpreise der Bundesrepublik Deutschland. Im Jahr 2020 wurden vier Caimi-Produkte in die ständige Sammlung für Kunst und Design im Quirinalspalast (Amtssitz des italienischen Staatspräsidenten) aufgenommen.



I DESIGNERS SONO I NOSTRI OCCHI SUL MONDO

Designers are our eyes on the world

I I protagonisti del design industriale sono due: il progettista e l'azienda. Nel caso della Caimi il ruolo dei designer, nel rispetto dell'autonomia inventiva, è direttamente collegato con la costante innovazione tecnologica e di processo che sta dietro ogni prodotto. Da questa filosofia progettuale, discende un metodo particolare: il sapere e le soluzioni originali si costruiscono insieme, passo dopo passo, con accelerazioni, ripensamenti, intuizioni e nuovi paradigmi. Solo così è possibile costruire una relazione virtuosa e continua con ogni singolo designer, nel rispetto del ruolo di ciascuno. Lo stesso sistema di prodotti dell'azienda mette in evidenza l'identità e la riconoscibilità generale del marchio, da un lato, e dall'altro la singolarità di ciascuno dei progettisti coinvolti.

EN There are two central figures in the world of industrial design: the designer and the company. In the case of Caimi the role of the designers, with due respect of their inventive autonomy, is directly linked to the constant innovation of technology and process that lies behind every product. Out of this design philosophy comes a specific method: knowledge and original solutions are built together, step by step, with accelerations, afterthoughts, intuitions and new paradigms. Only in this way it is possible to construct a virtuous, ongoing relationship with each individual designer, respecting the role that each person has to play. The same system of company's products highlights, on the one side, the identity and general recognition of the brand, and on the other, the singularity of each of the designers involved.

F Les protagonistes du design industriel sont au nombre de deux: le concepteur et l'entreprise. Dans le cas de Caimi le rôle des concepteurs, tout en respectant leur autonomie inventive, est directement lié à l'innovation technologique et de processus constante, qui est à la base de chaque produit. Mais cette philosophie conceptuelle donne lieu à une méthode particulière: le savoir et les solutions originales se construisent ensemble, pas après pas, avec des accélérations, des remises en question, l'intuition et les nouveaux paradigmes. Ce n'est que de cette manière qu'il est possible de construire une relation vertueuse et continue avec chaque concepteur, en respectant le rôle de chacun. Le système des produits de l'entreprise met en évidence l'identité et la reconnaissance générale de la marque, d'une part, et le trait distinctif de chaque concepteur, d'autre part.

E El diseño industrial tiene dos protagonistas: el diseñador y la empresa. Para Caimi el papel del diseñador, siempre respetando su independencia creadora, está directamente vinculado a la constante innovación tecnológica y del proceso subyacentes a todo producto. De esta filosofía del diseño se desprende un método particular: el conocimiento y las soluciones originales se construyen juntos, paso a paso, con aceleraciones, replanteamientos, intuiciones y nuevos paradigmas. Tan sólo así se logra entablar una relación virtuosa y continua con cada diseñador, respetando el papel de cada uno. Hasta en el mismo sistema de productos de la empresa destaca la identidad y el reconocimiento general de la marca por una parte, y la individualidad de cada uno de los diseñadores involucrados por la otra.

D Im Industriedesign gibt es zwei Hauptakteure: Der Designer und das Unternehmen. Im Fall von Caimi verbindet sich die Rolle der Designer und die Achtung vor deren erfinderischer Freiheit mit der fortlaufenden Innovation von Technologien und Verfahren, die hinter jedem Produkt steht. Aus dieser Entwurfsphilosophie ergibt sich eine besondere Methode: das Wissen und die originellen Lösungen werden zusammen erarbeitet in einem schrittweisen Prozess, das Beschleunigungen wie Umdenken, Intuitionen und neue Paradigmen mit einschließt. Nur so kann man ein produktives und kontinuierliches Verhältnis zu jedem einzelnen Designer aufbauen, in dem die Rolle eines jeden geachtet wird. Selbst bei unserem Produktsystem stehen sowohl die Identität und allgemeine Erkennbarkeit der Marke als auch das individuelle Profil eines jeden der mitarbeitenden Designer gleichberechtigt im Vordergrund.

Acropoli
Sezgin Aksu
Alessandro Angelotti
Archistudio
Pietro Arosio
Stefano Barzaghi
Claudio Bellini
Mario Bellini
Chiara Bevegni
Claus Breinholt
Caimi Lab
Letterio Cardile
Aldo Cibic
Marco Cocco
Massimo Colagrande

Paul De Feiter
Michele De Lucchi
Gillo Dorfles
Frida Doveil
Giancarlo Fassina
Moreno Ferrari
Carlo Forcolini
Graziano Friscione
Hsiang Han Hsu
Ton Haas
Giulio Iacchetti
Id Vision
M+A+P Design Studio
Raffaello Manzoni
Alessandro Mendini

Atelier Mendini
Gianni Menguzzato
Claudio Nascimben
Philippe Nigro
Eleonore Peduzzi Riva
Pierandrei Associati
Francesco Radaelli
Matteo Ragni
Marc Sadler
Francesca Smiraglia
Lorenzo Stano
SI Design
Silvia Suardi
Mario Trimarchi
Alessandro Zambelli

SUSTAINABILITY

Environmentally conscious design

I_ Caimi, da sempre sensibile nei confronti delle tematiche ambientali e dell'ecosostenibilità, utilizza, dove tecnicamente possibile, materiali riciclati, riciclabili o riutilizzabili. La produzione è composta in prevalenza da oggetti monomaterici, che garantiscono una facile riciclabilità mentre gli oggetti composti da più materiali sono disassemblabili, consentendo di riciclare separatamente le singole parti. I sistemi modulari Caimi sono inoltre riconfigurabili e i singoli componenti sostituibili al fine di adeguarsi alle mutate esigenze degli ambienti in cui sono inseriti.

EN_ Caimi, which has always been sensitive to environmental issues and eco-sustainability, uses recycled, recyclable or reusable materials wherever technically possible. Production is mainly composed of single-material objects, which guarantee easy recyclability, while objects composed of several materials can be disassembled, allowing the individual parts to be recycled separately. Caimi's modular systems are also reconfigurable and individual components can be replaced in order to adapt to the changing needs of the environments they are placed in.

F_ Depuis toujours Caimi a été sensible aux thèmes de l'environnement et du développement durable, en utilisant des matériaux recyclés, recyclables ou réutilisables, lorsque c'est techniquement possible. La production est principalement composée d'objets monomatériaux, qui garantissent une recyclabilité aisée, tandis que les objets composés de plusieurs matériaux peuvent être désassemblés, ce qui permet de recycler les différentes parties séparément. Les systèmes modulaires Caimi peuvent également être reconfigurés et les différents composants remplaçables peuvent s'adapter à l'évolution des exigences des habitats où il sont utilisés.

E_ Caimi, que siempre ha sido sensible a las cuestiones medioambientales y de ecosostenibilidad, utiliza materiales reciclados, reciclables o reutilizables siempre que resulta técnicamente posible. La producción se compone principalmente de objetos elaborados en un material único, lo que garantiza una fácil reciclabilidad, mientras que los objetos compuestos de varios materiales son desensamblables, lo que permite reciclar cada una de sus partes por separado. Además, los sistemas modulares de Caimi son reconfigurables y sus componentes individuales pueden sustituirse para adaptarse a los eventuales cambios en las necesidades de los entornos en los que se integran.

D_ Caimi ist seit jeher mit Umweltthemen und der Umweltverträglichkeit vertraut und verwendet, wo technisch möglich, wiederverwertbare oder recyclebare Materialien. Die Produktion besteht überwiegend aus Monomaterial- Gegenständen, die leicht recyclebar sind: die Gegenstände aus mehreren Materialien sind zum Großteil so entwickelt, das sie auseinander gebaut werden können, wodurch das Recycling der einzelnen Komponenten ermöglicht wird. Die Produkte Snowsound Technology, die Snowsound Fiber Stoffe und Snowwall sind mit der Greenguard Gold-Zertifizierung ausgezeichnet worden, die die Anwendung von Materialien mit geringen chemischen Emissionen und deren Beitrag zur verbesserten Raumqualität bezeugt.



**Guarda
il video**



**Watch
the video**



Clicca e vai alla
pagina selezionata.

Click and go to the
selected page.



PRODOTTI “CAM”

I “CAM” Criteri Ambientali Minimi sono requisiti ambientali definiti per le varie fasi del processo di acquisto nel settore della pubblica amministrazione, volti a individuare la soluzione progettuale migliore sotto il profilo ambientale.

I numerosi prodotti Caimi che rispondono ai “CAM” Criteri Ambientali Minimi sono indicati nel presente listino con il seguente logo:

EN_The “CAM” Minimum Environmental Criteria are environmental requirements defined for the various phases of the purchasing process in the Italian public administration sector, aimed at identifying the best design solution from an environmental point of view.

The numerous Caimi products that meet the “CAM” Minimum Environmental Criteria are indicated in this price list with the following logo:



SOFTWARE DI PROGETTAZIONE

Planning software



I_pCon.planner è un software di progettazione di spazi, accessibile gratuitamente dal sito internet www.caimi.com, che permette di disegnare con facilità ambienti 3D e di arredarli con gli articoli Caimi. E' una soluzione professionale, ma intuitiva da utilizzare. Il formato nativo DWG permette una condivisione facile con altri applicativi. Il pratico catalogo online pCon.catalog, contiene numerose soluzioni di arredo in formato DWG, scaricabili ed utilizzabili direttamente nei progetti. Grazie al plug-in per AutoCAD e AutoCAD Architecture, tutti i simboli contenuti nel pCon.catalog possono essere scaricati, per poi essere elaborati, direttamente in AutoCAD.

EN_pCon.planner is a planning software, freely accessible from website [ww.caimi.com](http://www.caimi.com), allowing to easily plan 3D rooms and furnish them with Caimi Brevetti's products. It's a professional solution yet intuitive to use. The DWG native file format allows for easy sharing with other applications. The online catalog pCon.catalog, contains many design solutions in DWG, downloadable and usable in the projects. Thanks to the plug-in for AutoCAD and AutoCAD Architecture, all symbols contained in pCon.catalog can be downloaded, and then be processed directly in AutoCAD.

F_pCon.planner est un logiciel pour le projet des espaces, librement accessible du site internet www.caimi.com, qui permet de dessiner facilement des pièces en 3D et les meubler avec les produits Caimi. Il s'agit d'une solution professionnelle mais aussi intuitive à utiliser. Le format de fichier DWG natif permet de partager facilement avec d'autres applications. Le catalogue en ligne pCon.catalog contient de nombreuses solutions de conception au format DWG, téléchargeables et utilisables directement dans les projets. Merci à des plug-ins pour AutoCAD et AutoCAD Architecture, tous les symboles contenus dans pCon.catalog peuvent être téléchargés et traités directement dans AutoCAD.

E_pCon.planner es un software de diseño, accesible de forma gratuita en el sitio web www.caimi.com, que permite diseñar entornos 3D con facilidad y proporcionarlos con artículos Caimi. Es una solución profesional, pero de uso intuitivo. El formato DWG permite compartir fácilmente con otras aplicaciones. El simple catálogo en línea pCon.catalog contiene muchas soluciones de diseño en formato DWG, descargable y utilizable directamente en proyectos. Gracias a los plug-ins para AutoCAD y AutoCAD Architecture, todos los símbolos que figuran en pCon.catalog se pueden descargar, y luego se procesan directamente en AutoCAD.

D_pCon.planner ist eine Raumgestaltungssoftware auf die jederzeit von der Webseite www.caimi.com kostenlos zugegriffen werden kann. Diese Software bietet die Möglichkeit 3D Räume zu gestalten und diese mit Caimi Produkten einzurichten. Es handelt sich um eine sehr professionelle Lösung die jedoch intuitiv verwendet werden kann. Das DWG Dateiformat erlaubt eine sehr einfache Nutzung gemeinsam mit anderen Programmen. Der praktische Online-Katalog pCon.catalog beinhaltet unzählige Einrichtungslösungen im DWG-Format die direkt zur Verwendung für Projekte heruntergeladen können. Dank dem Plug-in für AutoCAD und AutoCAD Architecture können alle Symbole des Online-Katalog pCon.catalog heruntergeladen und danach direkt in AutoCAD bearbeitet werden.



SCHEDE TECNICHE E FILE DWG

Technical cards and DWG Files



I_Le schede tecniche (formato PDF), disponibili in italiano e inglese, e i file DWG dei nostri articoli sono scaricabili direttamente dal sito internet www.caimi.com

EN_The technical cards (.pdf files), available in Italian and English, and the DWG files of our products can be directly downloaded from website www.caimi.com

F_Les fiches techniques (fichier .pdf), disponibles en italien et anglais, et les dessins DWG de nos produits peuvent être téléchargés directement du site internet www.caimi.com

E_Las hojas de datos (formato PDF), disponibles en italiano y en inglés, y los dibujos DWG de nuestros productos se pueden descargar directamente desde el sitio web www.caimi.com

D_Die Datenblätter (im PDF-Format), die in den Sprachen englisch und italienisch verfügbar sind, und die DWG-Zeichnungen unserer Produkte können direkt auf der Webseite www.caimi.com heruntergeladen werden.

CATALOGHI

Catalogues



I_I cataloghi (formato PDF) sono scaricabili direttamente dal sito internet www.caimi.com

EN_The catalogues (.pdf files) can be seen in website www.caimi.com and directly downloaded.

F_Les catalogues (fichier .pdf) peuvent être feuilletés sur le site internet www.caimi.com et téléchargés directement.

E_Los catálogos (formato PDF) son navegables y descargable directamente desde el sitio web www.caimi.com directamente desde el sitio web www.caimi.com

D_Die Kataloge (im PDF-Format) können direkt auf der Website www.caimi.com durchgeblättert und heruntergeladen werden.

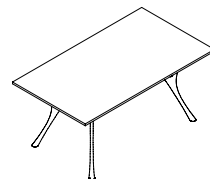
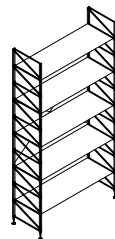
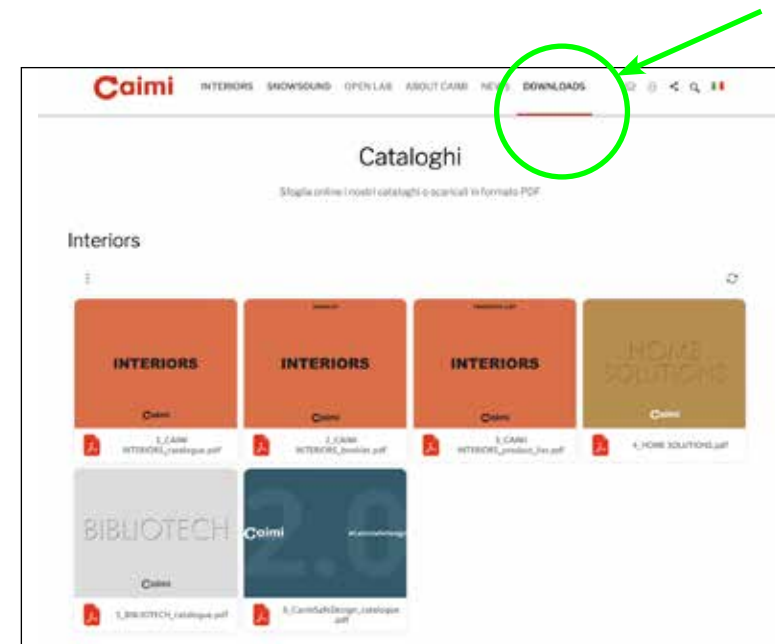
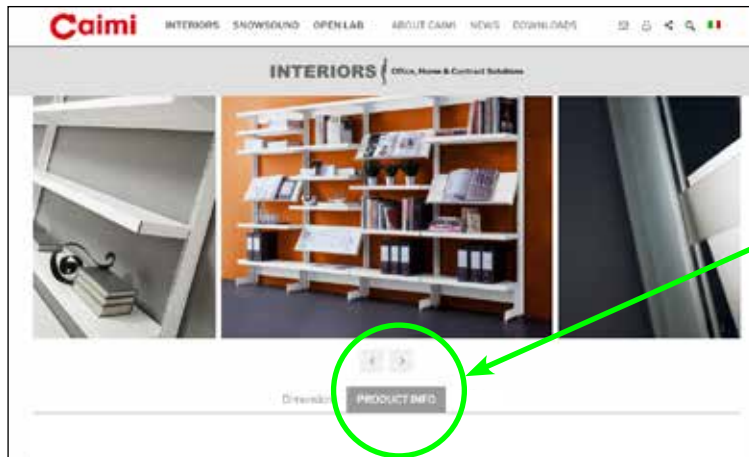

SOCRATE & BIBLIOTECH

design

Caimi Lab

I Socrate è un sistema modulare di librerie in metallo caratterizzate dall'estrema flessibilità di composizione, adatto a soddisfare molteplici esigenze sia in termini di spazio che di stile. Il sistema Socrate è composto da una struttura base fatta di montanti, schienali e ripiani e da una serie molto ampia di originali accessori facilmente applicabili e intercambiabili. Il sistema Socrate è particolarmente adatto per biblioteche, librerie e book-shop.

EN Socrate is a modular metal shelving system whose remarkable flexibility enables it to meet all sorts of demands of space and style. The Socrate system combines uprights, panels and shelves to form a basic structure that can accommodate a very wide range of original accessories that are easy to attach and swap around. The Socrates system is particularly suitable for libraries and bookshops.

F Socrate est un système modulaire de bibliothèque avec une structure métallique caractérisée par la flexibilité extrême de sa composition, en mesure de répondre aux différentes exigences à la fois en termes d'espace et de style. Le système Socrate comprend une structure de base composée de montants, fonds et étagères et une gamme très vaste d'accessoires originaux, interchangeables et faciles à appliquer. Le système Socrates est particulièrement adapté aux bibliothèques, aux librairies et aux bouquinistes.

E Socrate es un sistema modular de librerías metálicas que se caracteriza por la libertad de composición, que logra atender a las múltiples necesidades tanto de espacio como de estilo. El sistema Socrate consta de una estructura básica de montantes, traseras y estantes, así como de un conjunto muy amplio de accesorios originales fácilmente ensamblables e intercambiables. El sistema Sócrates es especialmente adecuado para bibliotecas y librerías.

D Socrate ist ein modulares Regalsystem aus Metall, das sich durch extreme Flexibilität in der Zusammenstellung auszeichnet und den unterschiedlichsten Anforderungen in puncto Stil und Raumgestaltung genügen kann. Das System Socrate besteht aus einer Struktur mit Ständern, Rückenelementen und Regalböden sowie aus einer breit gefächerten Auswahl an originellen Zubehörelementen, die einfach angebracht und ausgetauscht werden können. Das Sokrates-System ist besonders für Bibliotheken, Buchhandlungen und Buchläden geeignet.

	MIN. 1 MAX. 3	MIN. 3 MAX. 6
H 238	MIN. 1 MAX. 2	MIN. 2 MAX. 5
H 200	MIN. 1 MAX. 2	MIN. 2 MAX. 4
H 162	MIN. 1 MAX. 1	MIN. 1 MAX. 2
H 86		

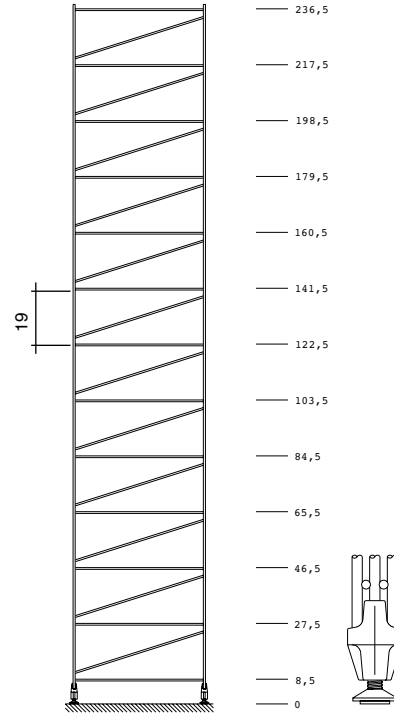



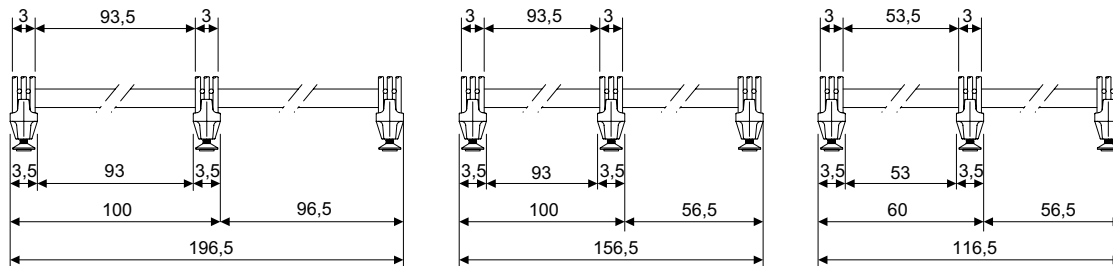
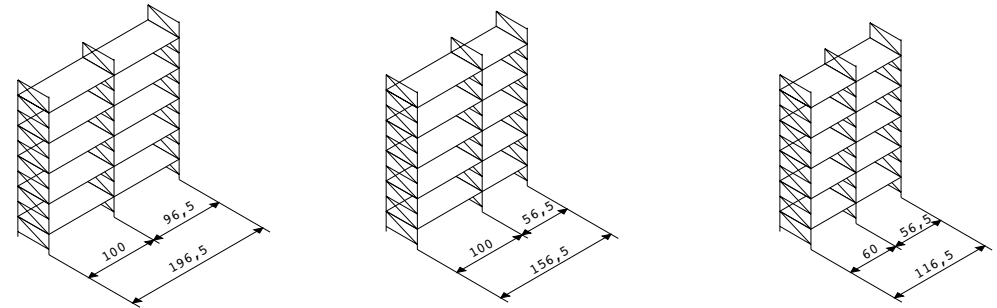



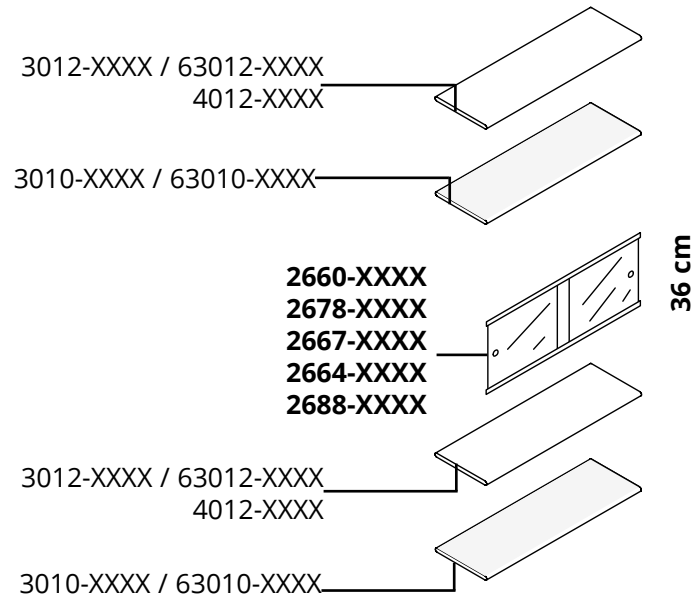





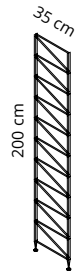





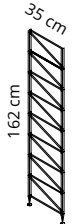

Numero minino e massimo di elementi per modulo completo.
 Minimum and maximum number of load bearing elements for a complete module.
 Nombre minimum et maximum d' éléments de soutien nécessaires pour un module complet.
 Numero maximo y minimo de elementos de carga para un modulo completo.
 Minimale und maximale Anzahl von benötigten Stabilisierungsteilen.





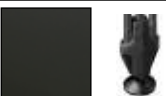





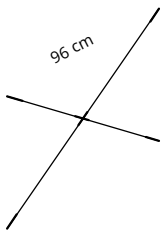

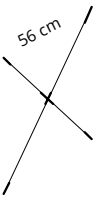

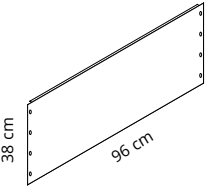

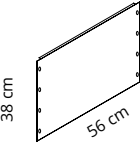













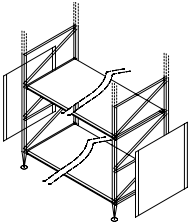
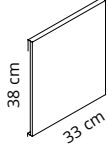

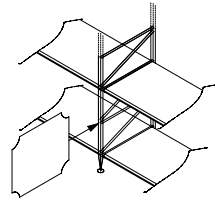
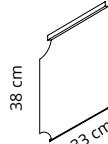









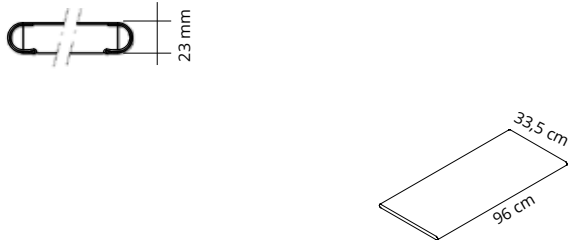
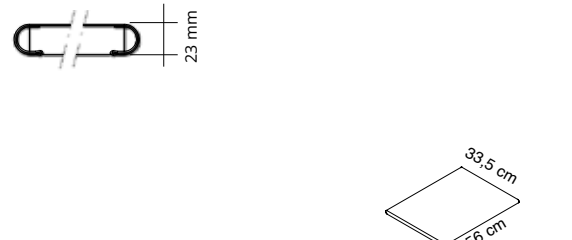



Dimensioni in cm - Dimensions in cm - Dimensions en cm - Dimensiones en cm - Dimensionen in cm

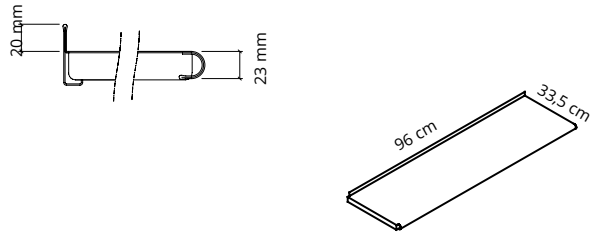
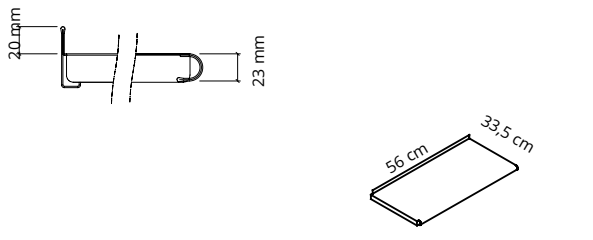









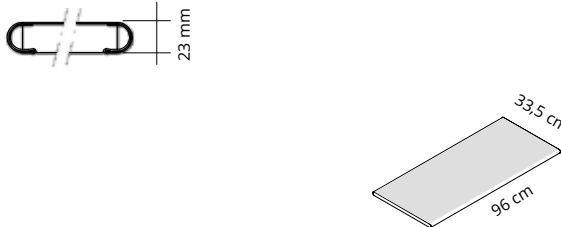
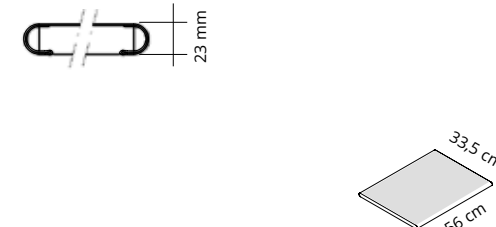





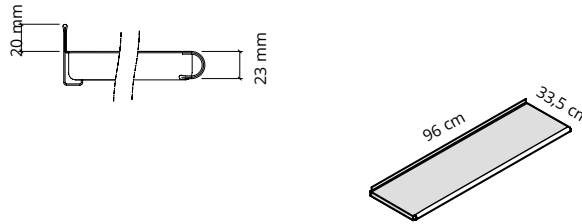
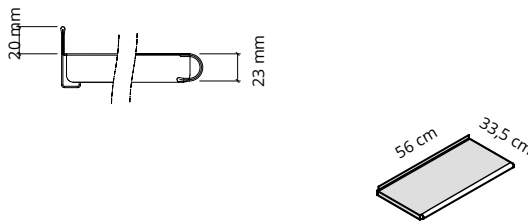









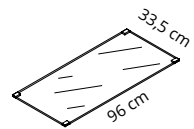
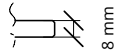
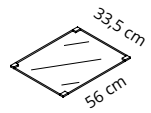





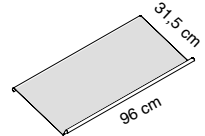

xxxx = variante colore - colour option - option couleur - variante color - Farbvariante

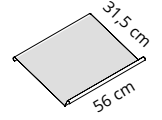
	 			 		
CD.	3400-BO	3400-GM	3400-N	3200-BO	3200-GM	3200-N
PR.	€ 168,00	€ 168,00	€ 168,00	€ 138,00	€ 138,00	€ 138,00
CL.	BO	GM	N	BO	GM	N
						
DS.	<p>Montanti in tondino di acciaio elettrosaldato verniciato con polveri epossidiche - Tappini e piedini inclusi. Powder-coated electrowelded steel rod side uprights - Feet and caps included. Montants en rond d'acier électrosoudé peint en époxy - Taquets et pieds inclus. Laterales en acero barnizado con polvos epoxídicos - Tapas y patas incluidas. Seitenteile aus elektrogelötetem Stahlrohr, mit Epoxypulver beschichtet. Abdeckkappen und FüÙe inklusive.</p>					
	 			 		
CD.	3600-BO	3600-GM	3600-N	3800-BO	3800-GM	3800-N
PR.	€ 134,00	€ 134,00	€ 134,00	€ 88,00	€ 88,00	€ 88,00
CL.	BO	GM	N	BO	GM	N
						
DS.	<p>Montanti in tondino di acciaio elettrosaldato verniciato con polveri epossidiche - Tappini e piedini inclusi. Powder-coated electrowelded steel rod side uprights - Feet and caps included. Montants en rond d'acier électrosoudé peint en époxy - Taquets et pieds inclus. Laterales en acero barnizado con polvos epoxídicos - Tapas y patas incluidas. Seitenteile aus elektrogelötetem Stahlrohr, mit Epoxypulver beschichtet. Abdeckkappen und FüÙe inklusive.</p>					

	 			 			 			 		
CD.	2910-BO	2910-GM	2910-N	2960-BO	2960-GM	2960-N	2712-BO	2712-GM	2712-N	2715-BO	2715-GM	2715-N
PR.	€ 45,00	€ 45,00	€ 45,00	€ 43,00	€ 43,00	€ 43,00	€ 87,00	€ 87,00	€ 87,00	€ 85,00	€ 85,00	€ 85,00
CL.	BO	GM	N	BO	GM	N	BO	GM	N	BO	GM	N
												
DS.	<p>Crociere in tondino di acciaio verniciato con polveri epossidiche. Powder-coated steel rod bracing crosses. Croisillons en rond d'acier peint en époxy. Soportes traseros en acero barnizado con polvos epoxídicos. Stabilisierungskreuze aus mit Epoxypulver beschichtetem Stahl.</p>						<p>Schienenl in lamiera verniciata. Powder-coated steel back panel. Panneaux postérieurs en acier peint. Traseras en acero barnizado. Rückwände aus pulverbeschichtetem Stahl.</p>					
	  			  								
CD.	2625-BO		2625-GM		2625-N		2738-BO		2738-GM		2738-N	
PR.	€ 78,00 (2 pcs)		€ 78,00 (2 pcs)		€ 78,00 (2 pcs)		€ 78,00 (2 pcs)		€ 78,00 (2 pcs)		€ 78,00 (2 pcs)	
CL.	BO		GM		N		BO		GM		N	
												
DS.	<p>Chiusure esterne in acciaio. Steel external closings. Fermetures externes en acier. Cierres externas en acero. Außenverkleidungen aus Stahl.</p>						<p>Chiusure interne in acciaio. Steel internal closing elements. Fermetures internes en acier. Cierres internas en acero. Innenverkleidungen aus Stahl.</p>					

						
CD.	3012-BO	3012-GM	3012-N	3062-BO	3062-GM	3062-N
PR.	€ 66,00	€ 66,00	€ 66,00	€ 65,00	€ 65,00	€ 65,00
CL.	BO	GM	N	BO	GM	N
						
DS.	<p>Ripiani in acciaio verniciato con polveri epossidiche, spessore 23 mm. Powder-coated steel shelves, 23mm thick. Tablettes en acier peint en époxy, épaisseur 23 mm. Estantes en acero barnizado con polvos epoxidicos, espesor 23 mm. Regalböden aus Epoxypulver beschichtetem Stahlblech, Stärke 23 mm.</p>					
						
CD.	63012-BO	63012-GM	63012-N	63062-BO	63062-GM	63062-N
PR.	€ 66,00	€ 66,00	€ 66,00	€ 65,00	€ 65,00	€ 65,00
CL.	BO	GM	N	BO	GM	N
						
DS.	<p>Ripiani in acciaio verniciato con polveri epossidiche. I ripiani possono essere montati dritti o inclinati. Powder-coated steel shelves. The shelves can be assembled straight or inclined. Tablettes en acier peint en époxy. Les tablettes peuvent être montées soit à plat ou inclinées. Estantes en acero barnizado con polvos epoxidicos. Los estantes se pueden colocar rectos o inclinados. Regalböden aus Epoxypulver beschichtetem Stahlblech. Die Regalböden können schräg oder gerade montiert werden.</p>			<p>Dettaglio reggilibri OPZIONALE Detail of book holder OPTIONAL vedi pag. / see page 23</p> 		

						
CD.	3010-BO	3010-GM	3010-N	3060-BO	3060-GM	3060-N
PR.	€ 84,00	€ 84,00	€ 84,00	€ 76,00	€ 76,00	€ 76,00
CL.	BO	GM	N	BO	GM	N
						
DS.	<p>Ripiani in acciaio microforato verniciato con polveri epossidiche, spessore 23 mm. Powder-coated micro-perforated steel shelves, 23mm thick. Tablettes en acier microperforé peint en époxy, épaisseur 23 mm. Estantes en acero microperforado barnizado con polvos epoxidicos, espesor 23 mm. Regalböden aus gelochtem, mit Epoxypulver beschichtetem Stahlblech, Stärke 23 mm.</p>					
						
CD.	63010-BO	63010-GM	63010-N	63060-BO	63060-GM	63060-N
PR.	€ 84,00	€ 84,00	€ 84,00	€ 76,00	€ 76,00	€ 76,00
CL.	BO	GM	N	BO	GM	N
						
DS.	<p>Ripiani in acciaio microforato verniciato con polveri epossidiche. I ripiani possono essere montati dritti o inclinati. Powder-coated micro-perforated steel shelves. The shelves can be assembled straight or inclined. Tablettes en acier microperforé peint en époxy. Les tablettes peuvent être montées soit à plat ou inclinées. Estantes en acero microperforado barnizado con polvos epoxidicos. Los estantes se pueden colocar rectos o inclinados. Regalböden aus gelochtem, mit Epoxypulver beschichtetem Stahlblech. Die Regalböden können schräg oder gerade montiert werden.</p>			<p>Dettaglio reggilibri OPZIONALE Detail of book holder OPTIONAL vedi pag. / see page 23</p> 		

	 8 mm  33,5 cm 96 cm			 8 mm  33,5 cm 56 cm		
CD.	3014-N	3014-GR	3014-BO	3064-N	3064-GR	3064-BO
PR.	€ 98,00	€ 98,00	€ 98,00	€ 89,00	€ 89,00	€ 89,00
CL.						
						
DS.	Ripiani in vetro temperato trasparente spessore 8 mm, supporti in tecnopolimero nero, grigio o bianco. Transparent tempered glass shelves, 8 mm thick. Black, grey or white supports. Tablettes en verre trempé transparent épaisseur 8 mm, supports noirs, gris ou blancs. Estantes en cristal templado transparente espesor 8 mm, soportes negros, gris o blancos. Regalböden aus gehärtetem Sicherheitsglas transparent, Stärke 8 mm, schwarze, graue oder weiße Halterungen.					
	 40 mm  31,5 cm 96 cm 			 40 mm  31,5 cm 56 cm 		
CD.	3910-BO	3910-GM	3910-N	3960-BO	3960-GM	3960-N
PR.	€ 97,00	€ 97,00	€ 97,00	€ 84,00	€ 84,00	€ 84,00
CL.	BO	GM	N	BO	GM	N
						
DS.	Ripiani espositori inclinati in acciaio microforato verniciato con polveri epossidiche. Inclined display shelves in powder-coated micro-perforated steel. Tablettes/présentoirs inclinés en acier microperforé peint en époxy. Estantes expositorios inclinados en acero microperforado barnizado con polvos epoxidicos. Schrägablare aus gelochtem, mit Epoxypulver beschichtetem Stahl					

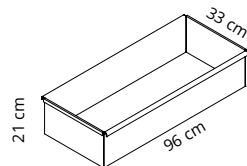

Da ordinare a multipli di 10 pezzi.
To be ordered in multiples of 10 pieces.
A commander par multiple de 10 pièces.
A pedirse en múltiplos de 10 piezas.
Verpackungseinheit 10 Stück.

Per art.:
For ref.:
Pour réf.:
Para ref.:
Für Art.:
63010, 63060
63012, 63062



CD.	3510-BO	3510-GM	3510-N	6A2780
PR.	€ 238,00	€ 238,00	€ 238,00	€ 14,50 cad each
CL.	BO	GM	N	C
DS.	Contenitore in acciaio verniciato. Case in powder-coated steel. Bac en acier peint. Recipiente en acero barnizado. Behälter aus pulverbeschichtetem Stahl.			Reggilibro in acciaio cromato. Chrome-plated steel book holder. Serre-livres en acier chromé. Separadores en acero cromado. Buchstütze aus verchromtem Stahl.

Solo per ripiani art:
Only for shelves code:
Seulement pour tablettes réf:
Solo para estantes ref:
Nur für Regalböden Art:
3010, 3012, 63010, 63012

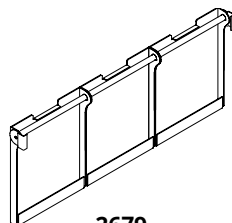







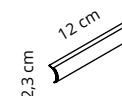



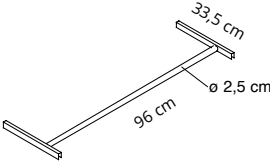

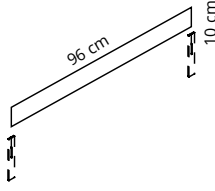

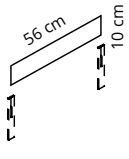







2679
€ 267,00

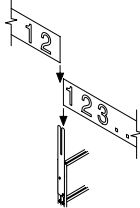

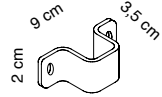







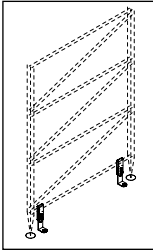

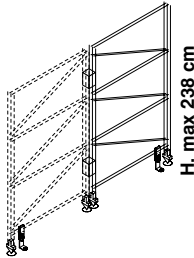











Per ripiani art:
For shelves code:
Pour tablettes réf:
Para estantes ref:
Für Regalböden Art:
3010, 3060, 3012, 3062,
3910, 3960
63010, 63060, 63012, 63062

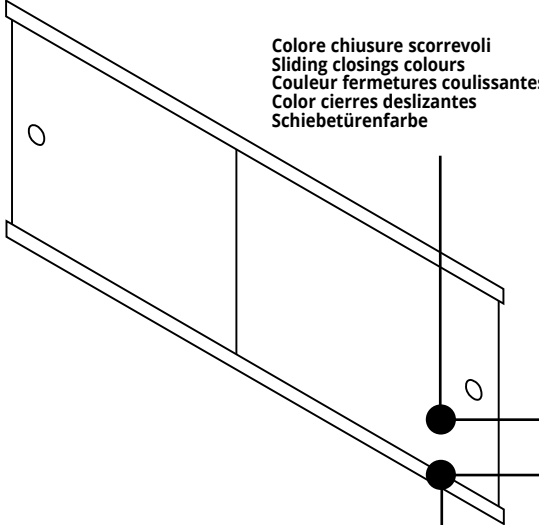
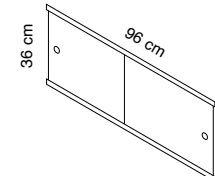

CD.	2746-BO	2746-GM	2746-N	6A52
PR.	€ 17,00	€ 17,00	€ 17,00	€ 54,00 (10 pcs)
CL.	BO	GM	N	T
DS.	Bandiera segnaletica in acciaio verniciato. Powder-coated steel sign banner. Bande signalétique en acier peint. Placa de señalización en acero barnizado. Beschriftungsschild aus pulverbeschichtetem Stahl.			Segnaletica per ripiani con bordo tondo. Sign system for round edge shelves. Signalisation pour tablettes avec bord rond. Señalización para estantes borde redondo. Beschilderung für Tablare mit abgerundeter Kante.

 	 	 						
<p>CD. 2812-BO</p>	<p>CD. 2812-GM</p>	<p>CD. 2812-N</p>	<p>CD. 6A2272 (BO)</p>	<p>CD. 6A2272 (GM)</p>	<p>CD. 6A2272 (N)</p>	<p>CD. 6A2274 (BO)</p>	<p>CD. 6A2274 (GM)</p>	<p>CD. 6A2274 (N)</p>
<p>PR. € 96,00</p>	<p>PR. € 96,00</p>	<p>PR. € 96,00</p>	<p>PR. € 55,00</p>	<p>PR. € 55,00</p>	<p>PR. € 55,00</p>	<p>PR. € 48,00</p>	<p>PR. € 48,00</p>	<p>PR. € 48,00</p>
<p>CL. BO</p>	<p>CL. GM</p>	<p>CL. N</p>	<p>CL. BO</p>	<p>CL. GM</p>	<p>CL. N</p>	<p>CL. BO</p>	<p>CL. GM</p>	<p>CL. N</p>
								
<p>DS. Portabiti/poggiapiedi in acciaio verniciato e tubo cromato. Profondità regolabile. Powder-coated steel clothes-hangers/foot-rest and chrome-plated rod. Adjustable depth. Portemanteaux/repose-pieds en acier peint et tige en acier chromé. Réglable en profondeur. Perchero/reposapiés en acero barnizado y barra en acero cromado. Regulable en profundidad. Garderobenstange/Fußstütze aus beschichtetem Stahl und Stange aus verchromtem Stahl. Verstellbarer Tiefe.</p>			<p>DS. Fascioni segnaletici in acciaio verniciato. Powder-coated steel sign bands. Panneaux signalétiques en acier peint. Bandas de señalización en acero barnizado. Beschriftungspaneele aus pulverbeschichtetem Stahl.</p>					
<p>Per art.: For ref.: Pour réf.: Para ref.: Für Art.: 6A2272, 6A2274</p>  								
<p>CD. 6A2278 (BO)</p>	<p>CD. 6A2278 (GM)</p>	<p>CD. 6A2278 (N)</p>	<p>CD. 4994-GM</p>			<p>CD. 4994-BO</p>		
<p>PR. € 29,00 (2 pcs)</p>	<p>PR. € 29,00 (2 pcs)</p>	<p>PR. € 29,00 (2 pcs)</p>	<p>PR. € 22,00</p>			<p>PR. € 22,00</p>		
<p>CL. BO</p>	<p>CL. GM</p>	<p>CL. N</p>	<p>CL. GM</p>			<p>CL. BO</p>		
								
<p>DS. Supporti fascione segnaletico. Supports for sign bands. Supports pour panneaux signalétiques. Soportes para bandas de señalización. Halierung für Beschriftungspaneele.</p>			<p>DS. Staffa per fissaggio a parete dei montanti. Steel bracket used to fix side upright to wall. Etrier de fixation au mur pour montants. Fijación a pared para laterales. Klammer für Wandbefestigung der Seitenteile.</p>					

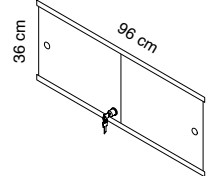
	  			 		
CD.	2646-BO	2646-GM	2646-N	2995/46-BO	2995/46-GM	2995/46-N
PR.	€ 38,00	€ 38,00	€ 38,00	€ 45,00	€ 45,00	€ 45,00
CL.	BO	GM	N	BO	GM	N
						
DS.	<p>Coppia staffe per fissaggio a terra dei montanti. Da utilizzare in caso di moduli non fissati a parete. Couple of brackets for side uprights fixing to the floor. To be used only for modules not attached to the wall. Paire d'étriers de fixation au sol pour montants. A utiliser pour modules qui ne sont pas fixés au mur. 2 fijación al suelo para laterales. Para ser usados solamente en el caso de los módulos no fijados a la pared. Ein Paar Halterungen zur Befestigung der Seitensteher am Boden. Nur zur Verwendung bei Elementen, welche nicht an der Wand befestigt werden.</p>			<p>2 giunti trasparenti per unione bifronte e 2 staffe per fissaggio a terra dei montanti. 2 transparent joints for double-sided connection + 2 brackets to fix uprights to the floor. 2 joints transparents pour accouplement bifrontal et 2 etrier fixation au sol pour montants. 2 juntas transparentes para conexión bifrontal y 2 fijación al suelo para laterales. 2 Doppelseitige Module und 2 Klammer zur Bodenbefestigung von Seitenteilen.</p>		
	 <p>90°</p>  			<p>Per art. / For ref. / Pour réf. / Para ref. / Für Art. 3010, 3012, 63010, 63012 ATTENZIONE: 1 3973-GM per/for 1 code 3010, 3012 1 3973-GM per/for 2 code 63010, 63012</p> 		<p>Per art. / For ref. / Pour réf. / Para ref. / Für Art. 3060, 3062, 63060, 63062 ATTENZIONE: 1 3974-GM per/for 1 code 3060, 3062 1 3974-GM per/for 2 code 63060, 63062</p> 
CD.		2996-GM		3973-GM		3974-GM
PR.		€ 19,00		€ 39,00		€ 38,00
CL.		GM		GM		GM
						
DS.		<p>Coppia di squadrette per unione montanti a 90°. Pair of joints for 90° side uprights connection. Paire de joints pour union montants à 90°. Par de juntas para conexión de laterales a 90°. 2 Beschläge für Seitenteilekombinationen 90°.</p>		<p>2 rinforzi in acciaio verniciato per ripiani Top posizionati ad altezza 100 cm o inferiore. 2 strengthenings for top shelves on units 100 cm high or lower. 2 renforcements tablette dessus, pour modules en hauteur 100 cm ou inférieure. 2 refuerzos para estante superior situado a una altura de 100 cm o inferior. 2 Verstärkung für oberen Regalböden bei einer Regalhöhe von 100 cm oder niedriger.</p>		

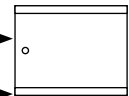
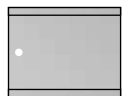
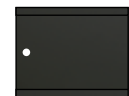
 <p>Colore chiusure scorrevoli Sliding closings colours Couleur fermetures coulissantes Color cierres deslizantes Schiebetürenfarbe</p> <p>Colore guide Slides colours Couleur glissières Color guías Schienenfarbe</p>	<p>Per piano superiore in metallo (vedi pag.17) For steel upper shelf (see page 17) Pour tablette supérieure en acier (voir page 17) Para estante superior en acero (ver pag. 17) Wenn oberes Tablar aus Stahl (Seite 17)</p>		
<p>Per piano superiore in metallo (vedi pag.17) For steel upper shelf (see page 17) Pour tablette supérieure en acier (voir page 17) Para estante superior en acero (ver pag. 17) Wenn oberes Tablar aus Stahl (Seite 17)</p> 	<p>Per piano superiore in metallo (vedi pag.17) For steel upper shelf (see page 17) Pour tablette supérieure en acier (voir page 17) Para estante superior en acero (ver pag. 17) Wenn oberes Tablar aus Stahl (Seite 17)</p>		 
<p>CD.</p> <p>PR.</p> <p>CL.</p>	<p>2660-BOBO € 108,00</p> 	<p>2660-GMGM € 108,00</p> 	<p>2660-NN € 108,00</p> 
<p>DS.</p> <p>Chiusure scorrevoli in acciaio verniciato, guide in acciaio verniciato grigio metallizzato, bianco opaco o nero. Powder-coated steel sliding closings, slides in metal grey, mat white or black powder-coated steel. Fermetures coulissantes en acier peint, glissières en acier peint gris métallisé, blanc mat ou noir. Cierres deslizantes en acero barnizado, guías de acero barnizado gris metalizado, blanco mate o negro. Schiebetüren aus pulverbeschichtetem Stahl, Schienen aus grau metallic, mattweiß oder schwarz pulverbeschichtetem Stahl.</p> <p>Con serratura - With lock - Avec serrure - Con cerradura - Mit Schloss.</p>			

Per piano superiore in metallo (vedi pag.17)
 For steel upper shelf (see page 17)
 Pour tablette supérieure en acier (voir page 17)
 Para estante superior en acero (ver pag. 17)
 Wenn oberes Tablar aus Stahl (Seite 17)

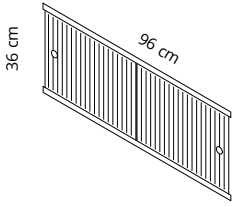

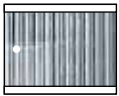
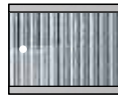
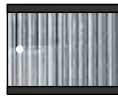
CD.	2688-BO	2688-GM	2688-N
PR.	€ 168,00	€ 168,00	€ 168,00
CL.			
DS.	Chiusure scorrevoli in vetro cannettato, guide in acciaio verniciato grigio metallizzato, bianco opaco o nero. Ribbed glass sliding closings, slides in metal grey, mat white or black powder-coated steel. Fermetures coulissantes en verre cannelé, glissières en acier peint gris métallisé, blanc mat ou noir. Cierres deslizantes en cristal acanalado, guías de acero barnizado gris metalizado, blanco mate o negro. Schiebetüren aus mit geripptem Glas, Schienen aus grau metallic, mattweiß oder schwarz pulverbeschichtetem Stahl.		



Per piano superiore in metallo (vedi pag.17)
 For steel upper shelf (see page 17)
 Pour tablette supérieure en acier (voir page 17)
 Para estante superior en acero (ver pag. 17)
 Wenn oberes Tablar aus Stahl (Seite 17)



CD.	2660-LBO	2660-LGM	2660-LN
PR.	€ 248,00	€ 248,00	€ 248,00
CL.			
DS.	Chiusure scorrevoli in MDF placcato alluminio impiallacciato legno Noce Canaletto, da un lato, e Rovere, dall'altro lato. Guide in acciaio verniciato grigio metallizzato, bianco opaco o nero. Closing slides in MDF, aluminum plated that are walnut veneered on one side and oak veneered on the other. Slides in metal grey, mat white or black powder-coated steel. Fermetures coulissantes en MDF plaqué aluminium et contre-plaqué en noyer Canaletto d'une coté et rouvre de l'autre. Glissières en acier peint gris métallisé, blanc mat ou noir. Cierres deslizantes en MDF, aluminio plateado que en un lado es nogal y en el otro lado es roble. Guías de acero barnizado gris metalizado, blanco mate o negro. Schiebetüren aus mit Aluminium verkleidetem MDF mit Walnussfurnier auf der einen und Eichenfurnier auf der anderen Seite. Schiebetüren aus metallgrau, mattweiß oder schwarz pulverbeschichtetem Stahl.		



1



2





3



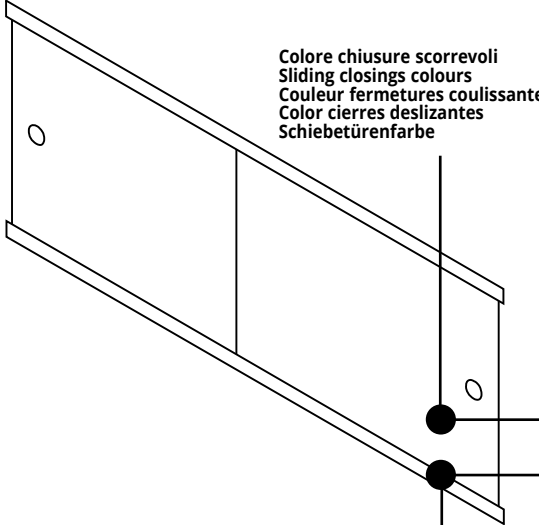
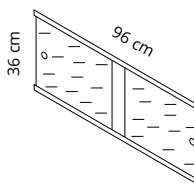
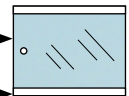
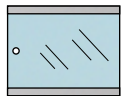
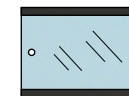
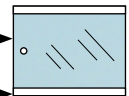
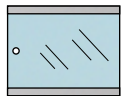
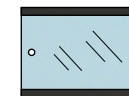
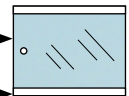
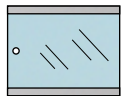
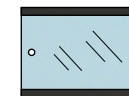
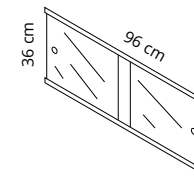
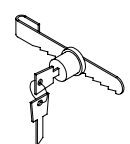
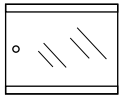
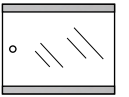
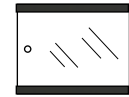
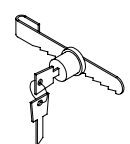
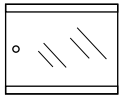
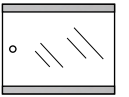
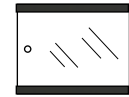
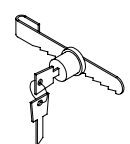
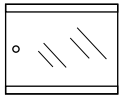
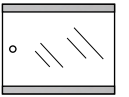
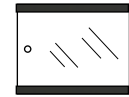

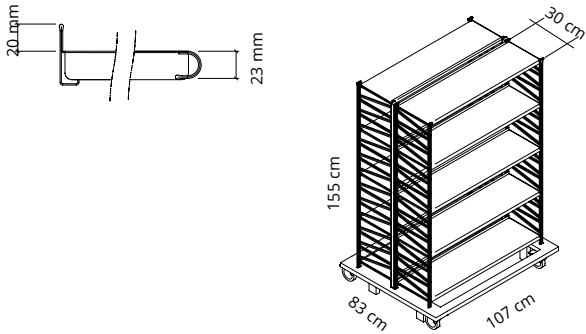
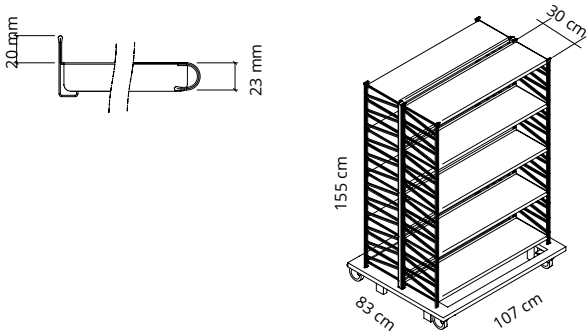

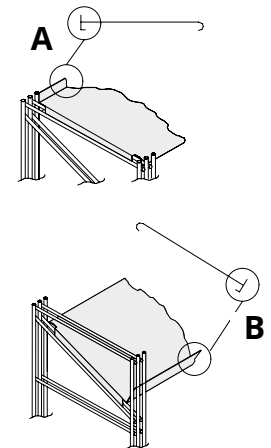

4











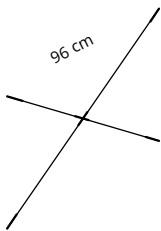

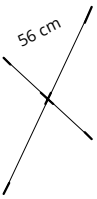

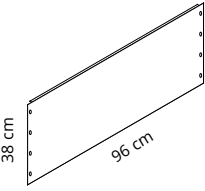

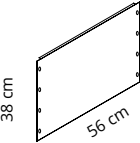

 <p>Colore chiusure scorrevoli Sliding closings colours Couleur fermetures coulissantes Color cierres deslizantes Schiebetürenfarbe</p> <p>Colore guide Slides colours Couleur glissières Color guías Schienenfarbe</p>	<p>Per piano superiore in metallo (vedi pag.17) For steel upper shelf (see page 17) Pour tablette supérieure en acier (voir page 17) Para estante superior en acero (ver pag. 17) Wenn oberes Tablar aus Stahl (Seite 17)</p>  <table border="1" data-bbox="728 462 2067 654"> <tr> <td>CD.</td> <td>2667-BO</td> <td>2667-GM</td> <td>2667-N</td> </tr> <tr> <td>PR.</td> <td>€ 158,00</td> <td>€ 158,00</td> <td>€ 158,00</td> </tr> <tr> <td>CL.</td> <td></td> <td></td> <td></td> </tr> </table> <p>DS.</p> <p>Chiusure scorrevoli in vetro satinato/acidato, guide in acciaio verniciato grigio metallizzato, bianco opaco o nero. Satin glass sliding closings, slides in metal grey, mat white or black powder-coated steel. Fermetures coulissantes en verre satiné, glissières en acier peint gris métallisé, blanc mat ou noir Cierres deslizantes en cristal satinado, guías en acero barnizado gris metalizado, blanco mate o negro. Schiebetüren aus satiniertem Glas, Schienen aus grau metallic, mattweiß oder schwarz pulverbeschichtetem Stahl.</p>			CD.	2667-BO	2667-GM	2667-N	PR.	€ 158,00	€ 158,00	€ 158,00	CL.						
CD.	2667-BO	2667-GM	2667-N															
PR.	€ 158,00	€ 158,00	€ 158,00															
CL.																		
<p>Per piano superiore in metallo (vedi pag.17) For steel upper shelf (see page 17) Pour tablette supérieure en acier (voir page 17) Para estante superior en acero (ver pag. 17) Wenn oberes Tablar aus Stahl (Seite 17)</p> 	<table border="1" data-bbox="728 1165 2067 1356"> <tr> <td>CD.</td> <td>2664-BO</td> <td>2664-GM</td> <td>2664-N</td> <td rowspan="3"></td> </tr> <tr> <td>PR.</td> <td>€ 137,00</td> <td>€ 137,00</td> <td>€ 137,00</td> <td>2659</td> </tr> <tr> <td>CL.</td> <td></td> <td></td> <td></td> <td>€ 22,00</td> </tr> </table> <p>DS.</p> <p>Chiusure scorrevoli in vetro trasparente, guide in acciaio verniciato grigio metallizzato, bianco opaco o nero. Transparent glass sliding closings, slides in metal grey, mat white or black powder-coated steel. Fermetures coulissantes en verre transparent, glissières en acier peint gris métallisé, blanc mat ou noir. Cierres deslizantes en cristal transparente, guías de acero barnizado gris metalizado, blanco mate o negro. Schiebetüren aus transparentem Glas, Schienen aus grau metallic, mattweiß oder schwarz pulverbeschichtetem Stahl.</p> <p>Serratura per chiusure in vetro per: Lock for glass closing for: Serrure pour fermetures en verre pour: Cerradura para cierre en cristal para: Schloss für Glasschiebetüren für: art. 2664-BO / 2664-GM / 2664-N</p>			CD.	2664-BO	2664-GM	2664-N		PR.	€ 137,00	€ 137,00	€ 137,00	2659	CL.				€ 22,00
CD.	2664-BO	2664-GM	2664-N															
PR.	€ 137,00	€ 137,00	€ 137,00		2659													
CL.					€ 22,00													

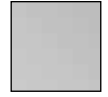
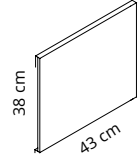
 <p>6A2102 (GM)</p>	 <p>6A2100 (GM)</p>
<p>PR. € 2.178,00</p>	<p>PR. € 2.350,00</p>
<p>CL. GM</p> 	<p>CL. GM</p> 
<p>DS. Libreria/espositore bifronte su ruote con 10 ripiani in acciaio pieno. I ripiani possono essere montati dritti o inclinati. Double-sided shelving/display unit on castors, with 10 plain steel shelves. The shelves can be assembled straight or inclined. Rayonnage/présentoir double-face sur roulettes, avec 10 tablettes en acier plein. Les tablettes peuvent être montées soit à plat ou inclinées. Libreria/expositor a dos caras con ruedas y 10 estantes en acero sólido. Los estantes se pueden colocar rectos o inclinados. Doppelseitiges Regal/Aussteller auf Rollen mit 10 Regalböden aus Stahlblech. Die Regalböden können schräg oder gerade montiert werden.</p>	<p>DS. Libreria/espositore bifronte su ruote con 10 ripiani in acciaio microforato. I ripiani possono essere montati dritti o inclinati. Double-sided shelving/display unit on castors, with 10 micro-perforated steel shelves. The shelves can be assembled straight or inclined. Rayonnage/présentoir double-face sur roulettes, avec 10 tablettes en acier microperforé. Les tablettes peuvent être montées soit à plat ou inclinées. Libreria/expositor a dos caras con ruedas y 10 estantes en acero microperforado. Los estantes se pueden colocar rectos o inclinados. Doppelseitiges Regal/Aussteller auf Rollen mit 10 Regalböden aus gelochtem Stahlblech. Die Regalböden können schräg oder gerade montiert werden.</p>

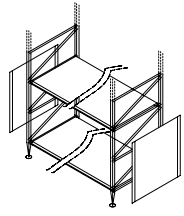
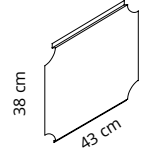

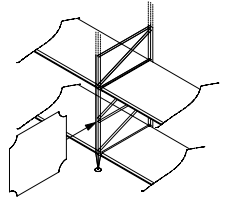
I ripiani possono essere montati dritti o inclinati.
 The shelves can be assembled straight or inclined.
 Les tablettes peuvent être montées soit à plat ou inclinées.
 Los estantes se pueden colocar rectos o inclinados.
 Die Regalböden können schräg oder gerade montiert werden.

				
CD.	4200-BO		4200-GM	
PR.	€ 147,00		€ 147,00	
CL.	BO		GM	
				
DS.	<p>Montanti in tondino di acciaio elettrosaldato verniciato con polveri epossidiche - Tappini e piedini inclusi. Powder-coated electrowelded steel rod side uprights - Feet and caps included. Montants en rond d'acier électrosoudé peint en époxy - Taquets et pieds inclus. Laterales en acero barnizado con polvos epoxídicos - Tapas y patas incluidas. Seitenteile aus elektrogelötetem Stahlrohr, mit Epoxypulver beschichtet. Abdeckkappen und FüÙe inklusive.</p>			
				
CD.	4800-BO		4800-GM	
PR.	€ 92,00		€ 92,00	
CL.	BO		GM	
				
DS.	<p>Montanti in tondino di acciaio elettrosaldato verniciato con polveri epossidiche - Tappini e piedini inclusi. Powder-coated electrowelded steel rod side uprights - Feet and caps included. Montants en rond d'acier électrosoudé peint en époxy - Taquets et pieds inclus. Laterales en acero barnizado con polvos epoxídicos - Tapas y patas incluidas. Seitenteile aus elektrogelötetem Stahlrohr, mit Epoxypulver beschichtet. Abdeckkappen und FüÙe inklusive.</p>			

	 		 		 		 	
CD.	2910-BO		2910-GM		2960-BO		2960-GM	
PR.	€ 45,00		€ 45,00		€ 43,00		€ 43,00	
CL.	BO		GM		BO		GM	
								
DS.	<p>Crociere in tondino di acciaio verniciato con polveri epossidiche. Powder-coated steel rod bracing crosses. Croisillons en rond d'acier peint en époxy. Soportes traseros en acero barnizado con polvos epoxídicos. Stabilisierungskreuze aus mit Epoxypulver beschichtetem Stahl.</p>				<p>Schienali in lamiera verniciata. Powder-coated steel back panel. Panneaux postérieurs en acier peint. Traseras en acero barnizado. Rückwände aus pulverbeschichtetem Stahl.</p>			
	  				  			
CD.	2612-BO		2612-GM		2735-BO		2735-GM	
PR.	€ 79,00 (2 pcs)		€ 79,00 (2 pcs)		€ 79,00 (2 pcs)		€ 79,00 (2 pcs)	
CL.	BO		GM		BO		GM	
								
DS.	<p>Chiusure esterne in acciaio. Steel external closings. Fermetures externes en acier. Cierres externas en acero. Außenverkleidungen aus Stahl.</p>				<p>Chiusure interne in acciaio. Steel internal closing elements. Fermetures internes en acier. Cierres internas en acero. Innenverkleidungen aus Stahl.</p>			

CD.	4012-GM	4012-BO	4062-GM	4062-BO
PR.	€ 74,00	€ 74,00	€ 64,00	€ 64,00
CL.	GM	BO	GM	BO
DS.	<p>Ripiani in acciaio verniciato con polveri epossidiche, spessore 23 mm. Powder-coated steel shelves, 23mm thick. Tablettes en acier peint en époxy, épaisseur 23 mm. Estantes en acero barnizado con polvos epoxidicos, espesor 23 mm. Regalböden aus Epoxypulver beschichtetem Stahlblech, Stärke 23 mm.</p>			
CD.	4014-GR	4014-BO	4064-GR	4064-BO
PR.	€ 108,00	€ 108,00	€ 98,00	€ 98,00
CL.				
DS.	<p>Ripiani in vetro temperato trasparente spessore 8 mm, supporti in tecnopolimero nero, grigio o bianco. Transparent tempered glass shelves, 8 mm thick. Black, grey or white supports. Tablettes en verre trempé transparent épaisseur 8 mm, supports noirs, gris ou blancs. Estantes en cristal templado transparente espesor 8 mm, soportes negros, gris o blancos. Regalböden aus gehärtetem Sicherheitsglas transparent, Stärke 8 mm, schwarze, graue oder weiße Halterungen.</p>			

Colore chiusure scorrevoli
Sliding closings colours
Couleur fermetures coulissantes
Color cierres deslizantes
Schiebetürenfarbe

Colore guide
Slides colours
Couleur glissières
Color guías
Schienenfarbe





Per piano superiore in metallo (vedi pag.17)
For steel upper shelf (see page 17)
Pour tablette supérieure en acier (voir page 17)
Para estante superior en acero (ver pag. 17)
Wenn oberes Tablar aus Stahl (Seite 17)

CD.	2688-GM	2688-BO
PR.	€ 168,00	€ 168,00
CL.		
DS.	<p>Chiusure scorrevoli in vetro cannettato, guide in acciaio verniciato grigio metallizzato o bianco opaco. Ribbed glass sliding closings, slides in metal grey or mat white powder-coated steel. Fermetures coulissantes en verre cannelé, glissières en acier peint gris métallisé ou blanc mat. Cierres deslizantes en cristal acanalado, guías de acero barnizado gris metalizado o blanco mate. Schiebetüren aus mit geripptem Glas, Schienen aus grau metallic oder mattweiß pulverbeschichtetem Stahl.</p>	

Per piano superiore in metallo (vedi pag.17)
For steel upper shelf (see page 17)
Pour tablette supérieure en acier (voir page 17)
Para estante superior en acero (ver pag. 17)
Wenn oberes Tablar aus Stahl (Seite 17)

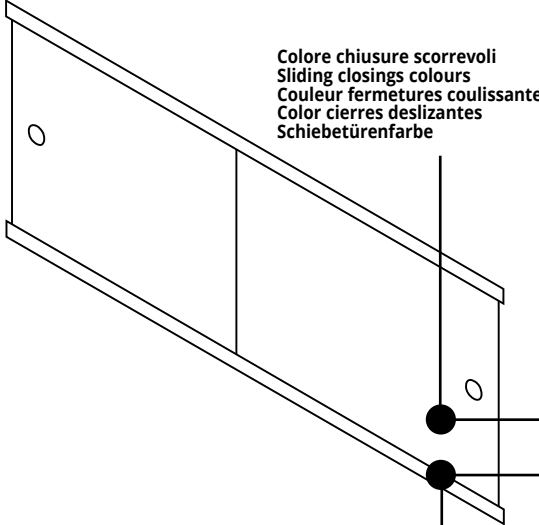
CD.	2660-LGM	2660-LBO
PR.	€ 248,00	€ 248,00
CL.		
DS.	<p>Chiusure scorrevoli in MDF placcato alluminio impiallacciato legno Noce Canaletto, da un lato, e Rovere, dall'altro lato. Guide in acciaio verniciato grigio metallizzato o bianco opaco. Closing slides in MDF, aluminum plated that are walnut veneered on one side and oak veneered on the other. Slides in metal grey or mat white powder-coated steel. Fermetures coulissantes en MDF plaqué aluminium et contre-plaqué en noyer Canaletto d'une coté et rouvre de l'autre. Glissières en acier peint gris métallisé ou blanc mat. Cierres deslizantes en MDF, aluminio plateado que en un lado es nogal y en el otro lado es roble. Guías de acero barnizado gris metalizado o blanco mate. Schiebetüren aus mit Aluminium verkleidetem MDF mit Walnussfurnier auf der einen und Eichenfurnier auf der anderen Seite. Schiebetüren aus metallgrau oder mattweiß pulverbeschichtetem Stahl.</p>	

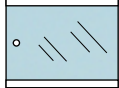
- 1.
- 2.
- 3.
- 4.

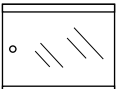
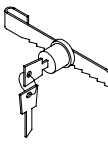
 <p>Colore chiusure scorrevoli Sliding closings colours Couleur fermetures coulissantes Color cierres deslizantes Schiebetürenfarbe</p> <p>Colore guide Slides colours Couleur glissières Color guías Schienenfarbe</p>	<p>Per piano superiore in metallo (vedi pag.17) For steel upper shelf (see page 17) Pour tablette supérieure en acier (voir page 17) Para estante superior en acero (ver pag. 17) Wenn oberes Tablar aus Stahl (Seite 17)</p> <p>CD. 2667-GM PR. € 158,00 CL. </p> <p>DS. Chiusure scorrevoli in vetro satinato/acidato, guide in acciaio verniciato grigio metallizzato o bianco opaco. Satin glass sliding closings, slides in metal grey or mat white powder-coated steel. Fermetures coulissantes en verre satiné, glissières en acier peint gris métalisé ou blanc mat. Cierres deslizantes en cristal satinado, guías en acero barnizado gris metalizado o blanco mate. Schiebetüren aus satiniertem Glas, Schienen aus grau metallic oder mattweiß pulverbeschichtetem Stahl.</p>	<p>36 cm 96 cm</p> <p>2667-BO € 158,00</p> <p></p>
<p>Per piano superiore in metallo (vedi pag.17) For steel upper shelf (see page 17) Pour tablette supérieure en acier (voir page 17) Para estante superior en acero (ver pag. 17) Wenn oberes Tablar aus Stahl (Seite 17)</p> <p>CD. 2664-GM PR. € 137,00 CL. </p> <p>DS. Chiusure scorrevoli in vetro trasparente, guide in acciaio verniciato grigio metallizzato o bianco opaco. Transparent glass sliding closings, slides in metal grey or mat white powder-coated steel. Fermetures coulissantes en verre transparent, glissières en acier peint gris métalisé ou blanc mat. Cierres deslizantes en cristal transparente, guías de acero barnizado gris metalizado o blanco mate. Schiebetüren aus transparentem Glas, Schienen aus grau metallic oder mattweiß pulverbeschichtetem Stahl.</p>	<p>36 cm 96 cm</p> <p>2664-BO € 137,00</p> <p></p>	<p></p> <p>2659 € 22,00</p> <p>Serratura per chiusure in vetro per: Lock for glass closing for: Serrure pour fermetures en verre pour: Cerradura para cierre en cristal para: Schloss für Glasschiebetüren für: art. 2664-BO / 2664-GM</p>

Per piano superiore in metallo (vedi pag.17)
For steel upper shelf (see page 17)
Pour tablette supérieure en acier (voir page 17)
Para estante superior en acero (ver pag. 17)
Wenn oberes Tablar aus Stahl (Seite 17)

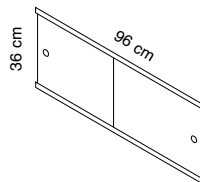





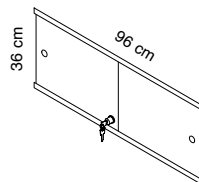

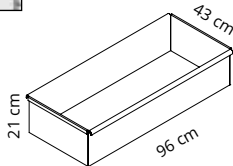

CD.	2660-GMGM	2660-BOBO
PR.	€ 108,00	€ 108,00
CL.		
DS.	<p>Chiusure scorrevoli in acciaio verniciato, guide in acciaio verniciato grigio metallizzato o bianco opaco. Powder-coated steel sliding closings, slides in metal grey or mat white powder-coated steel. Fermetures coulissantes en acier peint, glissières en acier peint gris métalisé ou blanc mat. Cierres deslizantes en acero barnizado, guías de acero barnizado gris metalizado o blanco mate. Schiebetüren aus pulverbeschichtetem Stahl, Schienen aus grau metallic oder mattweiß pulverbeschichtetem Stahl.</p>	

Per piano superiore in metallo (vedi pag.17)
For steel upper shelf (see page 17)
Pour tablette supérieure en acier (voir page 17)
Para estante superior en acero (ver pag. 17)
Wenn oberes Tablar aus Stahl (Seite 17)

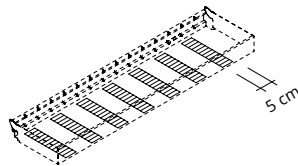





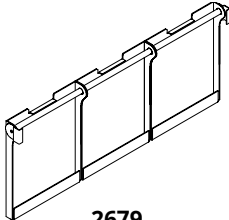



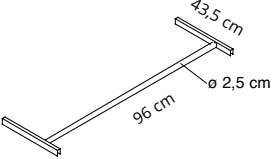





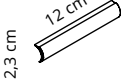





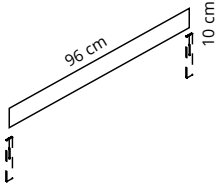

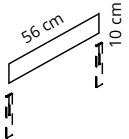
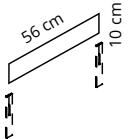

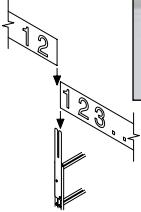
CD.	2678-GMGM	2678-BOBO
PR.	€ 168,00	€ 168,00
CL.		
DS.	<p>Chiusure scorrevoli in acciaio verniciato, guide in acciaio verniciato grigio metallizzato o bianco opaco. Powder-coated steel sliding closings, slides in metal grey or mat white powder-coated steel. Fermetures coulissantes en acier peint, glissières en acier peint gris métalisé ou blanc mat. Cierres deslizantes en acero barnizado, guías de acero barnizado gris metalizado o blanco mate. Schiebetüren aus pulverbeschichtetem Stahl, Schienen aus grau metallic oder mattweiß pulverbeschichtetem Stahl.</p> <p>Con serratura - With lock - Avec serrure - Con cerradura - Mit Schloss.</p>	





	  	 	
CD.	4110-GM	4110-BO	6A63
PR.	€ 239,00	€ 239,00	€ 29,00 (10 pcs)
CL.	GM	BO	N
			
DS.	<p>Contenitore in acciaio verniciato. Case in powder-coated steel. Bac en acier peint. Recipiente en acero barnizado. Behälter aus pulverbeschichtetem Stahl.</p>		<p>Strisce adesive antiderapanti per art. 4110 Adhesive antislip strips for code 4110 Fonds adhésives antidérapants pour réf. 4110 Fondos antideslizantes adhesivos para ref. 4110 Selbstklebende Gleitschutzstreifen für Art. 4110</p>

	<p>Solo per ripiani art: Only for shelves code: Seulement pour tablettes réf: Solo para estantes ref: Nur für Regalböden Art: 4012</p>  
CD.	2679
PR.	€ 267,00
CL.	
DS.	<p>Espositore/emerooteca in metacrilato traslucido a tre ante, supporti in acciaio grigio metallizzato. Display/magazine rack with 3 flap panels in translucent methacrylate, metal grey steel supports. Présentoir à revues à 3 volets en méthacrylate translucide, supports en acier gris métallisé. Expositor en metacrilato traslucido a tres puertas, soportes en acero barnizado gris metalizado. Magazinaussteller mit 3 Klappen aus durchsichtigem Methacrylat, Träger aus Stahl, grau metallic.</p>



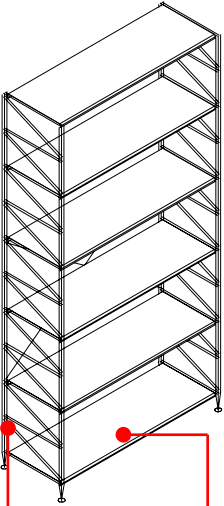
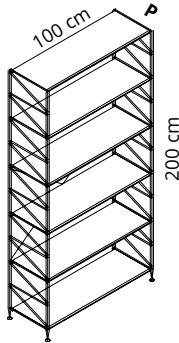
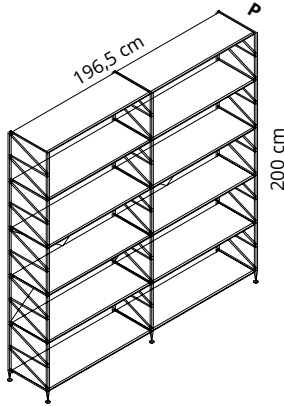
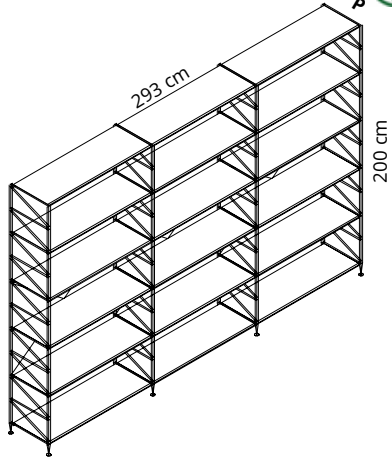





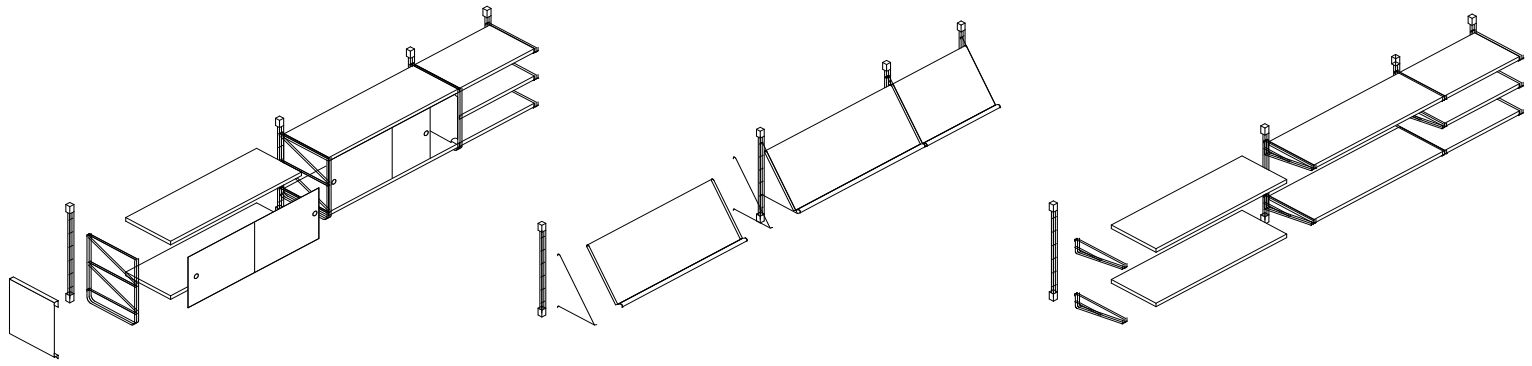
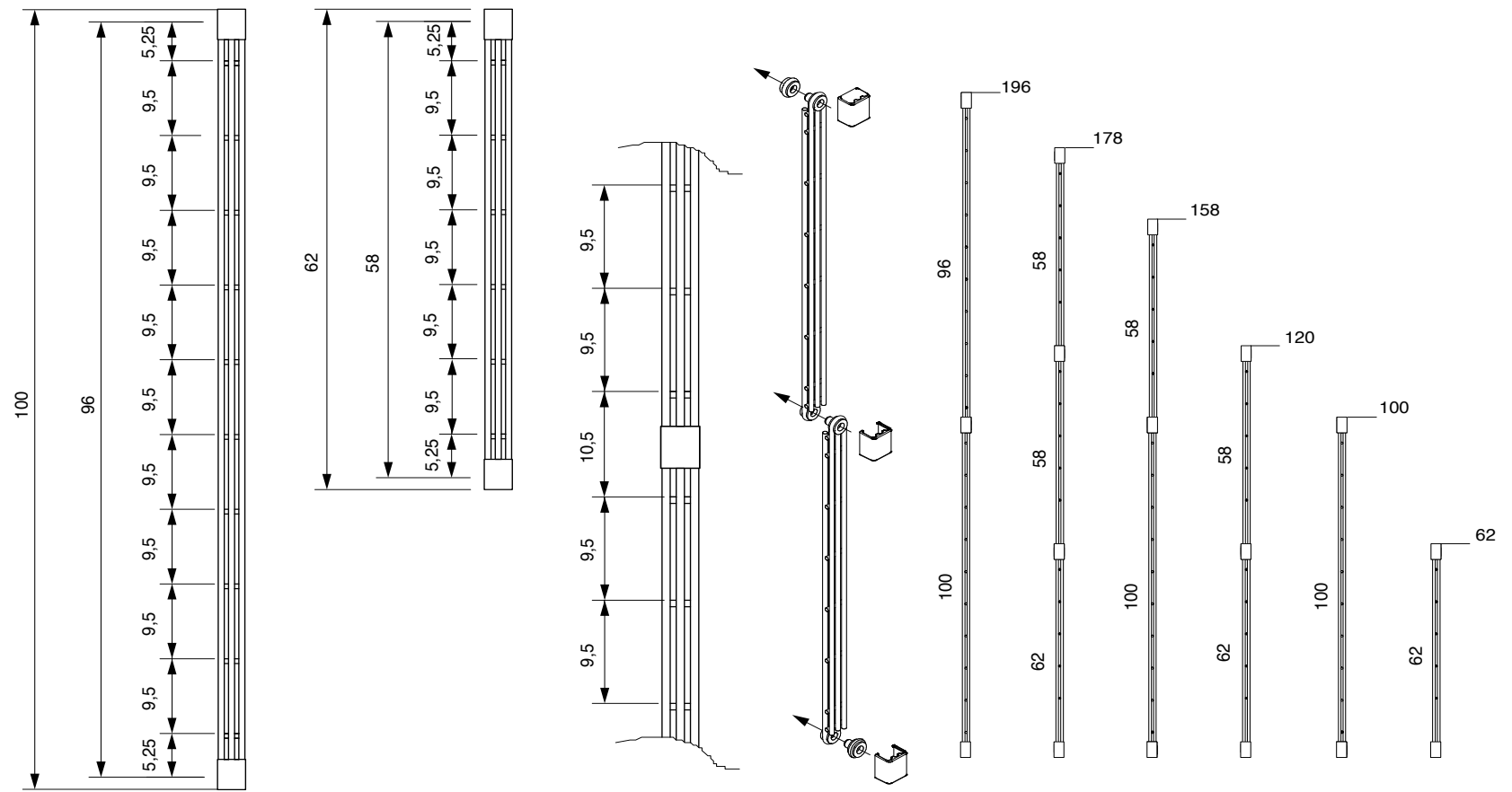

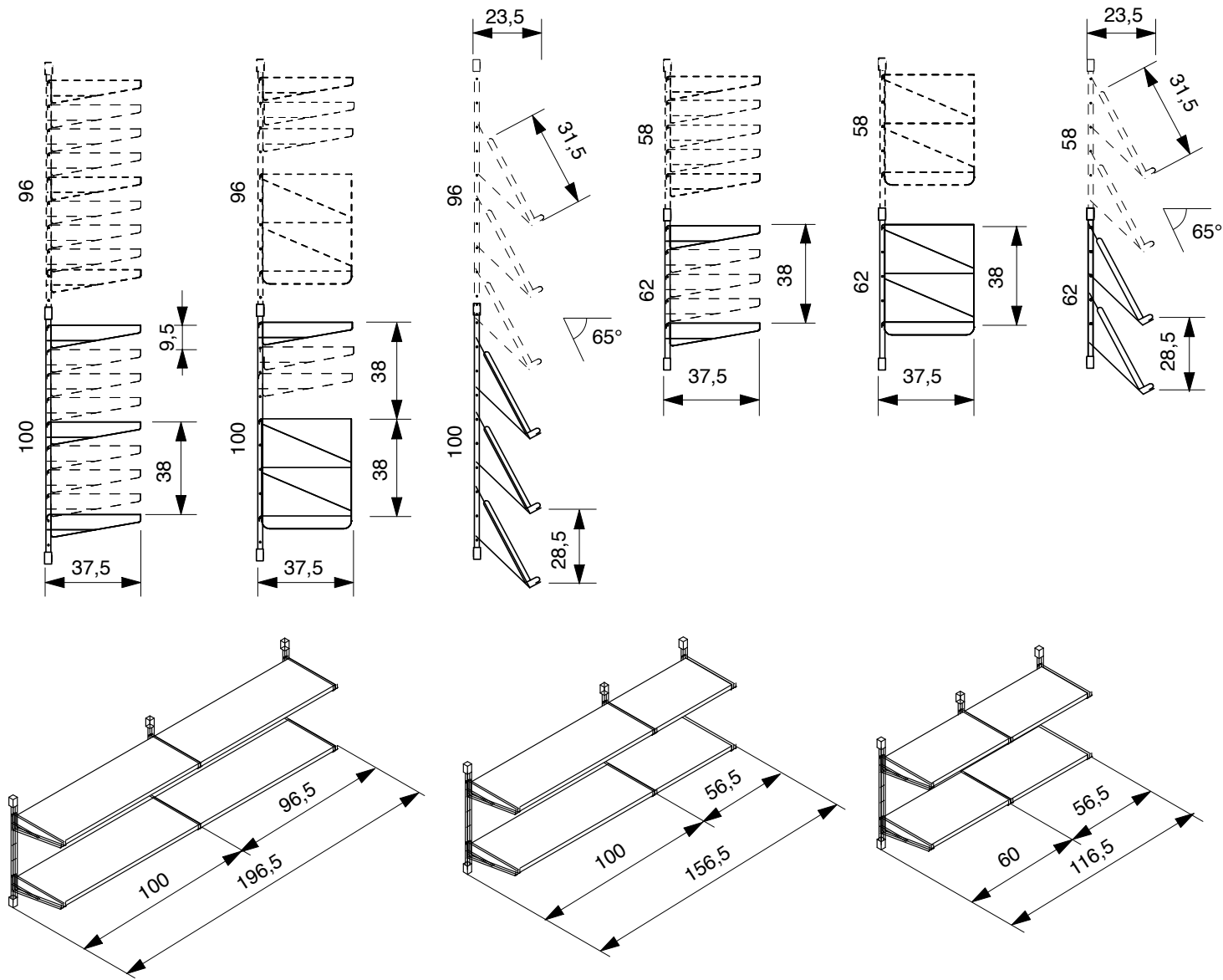

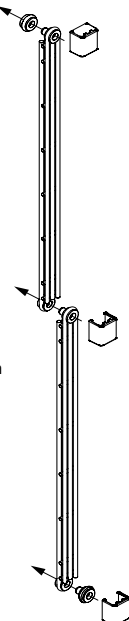

	 		 		<p>Per ripiani art: For shelves code: Pour tablettes réf: Para estantes ref: Für Regalböden Art: 4012, 4062</p>   	
CD.	2862-GM	2862-BO	2746-GM	2746-BO	6A52	
PR.	€ 97,00	€ 97,00	€ 17,00	€ 17,00	€ 54,00 (10 pcs)	
CL.	GM	BO	GM	BO	T	
						
DS.	<p>Portabiti/poggiapiedi in acciaio verniciato e tubo cromato. Profondità regolabile. Powder-coated steel clothes-hangers/foot-rest and chrome-plated rod. Adjustable depth. Portemanteaux/repose-pieds en acier peint et tige en acier chromé. Réglable en profondeur. Perchero/reposapiés en acero y barra en acero cromado. Regulable en profundidad. Garderobenstange/Fußstütze aus beschichtetem Stahl und Stange aus verchromtem Stahl. Verstellbarer Tiefe.</p>		<p>Bandiera segnaletica in acciaio verniciato. Powder-coated steel sign banner. Bande signalétique en acier peint. Placa de señalización en acero barnizado. Beschriftungsschild aus pulverbeschichtetem Stahl.</p>		<p>Segnaletica per ripiani con bordo tondo. Sign system for round edge shelves. Signalisation pour tablettes avec bord rond. Señalización para estantes borde redondo. Beschilderung für Tablare mit abgerundeter Kante.</p>	
	  		  		<p>Per art.: For ref.: Pour réf.: Para ref.: Für Art.: 6A2272, 6A2274</p>   	
CD.	6A2272 (GM)	6A2272 (BO)	6A2274 (GM)	6A2274 (BO)	6A2278 (GM)	6A2278 (BO)
PR.	€ 55,00	€ 55,00	€ 48,00	€ 48,00	€ 29,00 (2 pcs)	€ 29,00 (2 pcs)
CL.	GM	BO	GM	BO	GM	BO
						
DS.	<p>Fascioni segnaletici in acciaio verniciato. Powder-coated steel sign bands. Panneaux signalétiques en acier peint. Bandas de señalización en acero barnizado. Beschriftungspaneele aus pulverbeschichtetem Stahl.</p>				<p>Supporti fascione segnaletico. Supports for sign bands. Supports pour panneaux signalétiques. Soportes para bandas de señalización. Halterung für Beschriftungspaneele.</p>	

CD.	2646-GM	2646-BO	2995/46-GM	2995/46-BO
PR.	€ 38,00	€ 38,00	€ 45,00	€ 45,00
CL.	GM	BO	GM	BO
DS.	<p>Coppia staffe per fissaggio a terra dei montanti. Da utilizzare in caso di moduli non fissati a parete. Couple of brackets for side uprights fixing to the floor. To be used only for modules not attached to the wall. Paire d'étriers de fixation au sol pour montants. A utiliser pour modules qui ne sont pas fixés au mur. 2 fijación al suelo para laterales. Para ser usados solamente en el caso de los módulos no fijados a la pared. Ein Paar Halterungen zur Befestigung der Seitensteher am Boden. Nur zur Verwendung bei Elementen, welche nicht an der Wand befestigt werden.</p>		<p>2 giunti trasparenti per unione bifronte e 2 staffe per fissaggio a terra dei montanti. 2 transparent joints for double-sided connection + 2 brackets to fix uprights to the floor. 2 joints transparents pour accouplement bifrontal et 2 étrier fixation au sol pour montants. 2 juntas transparentes para conexión bifrontal y 2 fijación al suelo para laterales. 2 Doppelseitige Module und 2 Klammer zur Bodenbefestigung von Seitenteilen.</p>	
CD.	2996-GM	4994-GM	4994-BO	3973-GM
PR.	€ 19,00	€ 22,00	€ 22,00	€ 39,00
CL.	GM	GM	BO	GM
DS.	<p>Coppia di squadrette per unione montanti a 90°. Pair of joints for 90° side uprights connection. Paire de joints pour union montants à 90°. Par de juntas para conexión de laterales a 90°. 2 Beschläge für Seitenteileckkombinationen 90°.</p>		<p>Staffa per fissaggio a parete dei montanti. Steel bracket used to fix side upright to wall. Etrier de fixation au mur pour montants. Fijación a pared para laterales. Klammer für Wandbefestigung der Seitenteile.</p>	
	<p>Per art. / For ref. / Pour réf. / Para ref. / Für Art. 4012 ATTENZIONE: 1 3973-GM per/for 1 code 4012</p>		<p>Per art. / For ref. / Pour réf. / Para ref. / Für Art. 4062 ATTENZIONE: 1 3974-GM per/for 1 code 4062</p>	
CD.			3973-GM	3974-GM
PR.			€ 39,00	€ 38,00
CL.			GM	GM
DS.			<p>2 rinforzi in acciaio verniciato per ripiani Top posizionati ad altezza 100 cm o inferiore. 2 strengthenings for top shelves on units 100 cm high or lower. 2 renforcements tablette dessus, pour modules en hauteur 100 cm ou inférieure. 2 refuerzos para estante superior situado a una altura de 100 cm o inferior. 2 Verstärkung für oberen Regalböden bei einer Regalhöhe von 100 cm oder niedriger.</p>	

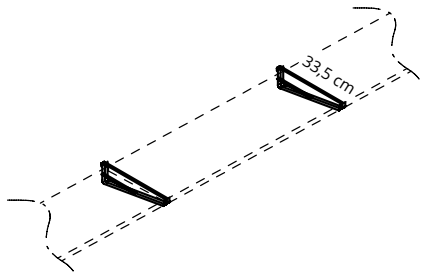
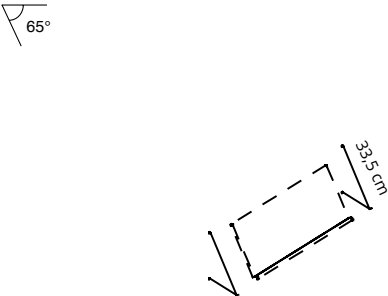
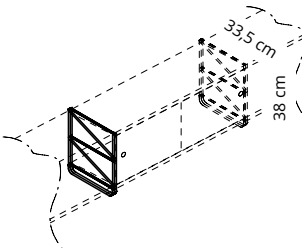









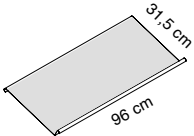
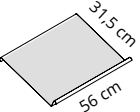

								
	<p>P = 35 cm</p>		<p>P = 45 cm</p>		<p>P = 35 cm</p>		<p>P = 45 cm</p>	
	 	<p>Cod: SCR132-GM € 717,00</p> <p>2 ref 3200-GM 1 ref 2910-GM 6 ref 3012-GM</p>	<p>Cod: SCR133-GM € 783,00</p> <p>2 ref 4200-GM 1 ref 2910-GM 6 ref 4012-GM</p>	<p>Cod: SCR134-GM € 1.296,00</p> <p>3 ref 3200-GM 2 ref 2910-GM 12 ref 3012-GM</p>	<p>Cod: SCR135-GM € 1.419,00</p> <p>3 ref 4200-GM 2 ref 2910-GM 12 ref 4012-GM</p>	<p>Cod: SCR136-GM € 1.875,00</p> <p>4 ref 3200-GM 3 ref 2910-GM 18 ref 3012-GM</p>	<p>Cod: SCR137-GM € 2.055,00</p> <p>4 ref 4200-GM 3 ref 2910-GM 18 ref 4012-GM</p>	
 	<p>Cod: SCR132-BO € 717,00</p> <p>2 ref 3200-BO 1 ref 2910-BO 6 ref 3012-BO</p>	<p>Cod: SCR133-BO € 783,00</p> <p>2 ref 4200-BO 1 ref 2910-BO 6 ref 4012-BO</p>	<p>Cod: SCR134-BO € 1.296,00</p> <p>3 ref 3200-BO 2 ref 2910-BO 12 ref 3012-BO</p>	<p>Cod: SCR135-BO € 1.419,00</p> <p>3 ref 4200-BO 2 ref 2910-BO 12 ref 4012-BO</p>	<p>Cod: SCR136-BO € 1.875,00</p> <p>4 ref 3200-BO 3 ref 2910-BO 18 ref 3012-BO</p>	<p>Cod: SCR137-BO € 2.055,00</p> <p>4 ref 4200-BO 3 ref 2910-BO 18 ref 4012-BO</p>		
<p>Scaffalatura con montanti e crociere in tondino di acciaio verniciato colore grigio metallizzato o bianco opaco, ripiani in acciaio pieno verniciato grigio metallizzato o bianco opaco e piedini in tecnopolimero. Shelving unit with uprights and bracing crosses in metal grey or mat white powder-coated steel rod, shelves in metal grey or mat white powder-coated steel and feet in high-tech polymer. Rayonnage avec montants et croisillons en rond d'acier gris métal ou blanc mat, tablettes en acier peint gris métal ou blanc mat et vérins en technopolymère. Estantería con laterales y soportes traseros en varilla de acero barnizado color gris metalizado o blanco mate, estantes en acero barnizado gris metalizado o blanco mate y patas en polímero. Regal mit Seitenteile und Stabilisierungskreuze aus beschichtetem Stahlrohr, grau metallic oder mattweiß, Regalböden aus beschichtetem Stahl, grau metallic oder mattweiß, und Füße aus Technopolymer.</p>								





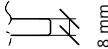
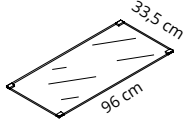
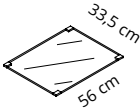





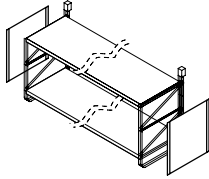
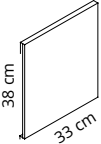
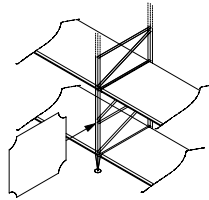
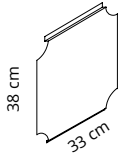

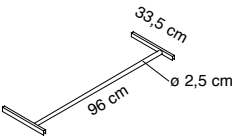

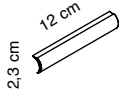
	 100 cm				 62 cm		 <p>I montanti si possono sormontare. The uprights can be overlapped. Les montants se peuvent superposer. Los laterales se pueden superponer. Die Seitenteile können übereinandergelegt werden.</p>
CD.	2402-GM	2402-BO	2400-GM	2400-BO			
PR.	€ 58,00	€ 58,00	€ 49,00	€ 49,00			
CL.	GM	BO	GM	BO			
							
DS.	<p>Montanti in acciaio verniciato con polveri epossidiche. Portata max. 50 Kg. Powder-coated steel side uprights. Maximum load 50 Kg. Montants en acier peint en époxy. Charge utile 50 Kg. Laterales en acero barnizado con polvos epoxídicos. Cargo máximo 50 Kgs. Seitenleisten aus mit Epoxypulver beschichtetem Stahl. Tragfähigkeit max. 50 kg.</p>						
	 33,5 cm		 65° 33,5 cm		 33,5 cm 38 cm		
CD.	2420-GM	2420-BO	2429-GM	2429-BO	2430-GM	2430-BO	
PR.	€ 46,00 (2 pcs)	€ 46,00 (2 pcs)	€ 46,00	€ 46,00	€ 68,00	€ 68,00	
CL.	GM	BO	GM	BO	GM	BO	
							
DS.	<p>Supporti in acciaio verniciato per ripiani dritti. Powder-coated steel supports for flat shelves. Supports en acier peint pour tablettes à plat. Soportes en acero barnizado para estantes rectos. Halterungen aus pulverbeschichtetem Stahl für flache Regalböden.</p>		<p>Coppia di supporti in acciaio verniciato per ripiani inclinati art. 3910, 3960. Pair of powder-coated steel supports for inclined shelves code 3910, 3960. Paire de supports en acier peint pour tablettes inclinées réf. 3910, 3960. Par de soportes en acero barnizado para estantes inclinados ref. 3910, 3960. 2 Halterungen aus pulverbeschichtetem Stahl für schräge Regalböden Art. 3910, 3960.</p>		<p>Montante in acciaio verniciato per ante scorrevoli. Powder-coated steel side upright for sliding closings. Montant en acier peint pour fermetures coulissantes. Laterales en acero barnizado para puertas deslizables. Seitenteile aus pulverbeschichtetem Stahl für Schiebetüren.</p>		

CD.	3012-GM		3062-GM	
PR.	€ 66,00		€ 65,00	
CL.	GM		GM	
DS.	<p>Ripiani in acciaio verniciato con polveri epossidiche, spessore 23 mm. Powder-coated steel shelves, 23mm thick. Tablettes en acier peint en époxy, épaisseur 23 mm. Estantes en acero barnizado con polvos epoxidicos, espesor 23 mm. Regalböden aus Epoxypulver beschichtetem Stahlblech, Stärke 23 mm.</p>			
CD.	3010-GM		3060-GM	
PR.	€ 84,00		€ 76,00	
CL.	GM		GM	
DS.	<p>Ripiani in acciaio microforato verniciato con polveri epossidiche, spessore 23 mm. Powder-coated micro-perforated steel shelves, 23mm thick. Tablettes en acier microperforé peint en époxy, épaisseur 23 mm. Estantes en acero microperforado barnizado con polvos epoxidicos, espesor 23 mm. Regalböden aus gelochtem, mit Epoxypulver beschichtetem Stahlblech, Stärke 23 mm.</p>			

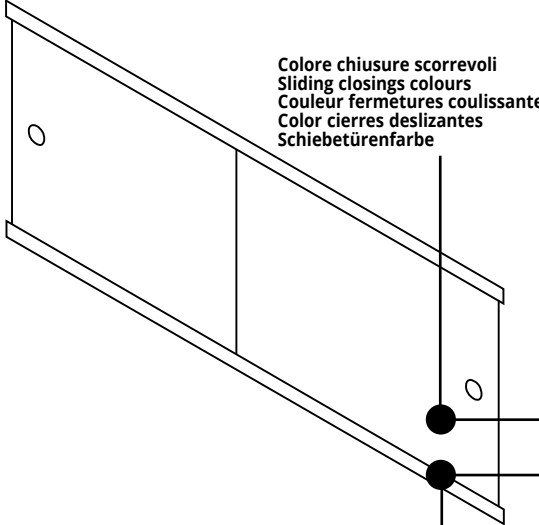

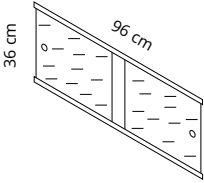
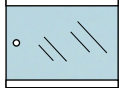
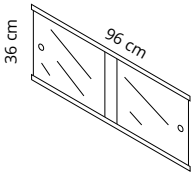
				
				
CD.	3910-GM	3910-BO	3960-GM	3960-BO
PR.	€ 97,00	€ 97,00	€ 84,00	€ 84,00
CL.	GM	BO	GM	BO
				
DS.	<p>Ripiani espositori inclinati in acciaio microforato verniciato con polveri epossidiche. Inclined display shelves in powder-coated micro-perforated steel. Tablettes/présentoirs inclinés en acier microperforé peint en époxy. Estantes expositores inclinados en acero microperforado barnizado con polvos epoxidicos. Schrägtabulare aus gelochtem, mit Epoxypulver beschichtetem Stahl</p>			
				
				
CD.	3014-GR	3014-BO	3064-GR	3064-BO
PR.	€ 98,00	€ 98,00	€ 89,00	€ 89,00
CL.				
				
DS.	<p>Ripiani in vetro temperato trasparente spessore 8 mm, supporti in tecnopolimero grigio o bianco. Transparent tempered glass shelves, 8 mm thick. Grey or white supports. Tablettes en verre trempé transparent épaisseur 8 mm, supports gris ou blancs. Estantes en cristal templado transparente espesor 8 mm, soportes gris o blancos. Regalböden aus gehärtetem Sicherheitsglas transparent, Stärke 8 mm, graue oder weiße Halterungen.</p>			

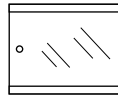
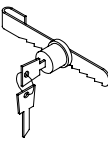
	 		 	
CD.	2625-GM		2625-BO	
PR.	€ 78,00 (2 pcs)		€ 78,00 (2 pcs)	
CL.	GM		BO	
				
DS.	<p>Chiusure esterne in acciaio. Steel external closings. Fermetures externes en acier. Cierres externas en acero. Außenverkleidungen aus Stahl.</p>		<p>Chiusure interne in acciaio. Steel internal closing elements. Fermetures internes en acier. Cierres internas en acero. Innenverkleidungen aus Stahl.</p>	
			<p>Per ripiani art: For shelves code: Pour tablettes réf: Para estantes ref: Für Regalböden Art: 3010, 3060, 3012, 3062, 3910, 3960</p>   	
CD.	2812-GM		2812-BO	
PR.	€ 96,00		€ 96,00	
CL.	GM		BO	
				
DS.	<p>Portabiti in acciaio verniciato e tubo cromato. Profondità regolabile. Powder-coated steel clothes-hangers and chrome-plated rod. Adjustable depth. Portemanteaux en acier peint et tige en acier chromé. Réglable en profondeur. Perchero en acero barnizado y barra en acero cromado. Regulable en profundidad. Garderobenstange: beschichtetem Stahl und Stange verchromtem Stahl. Verstellbarer Tiefe.</p>		<p>Segnaletica per ripiani con bordo tondo. Sign system for round edge shelves. Signalisation pour tablettes avec bord rond. Señalización para estantes borde redondo. Beschriftungssystem für Tablare mit abgerundeter Kante.</p>	

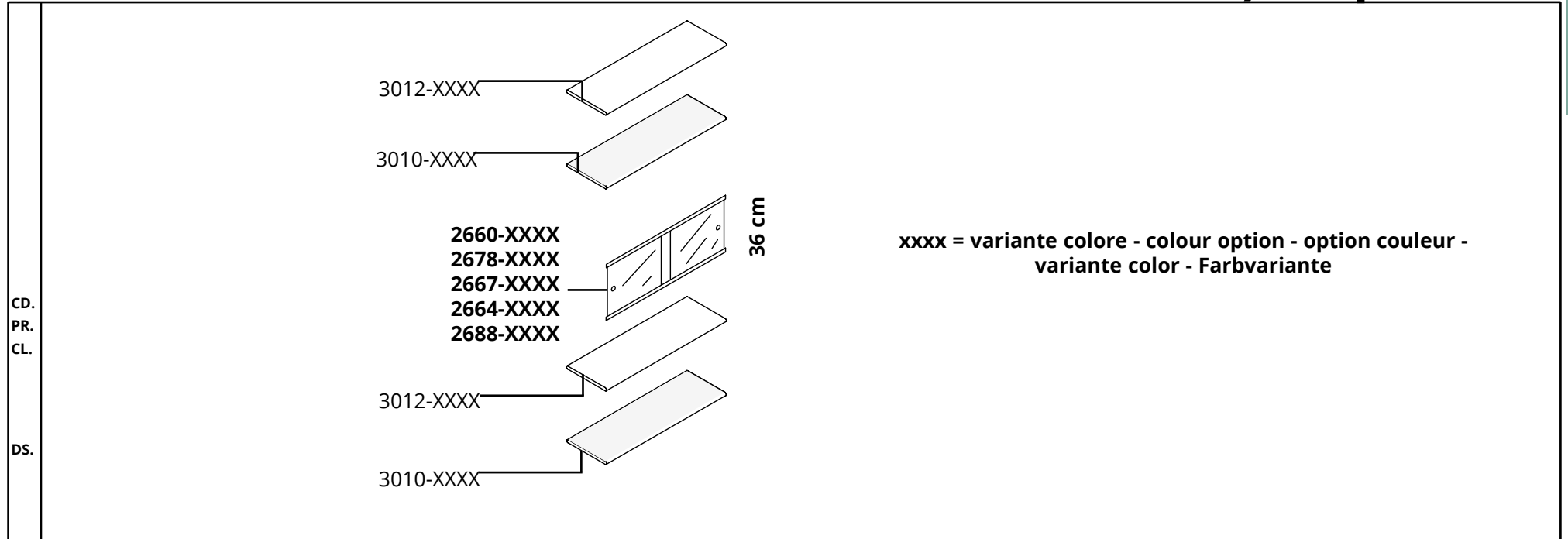
 <p>Colore chiusure scorrevoli Sliding closings colours Couleur fermetures coulissantes Color cierres deslizantes Schiebetürenfarbe</p> <p>Colore guide Slides colours Couleur glissières Color guías Schienenfarbe</p>	<p>Per piano superiore in metallo (vedi pag.47) For steel upper shelf (see page 47) Pour tablette supérieure en acier (voir page 47) Para estante superior en acero (ver pag. 47) Wenn oberes Tablar aus Stahl (Seite 47)</p> <p>CD. 2667-GM</p> <p>PR. € 158,00</p> <p>CL. </p> <p>DS. Chiusure scorrevoli in vetro satinato/acidato, guide in acciaio verniciato grigio metallizzato o bianco opaco. Satin glass sliding closings, slides in metal grey or mat white powder-coated steel. Fermetures coulissantes en verre satiné, glissières en acier peint gris métalisé ou blanc mat. Cierres deslizantes en cristal satinado, guías en acero barnizado gris metalizado o blanco mate. Schiebetüren aus satiniertem Glas, Schienen aus grau metallic oder mattweiß pulverbeschichtetem Stahl.</p>	 <p>CD. 2667-BO</p> <p>PR. € 158,00</p> <p>CL. </p>
<p>Per piano superiore in metallo (vedi pag.47) For steel upper shelf (see page 47) Pour tablette supérieure en acier (voir page 47) Para estante superior en acero (ver pag. 47) Wenn oberes Tablar aus Stahl (Seite 47)</p>  <p>CD. 2664-GM</p> <p>PR. € 137,00</p> <p>CL. </p> <p>DS. Chiusure scorrevoli in vetro trasparente, guide in acciaio verniciato grigio metallizzato o bianco opaco. Transparent glass sliding closings, slides in metal grey or mat white powder-coated steel. Fermetures coulissantes en verre transparent, glissières en acier peint gris métalisé ou blanc mat. Cierres deslizantes en cristal transparente, guías de acero barnizado gris metalizado o blanco mate. Schiebetüren aus transparentem Glas, Schienen aus grau metallic oder mattweiß pulverbeschichtetem Stahl.</p>	<p>CD. 2664-BO</p> <p>PR. € 137,00</p> <p>CL. </p>	 <p>CD. 2659</p> <p>PR. € 22,00</p> <p>DS. Serratura per chiusure in vetro per: Lock for glass closing for: Serrure pour fermetures en verre pour: Cerradura para cierre en cristal para: Schloss für Glasschiebetüren für: art. 2664-BO / 2664-GM</p>

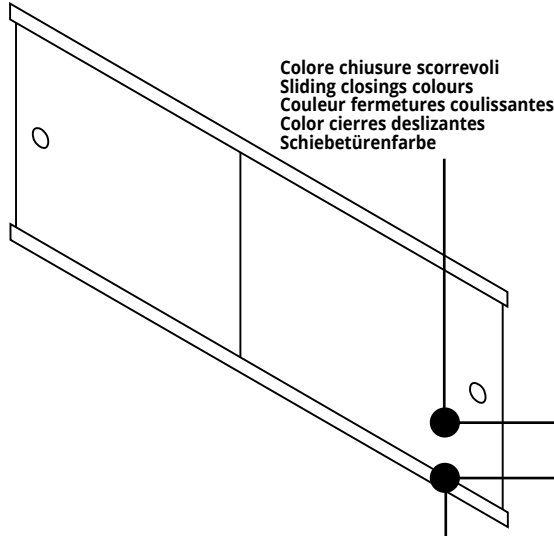
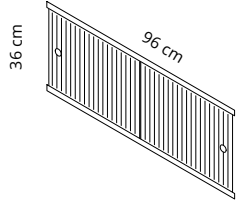

	<p>Per piano superiore in metallo (vedi pag.47) For steel upper shelf (see page 47) Pour tablette supérieure en acier (voir page 47) Para estante superior en acero (ver pag. 47) Wenn oberes Tablar aus Stahl (Seite 47)</p>	<p>Per piano superiore in metallo (vedi pag.47) For steel upper shelf (see page 47) Pour tablette supérieure en acier (voir page 47) Para estante superior en acero (ver pag. 47) Wenn oberes Tablar aus Stahl (Seite 47)</p>		
CD.	2660-GMGM	2660-BOBO	2678-GMGM	
PR.	€ 108,00	€ 108,00	€ 168,00	
CL.				
DS.	<p>Chiusure scorrevoli in acciaio verniciato, guide in acciaio verniciato grigio metallizzato o bianco opaco. Powder-coated steel sliding closings, slides in metal grey or mat white powder-coated steel. Fermetures coulissantes en acier peint, glissières en acier peint gris métalisé ou blanc mat. Cierres deslizantes en acero barnizado, guías de acero barnizado gris metalizado o blanco mate. Schiebetüren aus pulverbeschichtetem Stahl, Schienen aus grau metallic oder mattweiß pulverbeschichtetem Stahl.</p>		<p>Chiusure scorrevoli in acciaio verniciato, guide in acciaio verniciato grigio metallizzato o bianco opaco. Powder-coated steel sliding closings, slides in metal grey or mat white powder-coated steel. Fermetures coulissantes en acier peint, glissières en acier peint gris métalisé ou blanc mat. Cierres deslizantes en acero barnizado, guías de acero barnizado gris metalizado o blanco mate. Schiebetüren aus pulverbeschichtetem Stahl, Schienen aus grau metallic oder mattweiß pulverbeschichtetem Stahl.</p> <p style="text-align: center;">Con serratura - With lock - Avec serrure - Con cerradura - Mit Schloss.</p>	

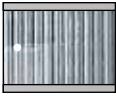
 <p>Colore chiusure scorrevoli Sliding closings colours Couleur fermetures coulissantes Color cierres deslizantes Schiebetürenfarbe</p> <p>Colore guide Slides colours Couleur glissières Color guías Schienenfarbe</p>	<p>Per piano superiore in metallo (vedi pag.47) For steel upper shelf (see page 47) Pour tablette supérieure en acier (voir page 47) Para estante superior en acero (ver pag. 47) Wenn oberes Tablar aus Stahl (Seite 47)</p> 		
	<p>CD.</p> <p>PR.</p> <p>CL.</p>	<p>2688-GM € 168,00</p> 	
	<p>DS.</p> <p>Chiusure scorrevoli in vetro cannettato, guide in acciaio verniciato grigio metallizzato o bianco opaco. Ribbed glass sliding closings, slides in metal grey or mat white powder-coated steel. Fermetures coulissantes en verre cannelé, glissières en acier peint gris métallisé ou blanc mat. Cierres deslizantes en cristal acanalado, guías de acero barnizado gris metalizado o blanco mate. Schiebetüren aus mit geripptem Glas, Schienen aus grau metallic oder mattweiß pulverbeschichtetem Stahl.</p>		

<p>Per piano superiore in metallo (vedi pag.47) For steel upper shelf (see page 47) Pour tablette supérieure en acier (voir page 47) Para estante superior en acero (ver pag. 47) Wenn oberes Tablar aus Stahl (Seite 47)</p> 	<p>CD.</p> <p>2660-LGM</p> <p>2660-LBO</p>		<p>1</p> 	<p>2</p> 
	<p>PR.</p> <p>€ 248,00</p>	<p>€ 248,00</p>		
	<p>CL.</p> 	<p>CL.</p> 	<p>3</p> 	<p>4</p> 
<p>DS.</p> <p>Chiusure scorrevoli in MDF placcato alluminio impiallacciato legno Noce Canaletto, da un lato, e Rovere, dall'altro lato. Guide in acciaio verniciato grigio metallizzato o bianco opaco. Closing slides in MDF, aluminum plated that are walnut veneered on one side and oak veneered on the other. Slides in metal grey or mat white powder-coated steel. Fermetures coulissantes en MDF plaqué aluminium et contre-plaqué en noyer Canaletto d'une coté et rouvre de l'autre. Glissières en acier peint gris métallisé ou blanc mat. Cierres deslizantes en MDF, aluminio plateado que en un lado es nogal y en el otro lado es roble. Guías de acero barnizado gris metalizado o blanco mate. Schiebetüren aus mit Aluminium verkleidetem MDF mit Walnussfurnier auf der einen und Eichenfurnier auf der anderen Seite. Schiebetüren aus metallgrau oder mattweiß pulverbeschichtetem Stahl.</p>				

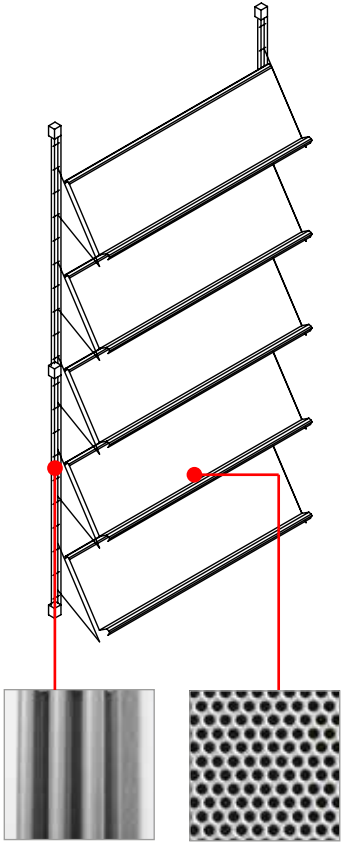
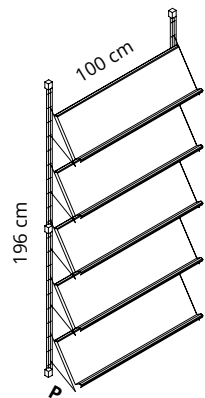
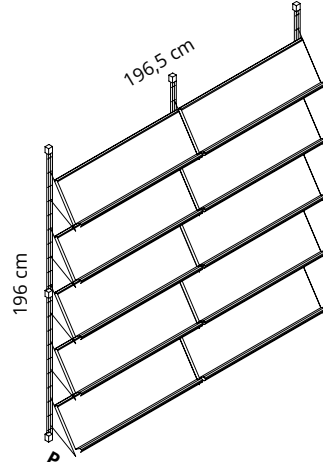
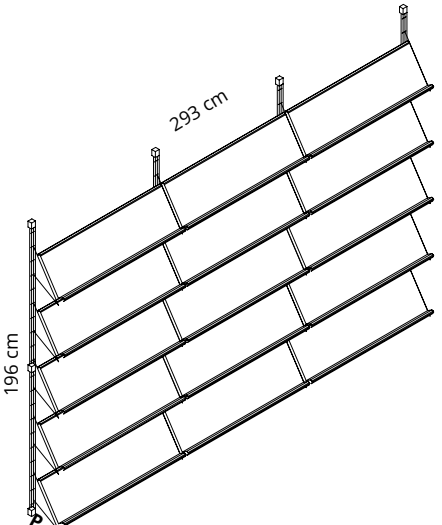
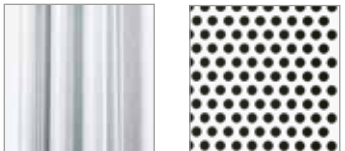
			
	<p>P = 23,5 cm</p> <p>Cod: SCR162-GM € 947,00</p> <p>4 ref 2402-GM 5 ref 2429-GM 5 ref 3910-GM</p>	<p>P = 23,5 cm</p> <p>Cod: SCR163-GM € 1.778,00</p> <p>6 ref 2402-GM 10 ref 2429-GM 10 ref 3910-GM</p>	<p>P = 23,5 cm</p> <p>Cod: SCR164-GM € 2.609,00</p> <p>8 ref 2402-GM 15 ref 2429-GM 15 ref 3910-GM</p>
<p>Cod: SCR162-BO € 947,00</p> <p>4 ref 2402-BO 5 ref 2429-BO 5 ref 3910-BO</p>	<p>Cod: SCR163-BO € 1.778,00</p> <p>6 ref 2402-BO 10 ref 2429-BO 10 ref 3910-BO</p>	<p>Cod: SCR164-BO € 2.609,00</p> <p>8 ref 2402-BO 15 ref 2429-BO 15 ref 3910-BO</p>	<p>Cod: SCR164-BO € 2.609,00</p> <p>8 ref 2402-BO 15 ref 2429-BO 15 ref 3910-BO</p>
<p>Scaffalatura con montanti in tondino di acciaio verniciato colore grigio metallizzato o bianco opaco, ripiani in acciaio microforato verniciato grigio metallizzato o bianco opaco. Shelving unit with uprights in metal grey or mat white powder-coated steel rod, shelves in metal grey or mat white powder-coated micro-perforated steel. Rayonnage avec montants en rond d'acier gris métal ou blanc mat, tablettes en acier microperforé peint gris métal ou blanc mat. Estantería con laterales en varilla de acero barnizado color gris metalizado o blanco mate, estantes en acero microperforado barnizado gris metalizado o blanco mate. Regal mit Seitenteile aus beschichtetem Stahlrohr, grau metallic oder mattweiß, Regalböden aus beschichtetem gelochtem Stahl, grau metallic oder mattweiß.</p>			

SOCRATE Outdoor

design

Mario Trimarchi

Caimi Lab

I_Socrate Outdoor è un sistema d'arredo per esterno, modulare e componibile, pensato come un elemento polivalente dotato di accessori che lo rendono funzionale per svariati utilizzi outdoor, per piccoli e grandi spazi. Composto da una struttura base fatta di montanti, crociere e griglie, realizzati in tondino di acciaio zincato e verniciato e da ripiani in metallo, in marmo, piani portavasi, griglie e contenitori realizzati in acciaio inox o zincato e verniciato. I differenti colori di strutture, ripiani e accessori possono essere combinati fra loro per un inedito effetto cromatico.

EN_Socrate Outdoor refers to a system of modular outdoor furniture. Socrate Outdoor items are designed to be multifunctional and come equipped with accessories for adapting them to any one of the various uses to which they can be put in a given place, be it small or large. Each item in the range consists of a basic frame of uprights, bracing crosses and grids of galvanized and coated steel that support metal or marble shelves, planter holders, meshes and containers made either of stainless steel or of powder-coated galvanized steel. Available in a variety of colours, the basic structures, shelves and accessories can be mixed and matched to achieve a personalized chromatic effect.

F_Socrate Outdoor est un système de mobilier d'extérieur, modulaire et assemblable, conçu comme un élément polyvalent avec des accessoires qui le rendent apte à diverses utilisations en extérieur, pour des espaces petits ou grands. Il se compose d'une structure de base comprenant des montants, des croisillons et grilles en tige d'acier galvanisé peint et des étagères en métal, en marbre, des tablettes porte-pots, des grilles et des récipients en acier inoxydable ou galvanisé et peint. Les différentes couleurs des structures, étagères et accessoires peuvent être assemblées entre elles pour obtenir un effet chromatique inédit.











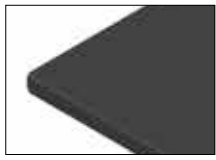
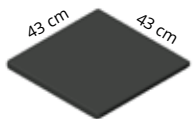
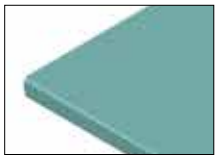
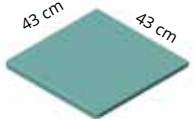

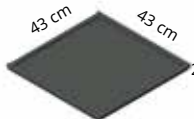
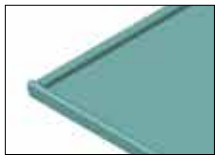
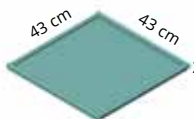

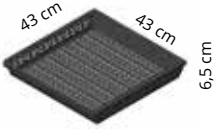

D_Socrate Outdoor ist ein modulares Einrichtungssystem aus kombinierbaren Elementen für den Außenbereich. Es basiert auf dem Konzept eines durch Zubehör großen oder kleinen Räumen sowie verschiedenen Außenraum-Funktionen anpassbaren Mehrzweckelementes. Die Grundstruktur sieht Ständer, Kreuzelemente und Gitterelemente aus verzinktem und lackiertem Stahlrohr sowie Regalböden aus Metall und Marmor, Pflanzenablageflächen, Gitter und Behälter aus rostfreiem bzw. verzinktem und lackiertem Stahl vor. Die unterschiedlichen Farben der Strukturelemente, Regalböden und Zubehörelemente können miteinander kombiniert werden, um überraschende Farbeffekte zu erzielen.

E_Socrate Outdoor es un sistema modular de decoración para exteriores, concebido como elemento versátil que incorpora diversos accesorios para resultar más funcional a los diferentes espacios, tanto de pequeño como de gran tamaño. Consta de una estructura básica con montantes, crucetas y rejillas de acero galvanizado y pintado y de estantes de metal, mármol, repisas porta macetas, rejillas y contenedores de acero inoxidable o galvanizado y pintado. Se pueden combinar los diferentes colores de las estructuras, estantes y accesorios para conseguir un efecto cromático original.

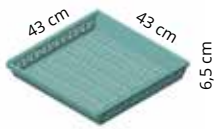

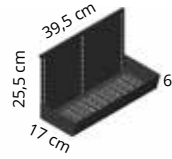
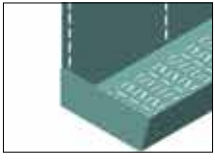
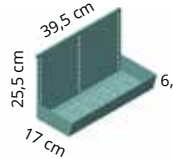





CD.	4600E-AN	4600E-TU	4800E-AN	4800E-TU	
PR.	€ 196,00	€ 196,00	€ 155,00	€ 155,00	
CL.	AN	TU	AN	TU	
DS.	<p>Grigio antracite Anthracite grey Gris anthracite Gris antracita Anthrazitgrau</p>	<p>RAL 6034</p>	<p>Grigio antracite Anthracite grey Gris anthracite Gris antracita Anthrazitgrau</p>	<p>RAL 6034</p>	
<p>Montanti con piedini di appoggio regolabili in acciaio zincato e verniciato con polveri epossidiche per esterni. Uprights with adjustable support feet made of galvanized steel and epoxy powder coated for outdoor use. Montants avec pieds d'appui réglables en acier galvanisé et peints avec poudres époxy pour extérieur. Montantes con pies de apoyo ajustables de acero galvanizado y pintado con polvos epoxi para exteriores. Seitenteile aus verzinktem, mit Epoxypulver für den Außenbereich beschichtetem Stahl mit verstellbaren Füßen.</p>					
CD.	2940E-AN	2940E-TU	4700E-AN	4700E-TU	4750E-I
PR.	€ 49,00	€ 49,00	€ 198,00	€ 198,00	€ 16,00
CL.	AN	TU	AN	TU	I
DS.	<p>Grigio antracite Anthracite grey Gris anthracite Gris antracita Anthrazitgrau</p>	<p>RAL 6034</p>	<p>Grigio antracite Anthracite grey Gris anthracite Gris antracita Anthrazitgrau</p>	<p>RAL 6034</p>	
<p>Crociere in acciaio zincato e verniciato con polveri epossidiche per esterni Bracing crosses made of galvanized steel, epoxy powder-coated for outdoor use. Croisillons en acier galvanisé et peints avec poudres époxy pour extérieur. Soportes traseros de acero galvanizado y pintado con polvos epoxi para exteriores. Kreuzelemente aus verzinktem, mit Epoxypulver für den Außenbereich beschichtetem Stahl</p> <p>Schienali in acciaio zincato e verniciato con polveri epossidiche per esterni. Backrests made of galvanized steel, epoxy powder-coated for outdoor use. Panneaux postérieurs en acier galvanisé et peints avec poudres époxy pour extérieur. Respaldos de acero galvanizado y pintado con polvos epoxi para exteriores. Rückenlehnen aus verzinktem, mit Epoxypulver für den Außenbereich beschichtetem Stahl</p> <p>Connettore in acciaio inox per collegamento 2 schienali Stainless steel rod for connecting 2 backrests. Raccord en acier inoxydable pour joindre 2 panneaux postérieurs Conector de acero inoxidable para juntar 2 respaldos. Edelstahl-Element zur Verbindung von zwei Rückenlehnen.</p>					

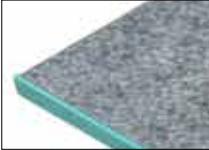
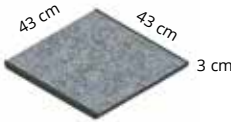
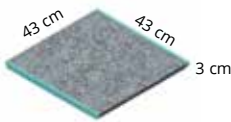

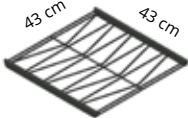
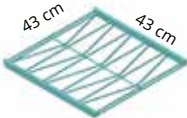
	 	 	 	 
CD.	4540E-AN	4540E-TU	4560E-AN	4560E-TU
PR.	€ 77,00	€ 77,00	€ 108,00	€ 108,00
CL.	AN	TU	AN	TU
DS.	 <p>Grigio antracite Anthracite grey Gris anthracite Gris antracita Anthrazitgrau</p>	 <p>RAL 6034</p>	 <p>Grigio antracite Anthracite grey Gris anthracite Gris antracita Anthrazitgrau</p>	 <p>RAL 6034</p>
	<p>Ripiani in acciaio zincato e verniciato con polveri epossidiche per esterni. Shelves made of galvanized steel, epoxy powder-coated for outdoor use. Étagères en acier galvanisé et peintes avec poudres époxy pour extérieur. Estantes de acero galvanizado y pintado con polvos epoxi para exteriores. Regalböden aus verzinktem, mit Epoxypulver für den Außenbereich beschichtetem Stahl.</p>		<p>Vaschette stagne in acciaio zincato e verniciato con polveri epossidiche per esterni. Watertight trays made of galvanized steel, epoxy powder-coated for outdoor use. Bacs étanches en acier galvanisé et peintes avec poudres époxy pour extérieur. Bandejas estancos de acero galvanizado y pintado con polvos epoxi para exteriores. Wasserdichte Schalen aus verzinktem, mit Epoxypulver für den Außenbereich beschichtetem Stahl.</p>	
	 	 	 	 
CD.	4570E-AN	4570E-TU	4530E-AN	4530E-TU
PR.	€ 119,00	€ 119,00	€ 87,00	€ 87,00
CL.	AN	TU	AN	TU
DS.	 <p>Grigio antracite Anthracite grey Gris anthracite Gris antracita Anthrazitgrau</p>	 <p>RAL 6034</p>	 <p>Grigio antracite Anthracite grey Gris anthracite Gris antracita Anthrazitgrau</p>	 <p>RAL 6034</p>
	<p>Vaschette in acciaio zincato e verniciato con polveri epossidiche per esterni. Trays made of galvanized steel, epoxy powder-coated for outdoor use. Bacs en acier galvanisé et peintes avec poudres époxy pour extérieur. Bandejas de acero galvanizado y pintado con polvos epoxi para exteriores. Schalen aus verzinktem, mit Epoxypulver für den Außenbereich beschichtetem Stahl.</p>		<p>Mensole in acciaio zincato e verniciato con polveri epossidiche per esterni. Solo per schienali 4700E-XX. Shelves made of galvanized steel, epoxy powder-coated for outdoor use. Only for backrests 4700E-XX. Étagères en acier galvanisé et peintes avec poudres époxy pour extérieur. Seulement pour dossiers 4700E-XX. Repisa de acero galvanizado y pintado con polvos epoxi para exteriores. Solo para respaldos 4700E-XX. Konsolen aus verzinktem, mit Epoxypulver für den Außenbereich I beschichtetem Stahl. Nur für Rückenlehnen 4700E-XX.</p>	

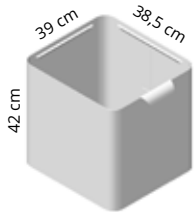
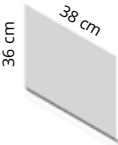
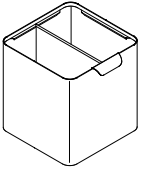

	    <p>4520E-ANS</p> <p>€ 378,00</p> <p>AN</p>	    <p>4580E-AN</p> <p>€ 88,00</p> <p>AN</p>
PR.	<p>€ 378,00</p>	<p>€ 88,00</p>
CL.	<p>AN</p>	<p>TU</p>
DS.	 <p>Grigio antracite Anthracite grey Gris anthracite Gris antracita Anthrazitgrau</p>	 <p>Grigio antracite Anthracite grey Gris anthracite Gris antracita Anthrazitgrau</p> <p>RAL 6034</p>
DS.	<p>Ripiani in granito Serizzo completi di sottopiano in acciaio zincato e verniciato con polveri epossidiche per esterni. Shelves made of Serizzo granite, with galvanized steel under counter that is epoxy powder-coated for outdoor use. Tablettes en granit Serizzo assorties d'un support en acier galvanisé et peintes avec poudres époxy pour extérieur. Estantes de granito Serizzo equipados con una base de acero galvanizado y pintado con polvos epoxi para exteriores. Regalböden aus Serizzo-Granit einschließlich Unterboden aus verzinktem, mit Epoxypulver für den Außenbereich beschichtetem Stahl</p>	<p>Ripiano in filo di acciaio zincato e verniciato con polveri epossidiche per esterni. Shelf made of galvanized steel wire, epoxy powder-coated for outdoor use. Tablette en fil d'acier galvanisé et peint avec poudres époxy pour extérieur. Estante de alambre de acero galvanizado y pintado con polvos epoxi para exteriores. Regalboden aus verzinktem, mit Epoxypulver für den Außenbereich beschichtetem Stahldraht.</p>
CD.	 <p>4590E-IS</p>	 <p>4591E-IS</p> <div style="border: 1px solid black; padding: 5px; display: inline-block;"> <p>4590E-IS + 4591E-IS</p>  </div>
PR.	<p>€ 249,00</p>	<p>€ 48,00</p>
CL.	<p>I</p>	<p>I</p>
DS.	 <p>Contenitore in acciaio inox con ruote. Stainless steel container with wheels. Conteneur en acier inoxydable avec roulettes. Contenedor de acero inox con ruedas. Edelstahlbehälter auf Rollen.</p>	 <p>Divisorio per contenitore in acciaio inox Stainless steel divider for containers. Séparateur pour conteneur en acier inoxydable. Separadores para contenedor de acero inox. Trennwand für Edelstahlbehälter.</p>

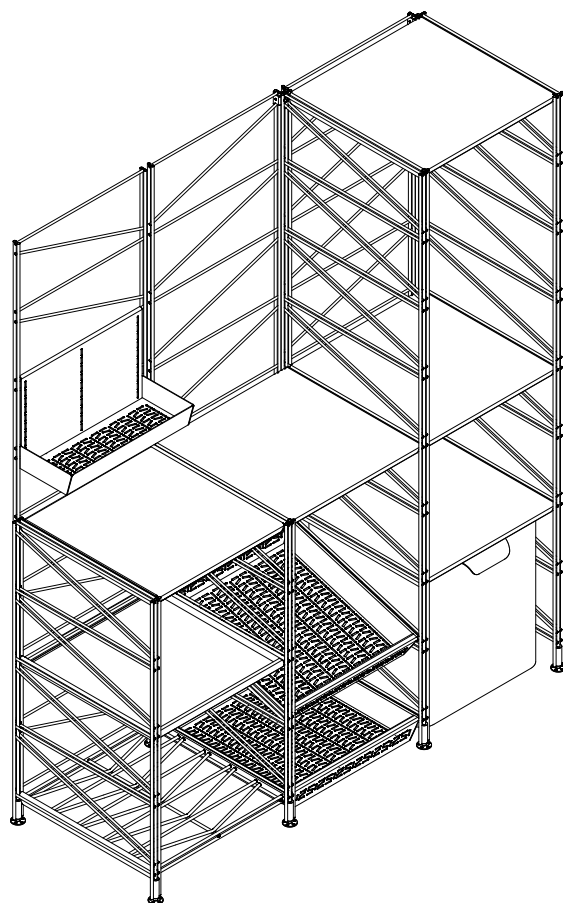

2940E		4700E	
MIN	MAX	MIN	MAX
1	2	1	1
MIN	MAX	MIN	MAX
1	1	1	1

H 160

H 83

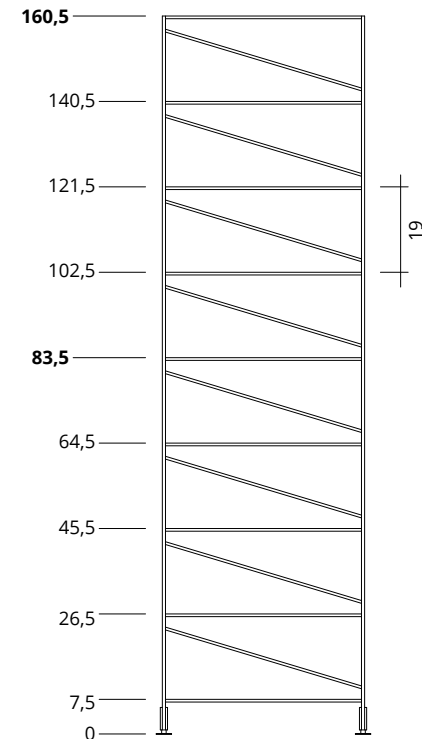

Acciaio zincato e verniciato con polveri epossidiche per esterni.
Galvanized and epoxy-powder coated steel for outdoor use.

RESISTENZA ALLA CORROSIONE
CORROSION TEST
NSS UNI EN ISO 9227:2017
Ore di esposizione / Hours of exposure
800

Fori per eventuale fissaggio a pavimento.
Holes for possible fixing to the floor.
Trous pour une fixation possible au sol.
Agujeros para posible fijación al suelo.
Löcher für mögliche befestigung am Boden.

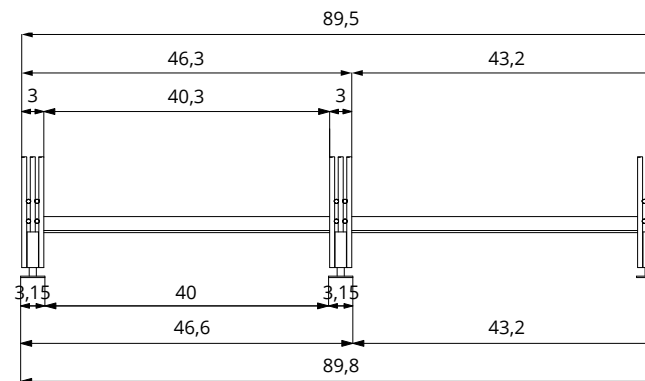

BIG

design

Marc Sadler

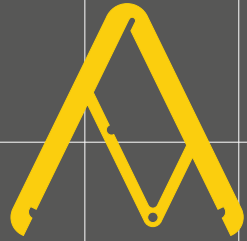

Compasso d'Oro

I Ideata quasi come un componente architettonico, Big è una libreria in metallo caratterizzata da robusti montanti in alluminio estruso con sezione a "T" e da ripiani in lamiera con bordo frontale decisamente importante, visivamente assimilabili a ripiani in muratura. Accentua questo aspetto la finitura bianco opaco, molto simile ad una muratura rasata a gesso e imbiancata. Le sue forme decise e ben delineate la rendono un "oggetto polifunzionale", in grado di caratterizzare indifferentemente ambienti moderni, hi-tech, classici o storici.

EN Conceived almost as an architectural component, Big is a metal bookcase made of sturdy extruded aluminum uprights forming a "T" section and shelves in metal sheet, presenting a visually prominent front edge that gives the appearance of masonry shelves. The matt white finish accentuates this impression as it is highly reminiscent of brickwork stripped back to plaster and whitewashed. The pronounced and well-delineated shapes make this a multifunctional object that can fit equally well into a modern, hi-tech, classic or historical environment.







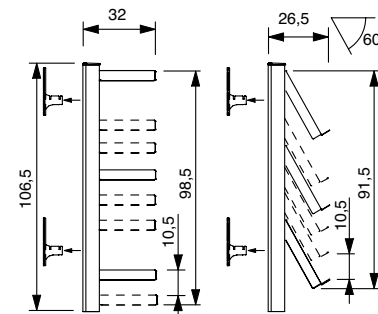
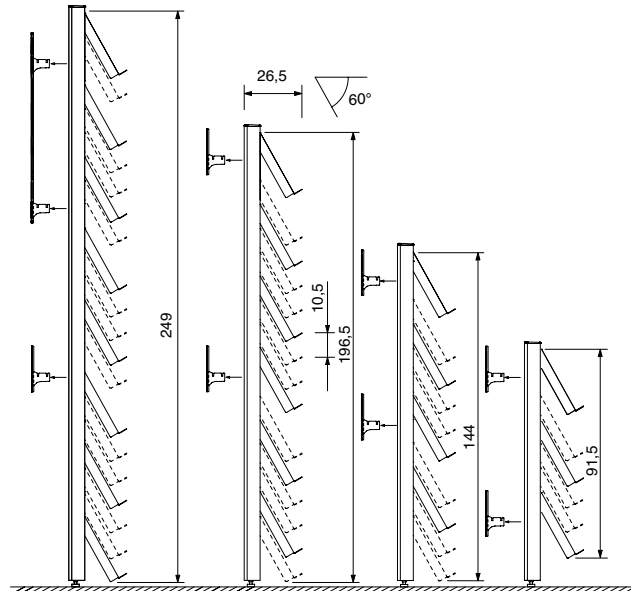
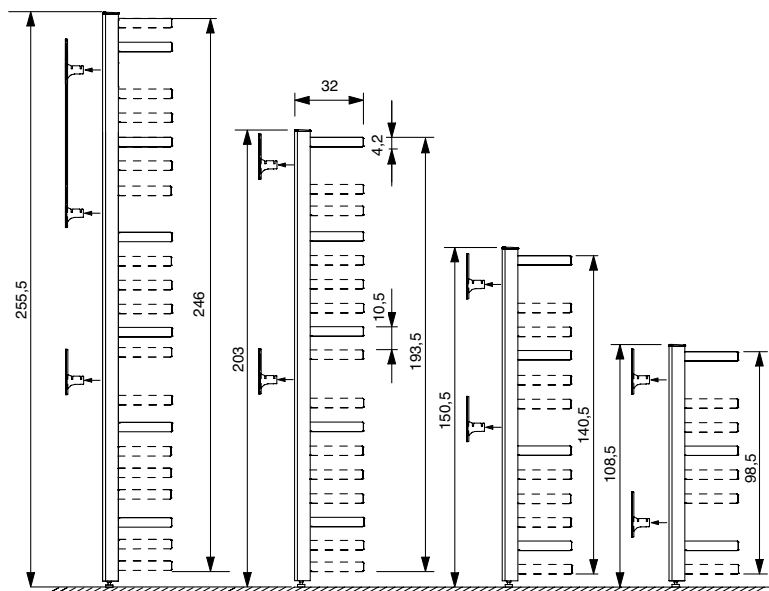
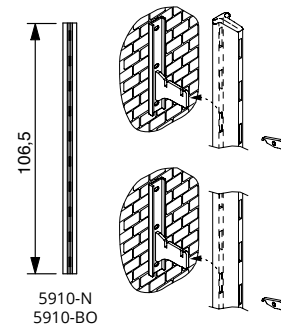
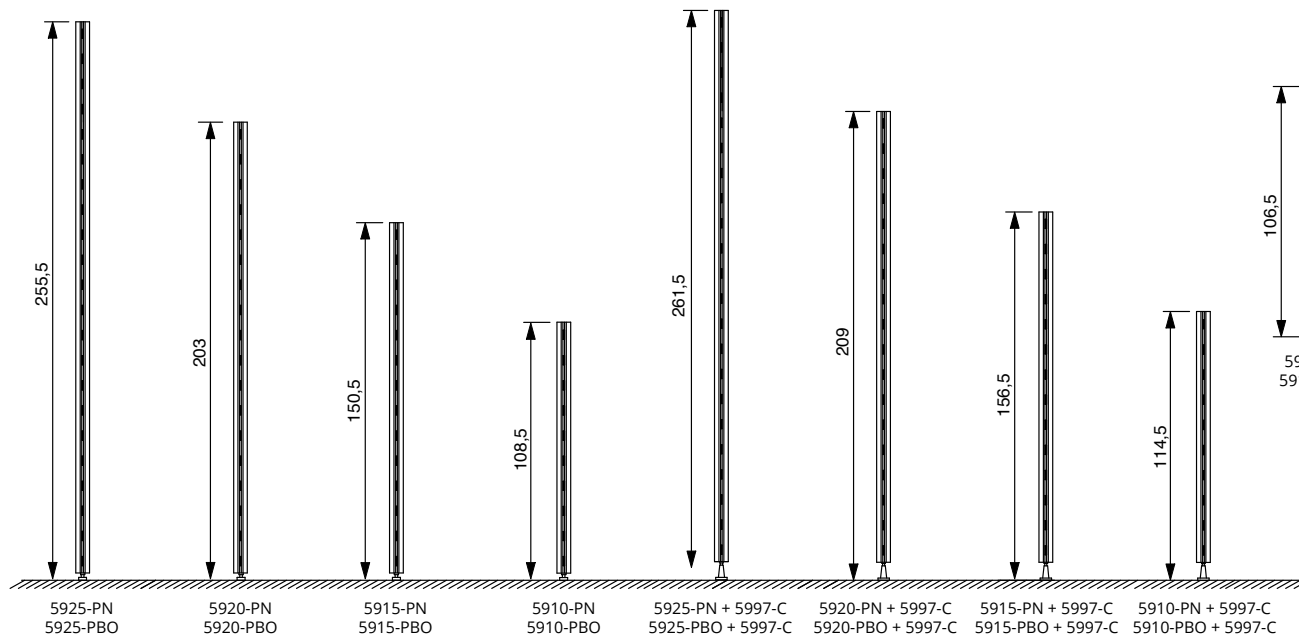
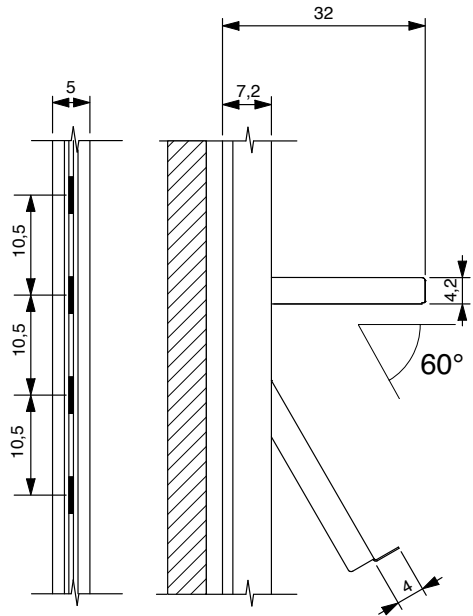

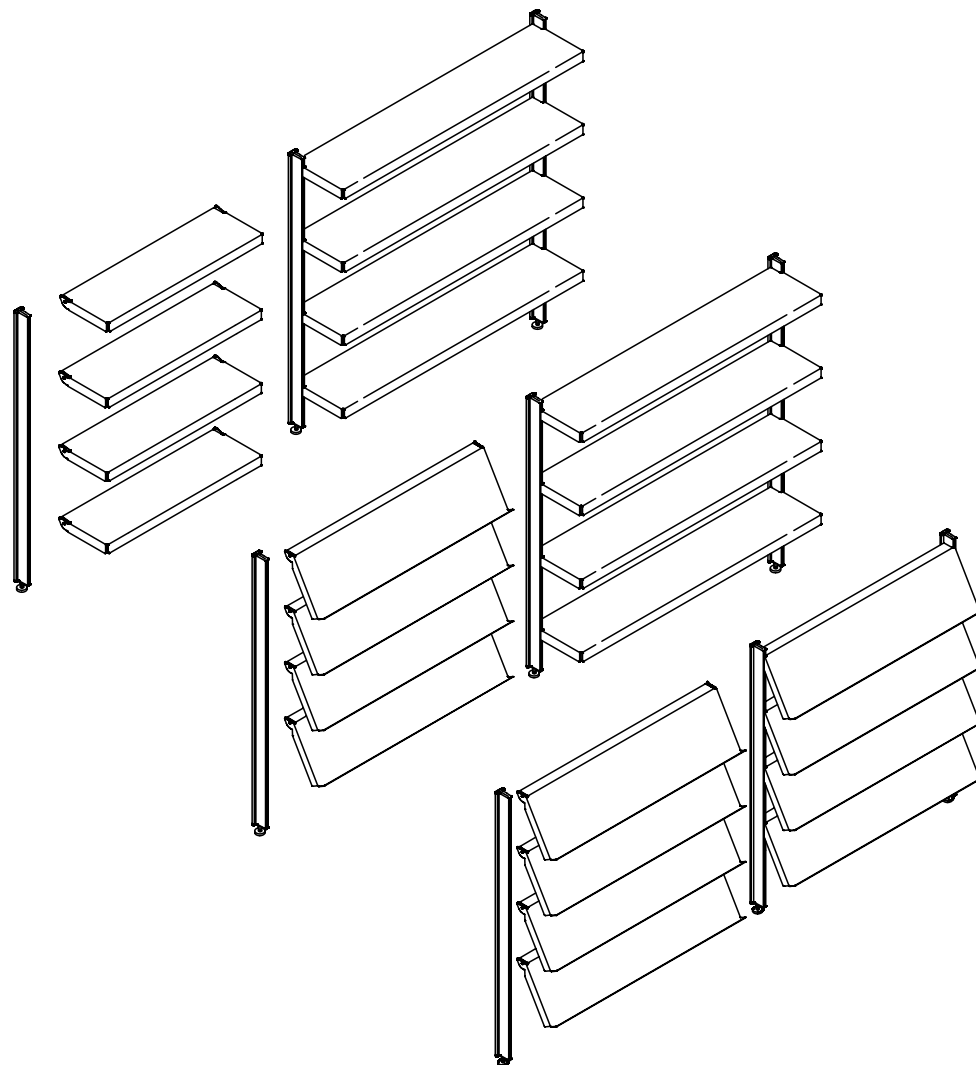
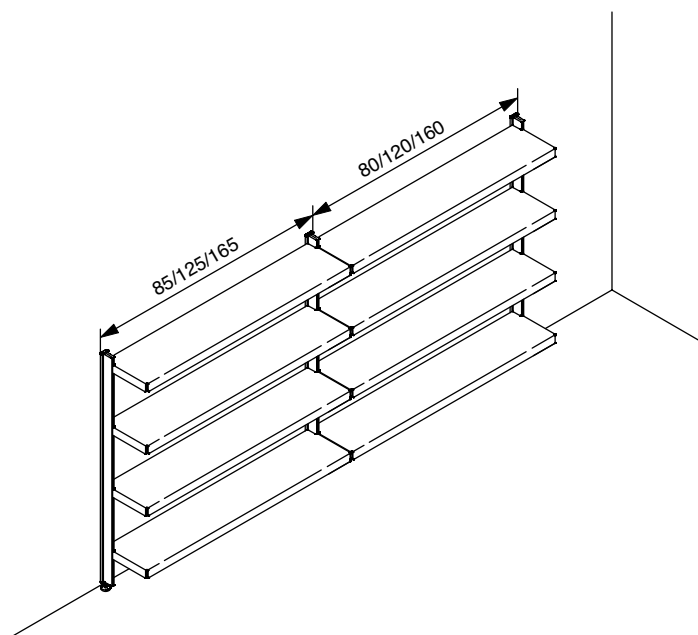
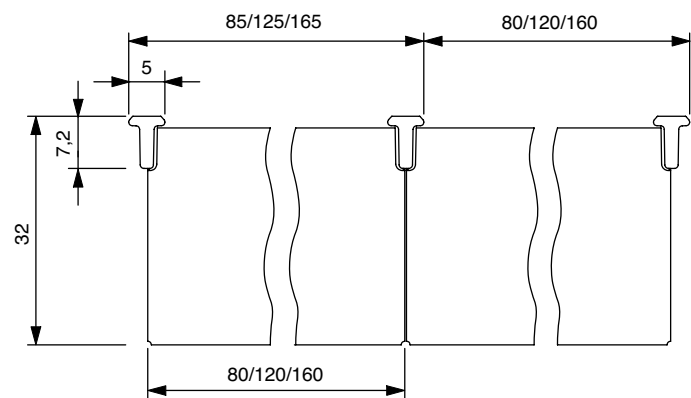

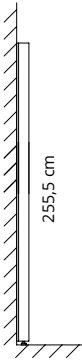
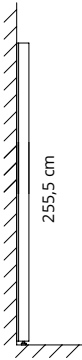
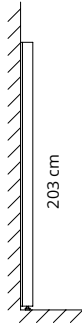
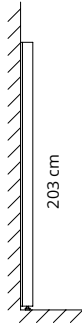





F Big est une bibliothèque en métal, conçue presque comme un élément architectural. Elle se distingue par ses montants robustes en aluminium extrudé avec profil en T et des étagères en tôle avec un rebord frontal très marqué, donnant l'idée d'étagères en maçonnerie. Cet aspect est renforcé par le finissage en blanc opaque, ressemblant beaucoup à une maçonnerie plâtrée et blanchie à la chaux. Ses formes bien définies en font un "objet polyvalent", capable de s'intégrer indifféremment dans des intérieurs modernes, hi-tech, classiques ou historiques.

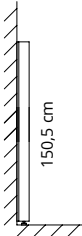
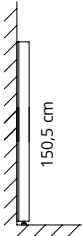
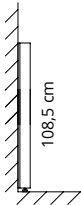
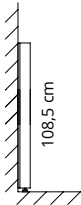



D Einem architektonischen Bauelement nachempfunden, ist Big ein Metallregal mit starken T-Querschnitt-Ständern aus stranggepresstem Aluminium und Regalböden aus Blech mit einer besonders betonten Vorderkante, deren Aussehen an Mauerwerkablagen erinnert. Dieses Aussehen wird weiter von der matt-weißen Oberflächenbehandlung hervorgehoben, die einer angemalten Gipswand stark ähnelt. Die entschlossenen, klar definierten Linien machen aus Big ein "Mehrfunktions-Objekt", das genauso gut zu modernen, Hi-Tech-Räumen wie zu klassischen Räumen mit geschichtlichem Flair passt.

E Concebida como si fuese un componente arquitectónico, Big es una librería de metal que se caracteriza por sus sólidos montantes de aluminio de extrusión con sección en "T" y por los estantes de metal con un característico borde anterior, muy parecidos a los estantes de mampostería. Acentúa este aspecto el acabado blanco opaco. Gracias a su diseño esencial y definido es un "objeto multifuncional" que logra caracterizar tanto los ambientes modernos y hi-tech como los clásicos.



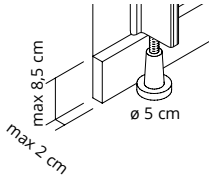
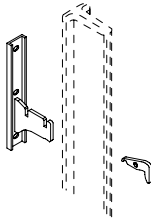

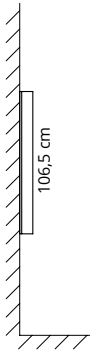





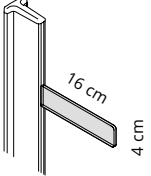

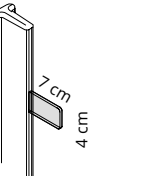

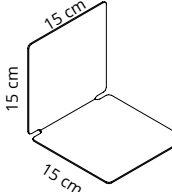

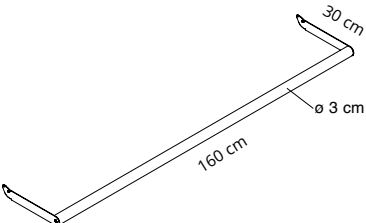
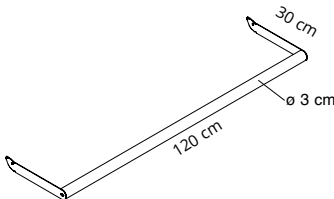
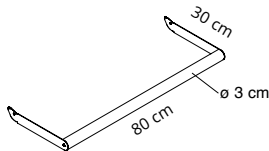

				
				
CD.	5925-PN	5925-PBO	5920-PN	5920-PBO
PR.	€ 297,00	€ 297,00	€ 278,00	€ 278,00
CL.	N	BO	N	BO
				
DS.	<p>Montante a parete in alluminio verniciato con polveri epossidiche, con appoggio a terra. Completo di staffe per fissaggio a parete. Powder-coated aluminum wall side-upright, floor bearing. Equipped with plates for wall fastening. Montant mural en aluminium peint époxy, appui au sol. Complet de platines pour fixation murale. Lateral de pared en aluminio recubierto, con apoyo al suelo. Placas para fijación mural incluidas. Wandseitenteil aus mit Epoxypulver beschichtetem Aluminium, kleiner Stützfuß, mit Wandbefestigungsbeschlägen.</p>			
				
				
CD.	5915-PN	5915-PBO	5910-PN	5910-PBO
PR.	€ 259,00	€ 259,00	€ 198,00	€ 198,00
CL.	N	BO	N	BO
				
DS.	<p>Montante a parete in alluminio verniciato con polveri epossidiche, con appoggio a terra. Completo di staffe per fissaggio a parete. Powder-coated aluminum wall side-upright, floor bearing. Equipped with plates for wall fastening. Montant mural en aluminium peint époxy, appui au sol. Complet de platines pour fixation murale. Lateral de pared en aluminio recubierto, con apoyo al suelo. Placas para fijación mural incluidas. Wandseitenteil aus mit Epoxypulver beschichtetem Aluminium, kleiner Stützfuß, mit Wandbefestigungsbeschlägen.</p>			

	<p>Opzionale Optional Optionnel Opcional Optional</p> <p>Per art. / For ref. / Pour réf. / Para ref. / Für Art. 5925-PN, 5925-PBO 5920-PN, 5920-PBO 5915-PN, 5915-PBO 5910-PN, 5910-PBO</p>  	<p>Opzionale Optional Optionnel Opcional Optional</p> 	
CD.	5997-C	5992-N	5992-BO
PR.	€ 68,00	€ 56,00 (2 pcs)	€ 56,00 (2 pcs)
CL.		N	BO
			
DS.	<p>Piede in acciaio nichelsatinato da utilizzare in presenza di battiscopa. Nickel-satin steel foot to use in case of skirting board. Pied en acier nickel-satiné à utiliser avec plinthe. Pie en acero niquel-satinado para utilizar con rodapie. Fuß aus Stahl, Endbehandlung mattiertes Nickel zur Verwendung bei Sockelleiste.</p>	<p>Staffe supplementari per fissaggio a parete. Extra plates for wall fastening. Platines supplémentaires pour fixation murale. Placas adicionales para fijación mural. Zusätzliche Beschläge zur Wandbefestigung.</p>	
			
CD.	5910-N	5910-BO	
PR.	€ 198,00	€ 198,00	
CL.	N	BO	
			
DS.	<p>Montante a parete in alluminio verniciato con polveri epossidiche. Completo di staffe per fissaggio a parete. Powder-coated aluminum wall side-upright. Equipped with plates for wall fastening. Montant mural en aluminium peint époxy. Complet de platines pour fixation murale. Lateral de pared en aluminio recubierto. Placas para fijación mural incluidas. Wandseitenteil aus mit Epoxypulver beschichtetem Aluminium, mit Wandbefestigungsbeschlägen.</p>		

<p>CD. 5936-N</p>	<p>CD. 5936-BO</p>	<p>CD. 5934-N</p>	<p>CD. 5934-BO</p>	<p>CD. 5932-N</p>	<p>CD. 5932-BO</p>
<p>PR. € 159,00</p>	<p>PR. € 159,00</p>	<p>PR. € 148,00</p>	<p>PR. € 148,00</p>	<p>PR. € 128,00</p>	<p>PR. € 128,00</p>
<p>CL. N</p>	<p>CL. BO</p>	<p>CL. N</p>	<p>CL. BO</p>	<p>CL. N</p>	<p>CL. BO</p>
<p>DS. Ripiani in acciaio verniciato con polveri epossidiche. Powder-coated steel shelves. Tablettes en acier peint en époxy. Estantes en acero recubierto con polvos epoxidicos. Regalböden aus mit Epoxypulver beschichtetem Stahl.</p>					
<p>CD. 5946-N</p>	<p>CD. 5946-BO</p>	<p>CD. 5944-N</p>	<p>CD. 5944-BO</p>	<p>CD. 5942-N</p>	<p>CD. 5942-BO</p>
<p>PR. € 168,00</p>	<p>PR. € 168,00</p>	<p>PR. € 158,00</p>	<p>PR. € 158,00</p>	<p>PR. € 138,00</p>	<p>PR. € 138,00</p>
<p>CL. N</p>	<p>CL. BO</p>	<p>CL. N</p>	<p>CL. BO</p>	<p>CL. N</p>	<p>CL. BO</p>
<p>DS. Ripiani espositori inclinati in acciaio verniciato con polveri epossidiche. Inclined display shelves in powder-coated steel. Tablettes/présentoirs inclinées en acier peint en époxy. Estantes expositores inclinados en acero recubierto con polvos epoxi. Schrägtablaure aus mit Epoxypulver beschichtetem Stahl.</p>					

	 	 	 				
CD.	5980	5981	5987-N	5987-BO			
PR.	€ 18,00 (2 pcs)	€ 17,00 (2 pcs)	€ 32,50 (2 pcs)	€ 32,50 (2 pcs)			
CL.			N	BO			
DS.	<p>Fermalibri in tecnopolimero traslucido. Translucent high-tech polymer book holder. Serre-livres en technopolymère translucide. Separadores en tecnopolimero traslucido. Buchstütze aus durchsichtigem Technopolymer.</p>		<p>Fermalibri in acciaio verniciato. Powder-coated steel book holder. Serre-livres en acier peint. Separadores en acero recubierto. Buchstütze aus pulverbeschichtetem Stahl.</p>				
							
CD.	5986-N	5986-BO	5984-N	5984-BO	5982-N	5982-BO	
PR.	€ 137,00	€ 137,00	€ 125,00	€ 125,00	€ 97,00	€ 97,00	
CL.	N	BO	N	BO	N	BO	
							
DS.	<p>Barra portabiti con supporti in acciaio verniciato con polveri epossidiche e tubo in acciaio cromato. Clothes-hanger with powder-coated supports, chrome-plated bar. Barre portemanteaux avec supports en acier peint en époxy, tige en acier chromé. Barra perchero con soportes en acero recubierto con polvos epoxidicos, barra en acero cromado. Garderobenstange aus verchromtem Stahl mit Halterungen aus pulverbeschichtetem Stahl.</p>						

TABLES

design

Sezgin Aksu

Angelotti & Cardile

Caimi Lab

Lorenzo Stano

Silvia Suardi















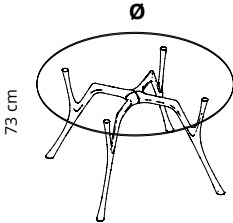









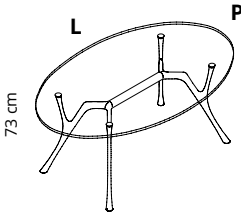







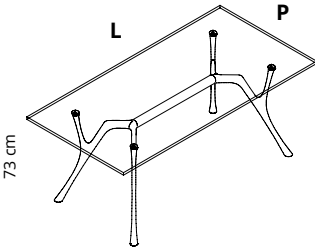

I tavoli rappresentano una scelta di carattere identificativo all'interno di ogni ambiente: arredi di primaria importanza che devono avere un design ed una qualità riconoscibili. Oggetti iconici, con piani in diversi colori e finiture, dal design essenziale e raffinato, abbinati alle sinuose ed eleganti strutture in alluminio dei tavoli Pegaso, o dei funzionali tavolini Jolly e Cicerone. Oggetti d'arredo intramontabili grazie all'attenzione al dettaglio che ne caratterizza il progetto e la produzione.

EN_The choice of tables is what gives a room its distinctive character: they are items of primary importance that must be recognizable for their design and quality. Iconic objects with tops available in several colours and with different finishes, notable for their austere yet refined design, perfectly matched with the elegantly sinuous aluminum Pegaso table frame, or, equally, the practical and functional Jolly and Cicerone coffee tables. Thanks to the attention to detail that has gone into their design and production, these items of furnishing never go out of date.

F_Le choix des chaises et tables caractérise et identifie chaque intérieur: ce sont des éléments d'ameublement qui possèdent une importance primaire et doivent se distinguer par leur design et leur qualité. Des objets iconiques, proposés en différentes couleurs et finissages, au design épuré et sophistiqué, associés aux structures sinueuses et élégantes en aluminium des tables Pegaso, ou des tables basses fonctionnelles Jolly et Cicerone. Des objets d'ameublement intemporels, grâce à l'attention portée aux détails qui en caractérisent la conception et la production.

E_Las mesas otorgan una decoración única a cada ambiente: son elementos fundamentales que deben poder identificarse por su diseño y calidad. Son objetos icónicos, con sus diferentes colores y acabados, un diseño esencial y refinado, que se acoplan a las sinuosas y elegantes estructuras de aluminio de las mesas Pegaso, o a las funcionales mesas Jolly y Cicerone. Elementos de decoración atemporales gracias a un diseño y una producción centrados en los detalles.

D_Tische sind eine erkennbare Wahl in jeder Umgebung: Möbel von primärer Bedeutung, die ein erkennbares Design und Qualität haben müssen. Ikonische Objekte mit Platten in verschiedenen Farben und Ausführungen, mit einem essentiellen und raffinierten Design, kombiniert mit den gewundenen und eleganten Aluminiumstrukturen der Pegaso-Tische oder den funktionalen Jolly- und Cicerone-Couchtischen. Einrichtungsgegenstände, die dank der Detailpflege bei Entwurf und Herstellung zeitlos werden.

Piano Tabletop  VETRO T GLASS	Colore struttura Frame color  BO  NM  AL	Tavoli piano VETRO TRASPARENTE e struttura bianco opaco (BO) o nero micaceo (NM) Tables with TRANSPARENT GLASS tabletop and mat white (BO) or micaceous black frame (NM)	Tavoli piano VETRO TRASPARENTE e struttura alluminio lucidato (AL) Tables with TRANSPARENT GLASS tabletop and polished aluminium frame (AL)																																																
		<table border="0"> <thead> <tr> <th>Ø cm</th> <th>COD.</th> <th></th> <th>COD.</th> <th></th> <th>€ - Eur</th> </tr> </thead> <tbody> <tr> <td>130</td> <td>2320-BO</td> <td></td> <td>2320-NM</td> <td></td> <td>2.560,00</td> </tr> </tbody> </table>	Ø cm	COD.		COD.		€ - Eur	130	2320-BO		2320-NM		2.560,00	<table border="0"> <thead> <tr> <th>Ø cm</th> <th>COD.</th> <th></th> <th>€ - Eur</th> </tr> </thead> <tbody> <tr> <td>130</td> <td>2320-AL</td> <td></td> <td>2.860,00</td> </tr> </tbody> </table>	Ø cm	COD.		€ - Eur	130	2320-AL		2.860,00																												
Ø cm	COD.		COD.		€ - Eur																																														
130	2320-BO		2320-NM		2.560,00																																														
Ø cm	COD.		€ - Eur																																																
130	2320-AL		2.860,00																																																
		<table border="0"> <thead> <tr> <th>L cm</th> <th>P cm</th> <th>COD.</th> <th></th> <th>COD.</th> <th></th> <th>€ - Eur</th> </tr> </thead> <tbody> <tr> <td>180</td> <td>110</td> <td>2322-BO</td> <td></td> <td>2322-NM</td> <td></td> <td>2.870,00</td> </tr> <tr> <td>220</td> <td>120</td> <td>2324-BO</td> <td></td> <td>2324-NM</td> <td></td> <td>3.380,00</td> </tr> </tbody> </table>	L cm	P cm	COD.		COD.		€ - Eur	180	110	2322-BO		2322-NM		2.870,00	220	120	2324-BO		2324-NM		3.380,00	<table border="0"> <thead> <tr> <th>L cm</th> <th>P cm</th> <th>COD.</th> <th></th> <th>€ - Eur</th> </tr> </thead> <tbody> <tr> <td>180</td> <td>110</td> <td>2322-AL</td> <td></td> <td>3.080,00</td> </tr> <tr> <td>220</td> <td>120</td> <td>2324-AL</td> <td></td> <td>3.690,00</td> </tr> </tbody> </table>	L cm	P cm	COD.		€ - Eur	180	110	2322-AL		3.080,00	220	120	2324-AL		3.690,00												
L cm	P cm	COD.		COD.		€ - Eur																																													
180	110	2322-BO		2322-NM		2.870,00																																													
220	120	2324-BO		2324-NM		3.380,00																																													
L cm	P cm	COD.		€ - Eur																																															
180	110	2322-AL		3.080,00																																															
220	120	2324-AL		3.690,00																																															
		<table border="0"> <thead> <tr> <th>L cm</th> <th>P cm</th> <th>COD.</th> <th></th> <th>COD.</th> <th></th> <th>€ - Eur</th> </tr> </thead> <tbody> <tr> <td>160</td> <td>90</td> <td>2310-BO</td> <td></td> <td>2310-NM</td> <td></td> <td>2.460,00</td> </tr> <tr> <td>180</td> <td>90</td> <td>2312-BO</td> <td></td> <td>2312-NM</td> <td></td> <td>2.670,00</td> </tr> <tr> <td>200</td> <td>90</td> <td>2314-BO</td> <td></td> <td>2314-NM</td> <td></td> <td>2.760,00</td> </tr> </tbody> </table>	L cm	P cm	COD.		COD.		€ - Eur	160	90	2310-BO		2310-NM		2.460,00	180	90	2312-BO		2312-NM		2.670,00	200	90	2314-BO		2314-NM		2.760,00	<table border="0"> <thead> <tr> <th>L cm</th> <th>P cm</th> <th>COD.</th> <th></th> <th>€ - Eur</th> </tr> </thead> <tbody> <tr> <td>160</td> <td>90</td> <td>2310-AL</td> <td></td> <td>2.760,00</td> </tr> <tr> <td>180</td> <td>90</td> <td>2312-AL</td> <td></td> <td>2.980,00</td> </tr> <tr> <td>200</td> <td>90</td> <td>2314-AL</td> <td></td> <td>3.070,00</td> </tr> </tbody> </table>	L cm	P cm	COD.		€ - Eur	160	90	2310-AL		2.760,00	180	90	2312-AL		2.980,00	200	90	2314-AL		3.070,00
L cm	P cm	COD.		COD.		€ - Eur																																													
160	90	2310-BO		2310-NM		2.460,00																																													
180	90	2312-BO		2312-NM		2.670,00																																													
200	90	2314-BO		2314-NM		2.760,00																																													
L cm	P cm	COD.		€ - Eur																																															
160	90	2310-AL		2.760,00																																															
180	90	2312-AL		2.980,00																																															
200	90	2314-AL		3.070,00																																															

Colore struttura
Frame color



NM
Nero micaceo.
Micaceous black.
Noir micacé.
Negro micáceo.
Schwarz glimmerhaltig.



BO
Bianco opaco.
Mat white.
Blanc opaque.
Blanco mate.
Mattweiss.



AL
Alluminio lucidato.
Polished aluminium.
Aluminium poli.
Aluminio brillante.
Poliertes Aluminium.

Tavoli con struttura in fusione di alluminio lucidato o verniciato. Piano in vetro temperato e molato trasparente spessore 12 mm.
Tables with polished or powder-coated die-cast aluminum frame. Transparent tempered and ground glass desk-top, thickness 12 mm.
Tables avec structure en aluminium moulé sous pression, poli ou peint. Dessus en verre trempé et biseauté, transparent, épaisseur 12 mm.
Mesas con estructura en aluminio a presión, pulido o barnizado. Plano en vidrio templado biselado transparente espesor 12 mm.
Tisch mit Untergestell aus druckgegossenem Aluminium, poliert oder mit Epoxypulver beschichtet. Tischplatte aus gehärtetem Sicherheitsglas, transparent, Stärke 12 mm



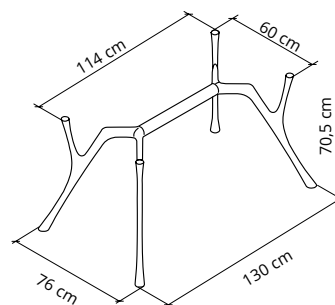
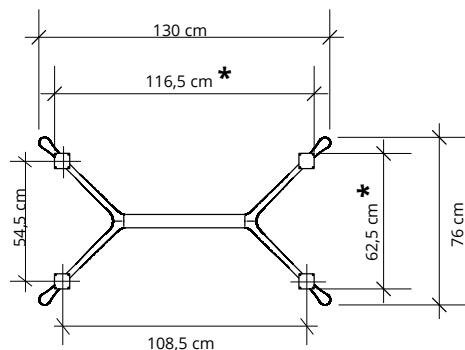

CD.	S2304-NM	S2304-BO	S2304-AL
PR.	€ 1.310,00	€ 1.310,00	€ 1.620,00
CL.	NM	BO	AL

DS. **Struttura in fusione di alluminio lucidato o verniciato per tavoli, attacchi al piano esclusi:**
Polished or powder-coated die-cast aluminum frame for tables, top fixing plates not included:
Structure en aluminium moulé sous pression, poli ou peint pour tables, platines de fixation pour plateau pas incluses:
Estructura en aluminio a presión, brillante o barnizado para mesas, ataques al plano excluidos:
Tischgestell aus druckgegossenem Aluminium, poliert oder pulverbeschichtet, Tischplattenbefestigung nicht inbegriffen :
cod. 2310-NM, 2310-BO, 2310-AL
cod. 2322-NM, 2322-BO, 2322-AL

*Dimensioni riferite a strutture con piastra cod. **A120** - *Dimensions refer to systems with plate code **A120** - *Dimensions référées à structures avec platine réf. **A120** -
 *Dimensiones referentes a las estructuras con placa cod. **A120** - *Abmessungen beziehen sich auf Untergestell mit Tischplatte Art. **A120**



NM
 Nero micaceo.
 Micaceous black
 Noir micacé.
 Negro micáceo.
 Schwarz glimmerhalt g.



BO
 Bianco opaco.
 Mat white.
 Blanc opaque.
 Blanco mate.
 Mattweiss.

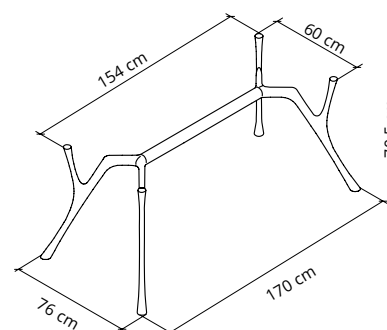
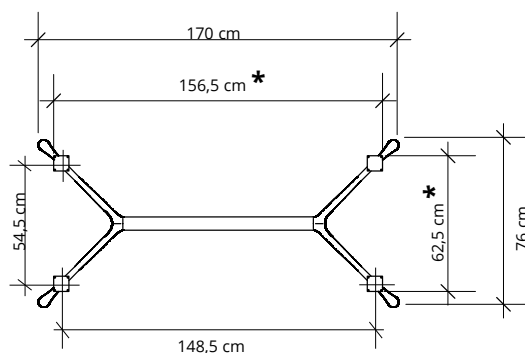

CD.	S2306-NM	S2306-BO	S2306-AL
PR.	€ 1.330,00	€ 1.330,00	€ 1.640,00
CL.	NM	BO	AL

DS. **Struttura in fusione di alluminio lucidato o verniciato per tavoli, attacchi al piano esclusi:**
Polished or powder-coated die-cast aluminum frame for tables, top fixing plates not included:
Structure en aluminium moulé sous pression, poli ou peint pour tables, platines de fixation pour plateau pas incluses:
Estructura en aluminio a presión, brillante o barnizado para mesas, ataques al plano excluidos:
Tischgestell aus druckgegossenem Aluminium, poliert oder pulverbeschichtet, Tischplattenbefestigung nicht inbegriffen :
cod. 2312-NM, 2312-BO, 2312-AL
cod. 2314-NM, 2314-BO, 2314-AL
cod. 2324-NM, 2324-BO, 2324-AL

*Dimensioni riferite a strutture con piastra cod. **A120** - *Dimensions refer to systems with plate code **A120** - *Dimensions référées à structures avec platine réf. **A120** -
 *Dimensiones referentes a las estructuras con placa cod. **A120** - *Abmessungen beziehen sich auf Untergestell mit Tischplatte Art. **A120**



AL
 Alluminio lucidato.
 Polished aluminum.
 Aluminium poli.
 Aluminio brillante.
 Poliertes Aluminium.

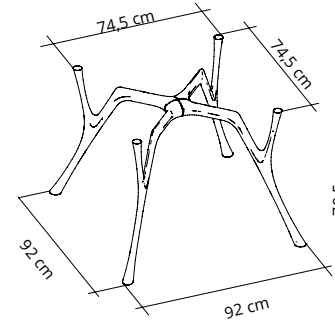
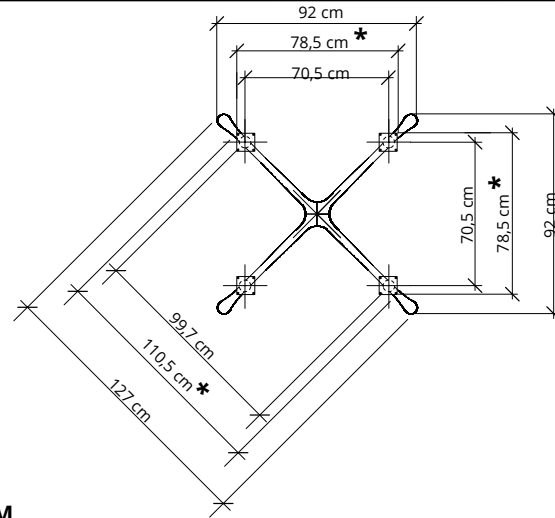

CD.	S2302-NM	S2302-BO	S2302-AL
PR.	€ 1.230,00	€ 1.230,00	€ 1.540,00
CL.	NM	BO	AL

Struttura in fusione di alluminio lucidato o verniciato per tavoli, attacchi al piano esclusi:
 Polished or powder-coated die-cast aluminium frame for tables, top fixing plates not included:
 Structure en aluminium moulé sous pression, poli ou peint pour tables, platines de fixation pour plateau pas incluses:
 Estructura en aluminio a presión, brillante o barnizado para mesas, ataques al plano excluidos:
 Tischgestell aus druckgegossenem Aluminium, poliert oder pulverbeschichtet, Tischplattenbefestigung nicht inbegriffen:
cod. 2320-NM, 2320-BO, 2320-AL

*Dimensioni riferite a strutture con piastra cod. **A120** - *Dimensions refer to systems with plate code **A120** - *Dimensions référées à structures avec platine réf. **A120** -
 *Dimensiones referentes a las estructuras con placa cod. **A120** - *Abmessungen beziehen sich auf Untergestell mit Tischplatte Art. **A120**

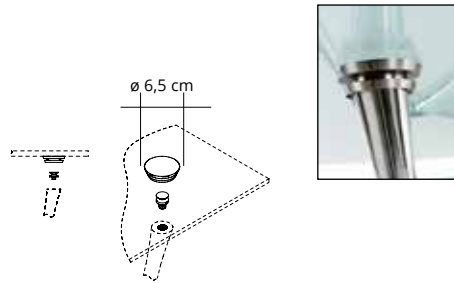

2352

€ 140,00 (4 pcs)

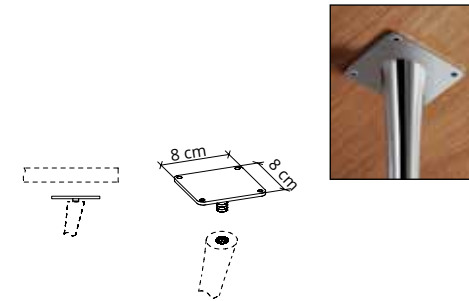

A120

€ 50,00 (4 pcs)

CD.		
PR.		
CL.		
DS.	<p>Piastre in acciaio inox per incollaggio piani in vetro. Stainless steel plates to be glued to glass desk-top. Platines en acier inox à fixer au plateau en verre. Placas en acero inoxidable para pegamiento planos en vidrio. Montageplatten aus rostfreiem Stahl für Glastischplatten.</p>	<p>Piastre in acciaio per fissaggio piani in legno. Steel plates to fix wooden desk-top. Platines en acier pour fixation des plateaux en bois. Placas en acero para fijar los planos en madera. Montageplatten aus Stahl für Holztischplatten.</p>

Design rigoroso per il tavolo Pegaso, studiato per raggiungere anche dimensioni importanti e proposto con piano in composito estremamente leggero con struttura a “sandwich” costituito da un’anima in legno listellare, racchiuso tra due lastre di alluminio rivestite nella parte superiore e sui bordi perimetrali in cemento o in resina metallica finitura bronzo fuso, in cui il carattere artigianale della lavorazione rende ogni pezzo unico ed esclusivo. Alla semplicità e pulizia formale del piano si contrappongono le forme sinuose della struttura, realizzata in alluminio lucido o verniciato con polveri epossidiche.

The Pegaso table has been rigorously designed to allow it to be produced in significant sizes. It features an exceptionally lightweight composite tabletop with a “sandwich” structure, consisting of a blockboard core between two aluminium panels. The top and edges of these panels are finished in concrete or a metallic resin with a cast bronze finish, such that the handcrafted character makes each piece unique and exclusive. The simplicity and formal clarity of the top contrasts with the sinuous shapes of the supporting structure in polished or epoxy powder-coated aluminium.

Pegaso est une table au design rigoureux, conçue pour être déclinée également en grandes dimensions; elle est proposée avec un plateau en matériau composite extrêmement léger avec une structure en « sandwich » formée par un cœur en bois latté, contenu entre deux feuilles en aluminium, recouvertes sur la partie supérieure et sur les bords en ciment ou en résine métallique finissage en bronze fondu, dont le caractère artisanal de la fabrication rend chaque pièce unique et exclusive. La simplicité et la netteté formelle du plateau font un beau contraste avec les formes sinueuses de la structure, fabriquée en aluminium poli ou peint à la peinture époxy.

La mesa Pegaso se caracteriza por un diseño riguroso, estudiado para alcanzar dimensiones significativas, que se propone con un tablero en madera compuesta extremadamente ligero gracias a la estructura de tipo “sandwich”, formada por madera listonada recubierta a ambos lados por placas de aluminio revestidas en la parte superior y bordes perimetrales en cemento o resina metálica con acabado en bronce fundido, cuya elaboración artesanal aporta un carácter único y exclusivo a cada pieza. Las líneas limpias y sencillas del tablero contrastan con las formas sinuosas de la estructura, elaborada en aluminio brillante o barnizado con polvo epoxi.

Ein rigoroses Design für den Tisch Pegaso, der dazu konzipiert ist, auch für große Dimensionen anzunehmen. Seine extrem leichte Verbundplatte mit „Sandwich“-Struktur besteht aus einer Mittellage aus Holz zwischen zwei Aluminiumplatten, die an der Oberseite und an den Umfangskanten mit Zement oder Metallharz mit Bronzeguss-Finish überzogen sind, wodurch die handwerkliche Einzigartigkeit jedes exklusiven Stücks voll zur Geltung kommt. Die Schlichtheit und formale Nüchternheit der Tischplatte steht im Kontrast zu den geschwungenen Formen des Gestells aus Aluminium, glänzend oder mit Epoxidpulver-Beschichtung.

Alluminio
Aluminium
Aluminium
Aluminio
Aluminium

Lastra di legno
Wooden plate
Plaque de bois
Placa de madera
Holplatte

Alluminio
Aluminium
Aluminium
Aluminio
Aluminium

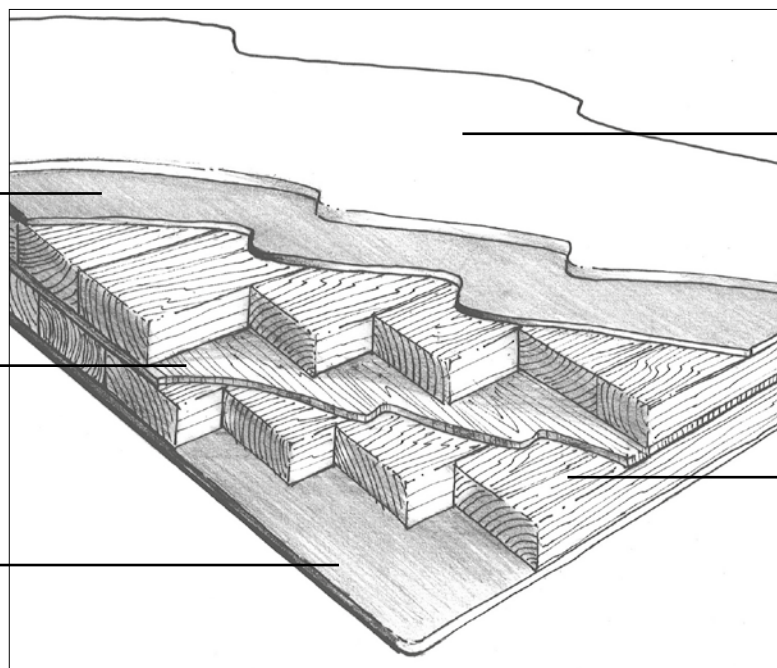

Cemento / Finitura bronzo fuso
Cement / Molten bronze finish
Béton / Finition bronze fondu
Hormigón / Finición bronce fundido
Zement / Bronzeguss-Optik

Legno listellare
Plywood
Contreplaqué latté
Láminas de madera
Sperrholzkern



Clicca e guarda
il video.

Click and watch
the video.

**Watch the top
manufacturing
process**



Design rigoroso per il tavolo Pegaso, studiato per raggiungere anche dimensioni importanti e proposto con piano in composito estremamente leggero con struttura a "sandwich" costituito da un'anima in legno listellare, racchiuso tra due lastre di alluminio rivestite nella parte superiore e sui bordi perimetrali con un foglio di resina acrilica bianca spazzolata oppure impiallaciato rovere chiaro, rovere nero o noce canaletto. Alla semplicità e pulizia formale del piano si contrappongono le forme sinuose della struttura, realizzata in alluminio lucido o verniciato con polveri epossidiche.

The Pegaso table has been rigorously designed to allow it to be produced in significant sizes. It features an exceptionally lightweight composite tabletop with a "sandwich" structure, consisting of a blockboard core between two aluminium panels. The top and edges of these panels are finished in brushed white acrylic resin or veneered in light oak, black oak or American walnut. The simplicity and formal clarity of the top contrasts with the sinuous shapes of the supporting structure in polished or epoxy powder-coated aluminium.

Pegaso est une table au design rigoureux, conçue pour être déclinée également en grandes dimensions; elle est proposée avec un plateau en matériau composite extrêmement léger avec une structure en « sandwich » formée par un cœur en bois aggloméré, contenu entre deux feuilles en aluminium recouvertes sur la partie supérieure et sur les bords d'une feuille en résine acrylique blanche brossée ou plaquée en chêne clair, en chêne noir ou en noyer canaletto. La simplicité et la netteté formelle du plateau font un beau contraste avec les formes sinueuses de la structure, fabriquée en aluminium poli ou peint à la peinture époxy.

La mesa Pegaso se caracteriza por un diseño riguroso, estudiado para alcanzar dimensiones significativas, que se propone con un tablero en madera compuesta extremadamente ligero gracias a la estructura de tipo "sandwich", formada por madera listonada recubierta a ambos lados por placas de aluminio revestidas en la parte superior y bordes perimetrales por una lámina de resina acrílica blanca cepillada o enchapado en roble claro, roble negro o nogal canaletto. Las líneas limpias y sencillas del tablero contrastan con las formas sinuosas de la estructura, elaborada en aluminio brillante o barnizado con polvo epoxi.

Ein rigoroses Design für den Tisch Pegaso, der dazu konzipiert ist, auch für große Dimensionen anzunehmen. Seine extrem leichte Verbundplatte mit „Sandwich“-Struktur besteht aus einer Mittellage aus Holz zwischen zwei Aluminiumplatten, die an der Oberseite und an den Umfangskanten mit einer Schicht aus gebürstetem weißem Acrylharz oder mit einem Furnier aus heller Eiche, schwarzer Eiche oder Nussbaum Canaletto verkleidet sind. Die Schlichtheit und formale Nüchternheit der Tischplatte steht im Kontrast zu den geschwungenen Formen des Gestells aus Aluminium, glänzend oder mit Epoxidpulver-Beschichtung.

Alluminio
Aluminium
Aluminium
Aluminio
Aluminium





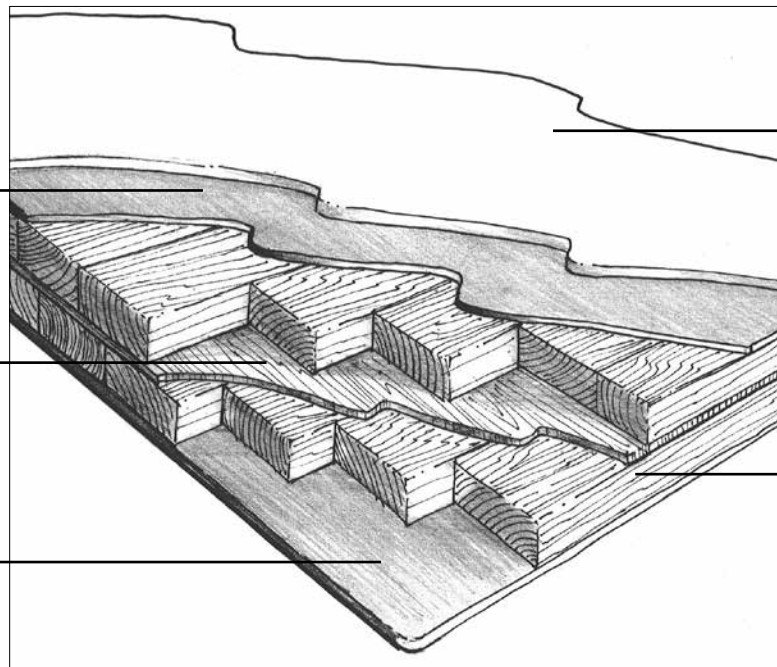









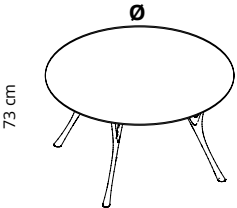









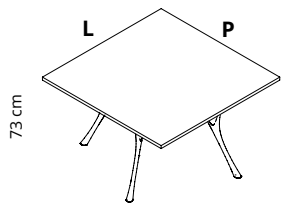







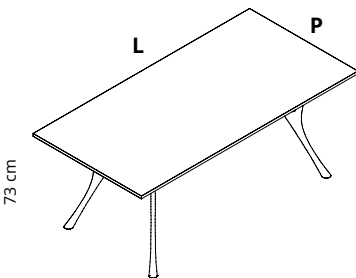

Lastra di legno
Wooden plate
Plaque de bois
Placa de madera
Holplatte

Alluminio
Aluminium
Aluminium
Aluminio
Aluminium



Resina acrilica bianca / Finitura rovere - Noce canaletto
White brushed acrylic / Oak - Canaletto walnut finish
Résine acrylique blanche / Finition bois de chêne - Noyer Canaletto
Resina acrílica blanca / Finiton madera de roble - nogal Canaletto
Weißem gebürstetem Acrylharz / Eichenholz - Canaletto-Nussbaum
Optik

Legno listellare
Plywood
Contreplaqué latté
Láminas de madera
Sperrholzkern

Piano Tabletop  SOLID Colore struttura Frame color  BO  NM  AL	Tavoli piano SOLID e struttura bianco opaco (BO) o nero micaceo (NM) Tables with SOLID tabletop and mat white (BO) or micaceous black frame (NM)	Tavoli piano SOLID e struttura alluminio lucidato (AL) Tables with SOLID tabletop and polished aluminium frame (AL)																																																																																																																																																																																																																																				
	<table border="1"> <thead> <tr> <th>Ø cm</th> <th>COD.</th> <th> BO</th> <th>COD.</th> <th> NM</th> <th>€ - Eur</th> </tr> </thead> <tbody> <tr> <td>130</td> <td>2PST130-BO</td> <td></td> <td>2PST130-NM</td> <td></td> <td>2.870,00</td> </tr> <tr> <td>150</td> <td>2PST150-BO</td> <td></td> <td>2PST150-NM</td> <td></td> <td>3.190,00</td> </tr> </tbody> </table>	Ø cm	COD.	 BO	COD.	 NM	€ - Eur	130	2PST130-BO		2PST130-NM		2.870,00	150	2PST150-BO		2PST150-NM		3.190,00	<table border="1"> <thead> <tr> <th>Ø cm</th> <th>COD.</th> <th> AL</th> <th>€ - Eur</th> </tr> </thead> <tbody> <tr> <td>130</td> <td>2PST130-AL</td> <td></td> <td>3.170,00</td> </tr> <tr> <td>150</td> <td>2PST150-AL</td> <td></td> <td>3.490,00</td> </tr> </tbody> </table>	Ø cm	COD.	 AL	€ - Eur	130	2PST130-AL		3.170,00	150	2PST150-AL		3.490,00																																																																																																																																																																																																						
Ø cm	COD.	 BO	COD.	 NM	€ - Eur																																																																																																																																																																																																																																	
130	2PST130-BO		2PST130-NM		2.870,00																																																																																																																																																																																																																																	
150	2PST150-BO		2PST150-NM		3.190,00																																																																																																																																																																																																																																	
Ø cm	COD.	 AL	€ - Eur																																																																																																																																																																																																																																			
130	2PST130-AL		3.170,00																																																																																																																																																																																																																																			
150	2PST150-AL		3.490,00																																																																																																																																																																																																																																			
	<table border="1"> <thead> <tr> <th>L cm</th> <th>P cm</th> <th>COD.</th> <th> BO</th> <th>COD.</th> <th> NM</th> <th>€ - Eur</th> </tr> </thead> <tbody> <tr> <td>140</td> <td>140</td> <td>2PSQ140140-BO</td> <td></td> <td>2PSQ140140-NM</td> <td></td> <td>3.130,00</td> </tr> </tbody> </table>	L cm	P cm	COD.	 BO	COD.	 NM	€ - Eur	140	140	2PSQ140140-BO		2PSQ140140-NM		3.130,00	<table border="1"> <thead> <tr> <th>L cm</th> <th>P cm</th> <th>COD.</th> <th> AL</th> <th>€ - Eur</th> </tr> </thead> <tbody> <tr> <td>140</td> <td>140</td> <td>2PSQ140140-AL</td> <td></td> <td>3.430,00</td> </tr> </tbody> </table>	L cm	P cm	COD.	 AL	€ - Eur	140	140	2PSQ140140-AL		3.430,00																																																																																																																																																																																																												
L cm	P cm	COD.	 BO	COD.	 NM	€ - Eur																																																																																																																																																																																																																																
140	140	2PSQ140140-BO		2PSQ140140-NM		3.130,00																																																																																																																																																																																																																																
L cm	P cm	COD.	 AL	€ - Eur																																																																																																																																																																																																																																		
140	140	2PSQ140140-AL		3.430,00																																																																																																																																																																																																																																		
	<table border="1"> <thead> <tr> <th>L cm</th> <th>P cm</th> <th>COD.</th> <th> BO</th> <th>COD.</th> <th> NM</th> <th>€ - Eur</th> </tr> </thead> <tbody> <tr><td>160</td><td>90</td><td>2PSR16090-BO</td><td></td><td>2PSR16090-NM</td><td></td><td>2.660,00</td></tr> <tr><td>180</td><td>90</td><td>2PSR18090-BO</td><td></td><td>2PSR18090-NM</td><td></td><td>2.870,00</td></tr> <tr><td>200</td><td>90</td><td>2PSR20090-BO</td><td></td><td>2PSR20090-NM</td><td></td><td>3.180,00</td></tr> <tr><td>220</td><td>90</td><td>2PSR22090-BO</td><td></td><td>2PSR22090-NM</td><td></td><td>3.480,00</td></tr> <tr><td>240</td><td>90</td><td>2PSR24090-BO</td><td></td><td>2PSR24090-NM</td><td></td><td>3.570,00</td></tr> <tr><td>200</td><td>100</td><td>2PSR200100-BO</td><td></td><td>2PSR200100-NM</td><td></td><td>3.270,00</td></tr> <tr><td>220</td><td>100</td><td>2PSR220100-BO</td><td></td><td>2PSR220100-NM</td><td></td><td>3.570,00</td></tr> <tr><td>240</td><td>100</td><td>2PSR240100-BO</td><td></td><td>2PSR240100-NM</td><td></td><td>3.740,00</td></tr> <tr><td>260</td><td>100</td><td>2PSR260100-BO</td><td></td><td>2PSR260100-NM</td><td></td><td>4.080,00</td></tr> <tr><td>280</td><td>100</td><td>2PSR280100-BO</td><td></td><td>2PSR280100-NM</td><td></td><td>4.370,00</td></tr> <tr><td>300</td><td>100</td><td>2PSR300100-BO</td><td></td><td>2PSR300100-NM</td><td></td><td>4.550,00</td></tr> <tr><td>240</td><td>120</td><td>2PSR240120-BO</td><td></td><td>2PSR240120-NM</td><td></td><td>3.860,00</td></tr> <tr><td>260</td><td>120</td><td>2PSR260120-BO</td><td></td><td>2PSR260120-NM</td><td></td><td>4.400,00</td></tr> <tr><td>280</td><td>120</td><td>2PSR280120-BO</td><td></td><td>2PSR280120-NM</td><td></td><td>4.680,00</td></tr> <tr><td>300</td><td>120</td><td>2PSR300120-BO</td><td></td><td>2PSR300120-NM</td><td></td><td>4.800,00</td></tr> <tr><td>320</td><td>120</td><td>2PSR320120-BO</td><td></td><td>2PSR320120-NM</td><td></td><td>5.030,00</td></tr> <tr><td>340</td><td>120</td><td>2PSR340120-BO</td><td></td><td>2PSR340120-NM</td><td></td><td>5.260,00</td></tr> <tr><td>360</td><td>120</td><td>2PSR360120-BO</td><td></td><td>2PSR360120-NM</td><td></td><td>5.500,00</td></tr> </tbody> </table>	L cm	P cm	COD.	 BO	COD.	 NM	€ - Eur	160	90	2PSR16090-BO		2PSR16090-NM		2.660,00	180	90	2PSR18090-BO		2PSR18090-NM		2.870,00	200	90	2PSR20090-BO		2PSR20090-NM		3.180,00	220	90	2PSR22090-BO		2PSR22090-NM		3.480,00	240	90	2PSR24090-BO		2PSR24090-NM		3.570,00	200	100	2PSR200100-BO		2PSR200100-NM		3.270,00	220	100	2PSR220100-BO		2PSR220100-NM		3.570,00	240	100	2PSR240100-BO		2PSR240100-NM		3.740,00	260	100	2PSR260100-BO		2PSR260100-NM		4.080,00	280	100	2PSR280100-BO		2PSR280100-NM		4.370,00	300	100	2PSR300100-BO		2PSR300100-NM		4.550,00	240	120	2PSR240120-BO		2PSR240120-NM		3.860,00	260	120	2PSR260120-BO		2PSR260120-NM		4.400,00	280	120	2PSR280120-BO		2PSR280120-NM		4.680,00	300	120	2PSR300120-BO		2PSR300120-NM		4.800,00	320	120	2PSR320120-BO		2PSR320120-NM		5.030,00	340	120	2PSR340120-BO		2PSR340120-NM		5.260,00	360	120	2PSR360120-BO		2PSR360120-NM		5.500,00	<table border="1"> <thead> <tr> <th>L cm</th> <th>P cm</th> <th>COD.</th> <th> AL</th> <th>€ - Eur</th> </tr> </thead> <tbody> <tr><td>160</td><td>90</td><td>2PSR16090-AL</td><td></td><td>2.970,00</td></tr> <tr><td>180</td><td>90</td><td>2PSR18090-AL</td><td></td><td>3.180,00</td></tr> <tr><td>200</td><td>90</td><td>2PSR20090-AL</td><td></td><td>3.490,00</td></tr> <tr><td>220</td><td>90</td><td>2PSR22090-AL</td><td></td><td>3.920,00</td></tr> <tr><td>240</td><td>90</td><td>2PSR24090-AL</td><td></td><td>4.010,00</td></tr> <tr><td>200</td><td>100</td><td>2PSR200100-AL</td><td></td><td>3.580,00</td></tr> <tr><td>220</td><td>100</td><td>2PSR220100-AL</td><td></td><td>4.010,00</td></tr> <tr><td>240</td><td>100</td><td>2PSR240100-AL</td><td></td><td>4.180,00</td></tr> <tr><td>260</td><td>100</td><td>2PSR260100-AL</td><td></td><td>4.520,00</td></tr> <tr><td>280</td><td>100</td><td>2PSR280100-AL</td><td></td><td>4.810,00</td></tr> <tr><td>300</td><td>100</td><td>2PSR300100-AL</td><td></td><td>4.990,00</td></tr> <tr><td>240</td><td>120</td><td>2PSR240120-AL</td><td></td><td>4.320,00</td></tr> <tr><td>260</td><td>120</td><td>2PSR260120-AL</td><td></td><td>4.840,00</td></tr> <tr><td>280</td><td>120</td><td>2PSR280120-AL</td><td></td><td>5.120,00</td></tr> <tr><td>300</td><td>120</td><td>2PSR300120-AL</td><td></td><td>5.240,00</td></tr> <tr><td>320</td><td>120</td><td>2PSR320120-AL</td><td></td><td>5.470,00</td></tr> <tr><td>340</td><td>120</td><td>2PSR340120-AL</td><td></td><td>5.700,00</td></tr> <tr><td>360</td><td>120</td><td>2PSR360120-AL</td><td></td><td>5.940,00</td></tr> </tbody> </table>	L cm	P cm	COD.	 AL	€ - Eur	160	90	2PSR16090-AL		2.970,00	180	90	2PSR18090-AL		3.180,00	200	90	2PSR20090-AL		3.490,00	220	90	2PSR22090-AL		3.920,00	240	90	2PSR24090-AL		4.010,00	200	100	2PSR200100-AL		3.580,00	220	100	2PSR220100-AL		4.010,00	240	100	2PSR240100-AL		4.180,00	260	100	2PSR260100-AL		4.520,00	280	100	2PSR280100-AL		4.810,00	300	100	2PSR300100-AL		4.990,00	240	120	2PSR240120-AL		4.320,00	260	120	2PSR260120-AL		4.840,00	280	120	2PSR280120-AL		5.120,00	300	120	2PSR300120-AL		5.240,00	320	120	2PSR320120-AL		5.470,00	340	120	2PSR340120-AL		5.700,00	360	120	2PSR360120-AL		5.940,00
L cm	P cm	COD.	 BO	COD.	 NM	€ - Eur																																																																																																																																																																																																																																
160	90	2PSR16090-BO		2PSR16090-NM		2.660,00																																																																																																																																																																																																																																
180	90	2PSR18090-BO		2PSR18090-NM		2.870,00																																																																																																																																																																																																																																
200	90	2PSR20090-BO		2PSR20090-NM		3.180,00																																																																																																																																																																																																																																
220	90	2PSR22090-BO		2PSR22090-NM		3.480,00																																																																																																																																																																																																																																
240	90	2PSR24090-BO		2PSR24090-NM		3.570,00																																																																																																																																																																																																																																
200	100	2PSR200100-BO		2PSR200100-NM		3.270,00																																																																																																																																																																																																																																
220	100	2PSR220100-BO		2PSR220100-NM		3.570,00																																																																																																																																																																																																																																
240	100	2PSR240100-BO		2PSR240100-NM		3.740,00																																																																																																																																																																																																																																
260	100	2PSR260100-BO		2PSR260100-NM		4.080,00																																																																																																																																																																																																																																
280	100	2PSR280100-BO		2PSR280100-NM		4.370,00																																																																																																																																																																																																																																
300	100	2PSR300100-BO		2PSR300100-NM		4.550,00																																																																																																																																																																																																																																
240	120	2PSR240120-BO		2PSR240120-NM		3.860,00																																																																																																																																																																																																																																
260	120	2PSR260120-BO		2PSR260120-NM		4.400,00																																																																																																																																																																																																																																
280	120	2PSR280120-BO		2PSR280120-NM		4.680,00																																																																																																																																																																																																																																
300	120	2PSR300120-BO		2PSR300120-NM		4.800,00																																																																																																																																																																																																																																
320	120	2PSR320120-BO		2PSR320120-NM		5.030,00																																																																																																																																																																																																																																
340	120	2PSR340120-BO		2PSR340120-NM		5.260,00																																																																																																																																																																																																																																
360	120	2PSR360120-BO		2PSR360120-NM		5.500,00																																																																																																																																																																																																																																
L cm	P cm	COD.	 AL	€ - Eur																																																																																																																																																																																																																																		
160	90	2PSR16090-AL		2.970,00																																																																																																																																																																																																																																		
180	90	2PSR18090-AL		3.180,00																																																																																																																																																																																																																																		
200	90	2PSR20090-AL		3.490,00																																																																																																																																																																																																																																		
220	90	2PSR22090-AL		3.920,00																																																																																																																																																																																																																																		
240	90	2PSR24090-AL		4.010,00																																																																																																																																																																																																																																		
200	100	2PSR200100-AL		3.580,00																																																																																																																																																																																																																																		
220	100	2PSR220100-AL		4.010,00																																																																																																																																																																																																																																		
240	100	2PSR240100-AL		4.180,00																																																																																																																																																																																																																																		
260	100	2PSR260100-AL		4.520,00																																																																																																																																																																																																																																		
280	100	2PSR280100-AL		4.810,00																																																																																																																																																																																																																																		
300	100	2PSR300100-AL		4.990,00																																																																																																																																																																																																																																		
240	120	2PSR240120-AL		4.320,00																																																																																																																																																																																																																																		
260	120	2PSR260120-AL		4.840,00																																																																																																																																																																																																																																		
280	120	2PSR280120-AL		5.120,00																																																																																																																																																																																																																																		
300	120	2PSR300120-AL		5.240,00																																																																																																																																																																																																																																		
320	120	2PSR320120-AL		5.470,00																																																																																																																																																																																																																																		
340	120	2PSR340120-AL		5.700,00																																																																																																																																																																																																																																		
360	120	2PSR360120-AL		5.940,00																																																																																																																																																																																																																																		

Colore struttura
Frame color



NM
Nero micaceo.
Micaceous black.
Noir micacé.
Negro micáceo.
Schwarz glimmerhaltig.



BO
Bianco opaco.
Mat white.
Blanc opaque.
Blanco mate.
Mattweiss.

















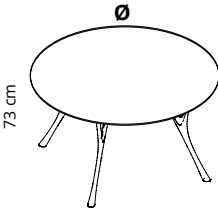









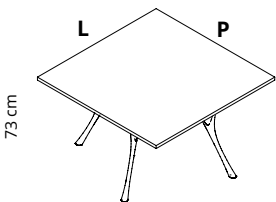







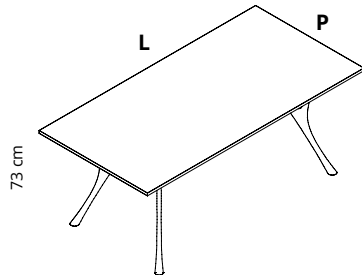

AL
Alluminio lucidato.
Polished aluminium.
Aluminium poli.
Aluminio brillante.
Poliertes Aluminium.

Piano: Resina acrilica bianca
Tabletop: White brushed acrylic
Plateau: Résine acrylique blanche
Tablero: Resina acrílica blanca
Tischplatte: Weißem gebürstetem Acrylharz



Dettaglio piano
Detail tabletop



Piano Tabletop  CEMENTO Colore struttura Frame color  BO  NM  AL	Tavoli piano CEMENTO e struttura bianco opaco (BO) o nero micaceo (NM) Tables with CEMENT tabletop and mat white (BO) or micaceous black frame (NM)	Tavoli piano CEMENTO e struttura alluminio lucidato (AL) Tables with CEMENT tabletop and polished aluminium frame (AL)																																																																																																																																																																																																																																				
	<table border="1"> <thead> <tr> <th>Ø cm</th> <th>COD.</th> <th></th> <th>COD.</th> <th></th> <th>€ - Eur</th> </tr> </thead> <tbody> <tr> <td>130</td> <td>2PCT130-BO</td> <td></td> <td>2PCT130-NM</td> <td></td> <td>2.870,00</td> </tr> <tr> <td>150</td> <td>2PCT150-BO</td> <td></td> <td>2PCT150-NM</td> <td></td> <td>3.190,00</td> </tr> </tbody> </table>	Ø cm	COD.		COD.		€ - Eur	130	2PCT130-BO		2PCT130-NM		2.870,00	150	2PCT150-BO		2PCT150-NM		3.190,00	<table border="1"> <thead> <tr> <th>Ø cm</th> <th>COD.</th> <th></th> <th>€ - Eur</th> </tr> </thead> <tbody> <tr> <td>130</td> <td>2PCT130-AL</td> <td></td> <td>3.170,00</td> </tr> <tr> <td>150</td> <td>2PCT150-AL</td> <td></td> <td>3.490,00</td> </tr> </tbody> </table>	Ø cm	COD.		€ - Eur	130	2PCT130-AL		3.170,00	150	2PCT150-AL		3.490,00																																																																																																																																																																																																						
Ø cm	COD.		COD.		€ - Eur																																																																																																																																																																																																																																	
130	2PCT130-BO		2PCT130-NM		2.870,00																																																																																																																																																																																																																																	
150	2PCT150-BO		2PCT150-NM		3.190,00																																																																																																																																																																																																																																	
Ø cm	COD.		€ - Eur																																																																																																																																																																																																																																			
130	2PCT130-AL		3.170,00																																																																																																																																																																																																																																			
150	2PCT150-AL		3.490,00																																																																																																																																																																																																																																			
	<table border="1"> <thead> <tr> <th>L cm</th> <th>P cm</th> <th>COD.</th> <th></th> <th>COD.</th> <th></th> <th>€ - Eur</th> </tr> </thead> <tbody> <tr> <td>140</td> <td>140</td> <td>2PCQ140140-BO</td> <td></td> <td>2PCQ140140-NM</td> <td></td> <td>3.130,00</td> </tr> </tbody> </table>	L cm	P cm	COD.		COD.		€ - Eur	140	140	2PCQ140140-BO		2PCQ140140-NM		3.130,00	<table border="1"> <thead> <tr> <th>L cm</th> <th>P cm</th> <th>COD.</th> <th></th> <th>€ - Eur</th> </tr> </thead> <tbody> <tr> <td>140</td> <td>140</td> <td>2PCQ140140-AL</td> <td></td> <td>3.430,00</td> </tr> </tbody> </table>	L cm	P cm	COD.		€ - Eur	140	140	2PCQ140140-AL		3.430,00																																																																																																																																																																																																												
L cm	P cm	COD.		COD.		€ - Eur																																																																																																																																																																																																																																
140	140	2PCQ140140-BO		2PCQ140140-NM		3.130,00																																																																																																																																																																																																																																
L cm	P cm	COD.		€ - Eur																																																																																																																																																																																																																																		
140	140	2PCQ140140-AL		3.430,00																																																																																																																																																																																																																																		
	<table border="1"> <thead> <tr> <th>L cm</th> <th>P cm</th> <th>COD.</th> <th></th> <th>COD.</th> <th></th> <th>€ - Eur</th> </tr> </thead> <tbody> <tr><td>160</td><td>90</td><td>2PCR16090-BO</td><td></td><td>2PCR16090-NM</td><td></td><td>2.660,00</td></tr> <tr><td>180</td><td>90</td><td>2PCR18090-BO</td><td></td><td>2PCR18090-NM</td><td></td><td>2.870,00</td></tr> <tr><td>200</td><td>90</td><td>2PCR20090-BO</td><td></td><td>2PCR20090-NM</td><td></td><td>3.180,00</td></tr> <tr><td>220</td><td>90</td><td>2PCR22090-BO</td><td></td><td>2PCR22090-NM</td><td></td><td>3.480,00</td></tr> <tr><td>240</td><td>90</td><td>2PCR24090-BO</td><td></td><td>2PCR24090-NM</td><td></td><td>3.570,00</td></tr> <tr><td>200</td><td>100</td><td>2PCR200100-BO</td><td></td><td>2PCR200100-NM</td><td></td><td>3.270,00</td></tr> <tr><td>220</td><td>100</td><td>2PCR220100-BO</td><td></td><td>2PCR220100-NM</td><td></td><td>3.570,00</td></tr> <tr><td>240</td><td>100</td><td>2PCR240100-BO</td><td></td><td>2PCR240100-NM</td><td></td><td>3.740,00</td></tr> <tr><td>260</td><td>100</td><td>2PCR260100-BO</td><td></td><td>2PCR260100-NM</td><td></td><td>4.080,00</td></tr> <tr><td>280</td><td>100</td><td>2PCR280100-BO</td><td></td><td>2PCR280100-NM</td><td></td><td>4.370,00</td></tr> <tr><td>300</td><td>100</td><td>2PCR300100-BO</td><td></td><td>2PCR300100-NM</td><td></td><td>4.550,00</td></tr> <tr><td>240</td><td>120</td><td>2PCR240120-BO</td><td></td><td>2PCR240120-NM</td><td></td><td>3.860,00</td></tr> <tr><td>260</td><td>120</td><td>2PCR260120-BO</td><td></td><td>2PCR260120-NM</td><td></td><td>4.400,00</td></tr> <tr><td>280</td><td>120</td><td>2PCR280120-BO</td><td></td><td>2PCR280120-NM</td><td></td><td>4.680,00</td></tr> <tr><td>300</td><td>120</td><td>2PCR300120-BO</td><td></td><td>2PCR300120-NM</td><td></td><td>4.800,00</td></tr> <tr><td>320</td><td>120</td><td>2PCR320120-BO</td><td></td><td>2PCR320120-NM</td><td></td><td>5.030,00</td></tr> <tr><td>340</td><td>120</td><td>2PCR340120-BO</td><td></td><td>2PCR340120-NM</td><td></td><td>5.260,00</td></tr> <tr><td>360</td><td>120</td><td>2PCR360120-BO</td><td></td><td>2PCR360120-NM</td><td></td><td>5.500,00</td></tr> </tbody> </table>	L cm	P cm	COD.		COD.		€ - Eur	160	90	2PCR16090-BO		2PCR16090-NM		2.660,00	180	90	2PCR18090-BO		2PCR18090-NM		2.870,00	200	90	2PCR20090-BO		2PCR20090-NM		3.180,00	220	90	2PCR22090-BO		2PCR22090-NM		3.480,00	240	90	2PCR24090-BO		2PCR24090-NM		3.570,00	200	100	2PCR200100-BO		2PCR200100-NM		3.270,00	220	100	2PCR220100-BO		2PCR220100-NM		3.570,00	240	100	2PCR240100-BO		2PCR240100-NM		3.740,00	260	100	2PCR260100-BO		2PCR260100-NM		4.080,00	280	100	2PCR280100-BO		2PCR280100-NM		4.370,00	300	100	2PCR300100-BO		2PCR300100-NM		4.550,00	240	120	2PCR240120-BO		2PCR240120-NM		3.860,00	260	120	2PCR260120-BO		2PCR260120-NM		4.400,00	280	120	2PCR280120-BO		2PCR280120-NM		4.680,00	300	120	2PCR300120-BO		2PCR300120-NM		4.800,00	320	120	2PCR320120-BO		2PCR320120-NM		5.030,00	340	120	2PCR340120-BO		2PCR340120-NM		5.260,00	360	120	2PCR360120-BO		2PCR360120-NM		5.500,00	<table border="1"> <thead> <tr> <th>L cm</th> <th>P cm</th> <th>COD.</th> <th></th> <th>€ - Eur</th> </tr> </thead> <tbody> <tr><td>160</td><td>90</td><td>2PCR16090-AL</td><td></td><td>2.970,00</td></tr> <tr><td>180</td><td>90</td><td>2PCR18090-AL</td><td></td><td>3.180,00</td></tr> <tr><td>200</td><td>90</td><td>2PCR20090-AL</td><td></td><td>3.490,00</td></tr> <tr><td>220</td><td>90</td><td>2PCR22090-AL</td><td></td><td>3.920,00</td></tr> <tr><td>240</td><td>90</td><td>2PCR24090-AL</td><td></td><td>4.010,00</td></tr> <tr><td>200</td><td>100</td><td>2PCR200100-AL</td><td></td><td>3.580,00</td></tr> <tr><td>220</td><td>100</td><td>2PCR220100-AL</td><td></td><td>4.010,00</td></tr> <tr><td>240</td><td>100</td><td>2PCR240100-AL</td><td></td><td>4.180,00</td></tr> <tr><td>260</td><td>100</td><td>2PCR260100-AL</td><td></td><td>4.520,00</td></tr> <tr><td>280</td><td>100</td><td>2PCR280100-AL</td><td></td><td>4.810,00</td></tr> <tr><td>300</td><td>100</td><td>2PCR300100-AL</td><td></td><td>4.990,00</td></tr> <tr><td>240</td><td>120</td><td>2PCR240120-AL</td><td></td><td>4.320,00</td></tr> <tr><td>260</td><td>120</td><td>2PCR260120-AL</td><td></td><td>4.480,00</td></tr> <tr><td>280</td><td>120</td><td>2PCR280120-AL</td><td></td><td>5.120,00</td></tr> <tr><td>300</td><td>120</td><td>2PCR300120-AL</td><td></td><td>5.240,00</td></tr> <tr><td>320</td><td>120</td><td>2PCR320120-AL</td><td></td><td>5.470,00</td></tr> <tr><td>340</td><td>120</td><td>2PCR340120-AL</td><td></td><td>5.700,00</td></tr> <tr><td>360</td><td>120</td><td>2PCR360120-AL</td><td></td><td>5.940,00</td></tr> </tbody> </table>	L cm	P cm	COD.		€ - Eur	160	90	2PCR16090-AL		2.970,00	180	90	2PCR18090-AL		3.180,00	200	90	2PCR20090-AL		3.490,00	220	90	2PCR22090-AL		3.920,00	240	90	2PCR24090-AL		4.010,00	200	100	2PCR200100-AL		3.580,00	220	100	2PCR220100-AL		4.010,00	240	100	2PCR240100-AL		4.180,00	260	100	2PCR260100-AL		4.520,00	280	100	2PCR280100-AL		4.810,00	300	100	2PCR300100-AL		4.990,00	240	120	2PCR240120-AL		4.320,00	260	120	2PCR260120-AL		4.480,00	280	120	2PCR280120-AL		5.120,00	300	120	2PCR300120-AL		5.240,00	320	120	2PCR320120-AL		5.470,00	340	120	2PCR340120-AL		5.700,00	360	120	2PCR360120-AL		5.940,00
L cm	P cm	COD.		COD.		€ - Eur																																																																																																																																																																																																																																
160	90	2PCR16090-BO		2PCR16090-NM		2.660,00																																																																																																																																																																																																																																
180	90	2PCR18090-BO		2PCR18090-NM		2.870,00																																																																																																																																																																																																																																
200	90	2PCR20090-BO		2PCR20090-NM		3.180,00																																																																																																																																																																																																																																
220	90	2PCR22090-BO		2PCR22090-NM		3.480,00																																																																																																																																																																																																																																
240	90	2PCR24090-BO		2PCR24090-NM		3.570,00																																																																																																																																																																																																																																
200	100	2PCR200100-BO		2PCR200100-NM		3.270,00																																																																																																																																																																																																																																
220	100	2PCR220100-BO		2PCR220100-NM		3.570,00																																																																																																																																																																																																																																
240	100	2PCR240100-BO		2PCR240100-NM		3.740,00																																																																																																																																																																																																																																
260	100	2PCR260100-BO		2PCR260100-NM		4.080,00																																																																																																																																																																																																																																
280	100	2PCR280100-BO		2PCR280100-NM		4.370,00																																																																																																																																																																																																																																
300	100	2PCR300100-BO		2PCR300100-NM		4.550,00																																																																																																																																																																																																																																
240	120	2PCR240120-BO		2PCR240120-NM		3.860,00																																																																																																																																																																																																																																
260	120	2PCR260120-BO		2PCR260120-NM		4.400,00																																																																																																																																																																																																																																
280	120	2PCR280120-BO		2PCR280120-NM		4.680,00																																																																																																																																																																																																																																
300	120	2PCR300120-BO		2PCR300120-NM		4.800,00																																																																																																																																																																																																																																
320	120	2PCR320120-BO		2PCR320120-NM		5.030,00																																																																																																																																																																																																																																
340	120	2PCR340120-BO		2PCR340120-NM		5.260,00																																																																																																																																																																																																																																
360	120	2PCR360120-BO		2PCR360120-NM		5.500,00																																																																																																																																																																																																																																
L cm	P cm	COD.		€ - Eur																																																																																																																																																																																																																																		
160	90	2PCR16090-AL		2.970,00																																																																																																																																																																																																																																		
180	90	2PCR18090-AL		3.180,00																																																																																																																																																																																																																																		
200	90	2PCR20090-AL		3.490,00																																																																																																																																																																																																																																		
220	90	2PCR22090-AL		3.920,00																																																																																																																																																																																																																																		
240	90	2PCR24090-AL		4.010,00																																																																																																																																																																																																																																		
200	100	2PCR200100-AL		3.580,00																																																																																																																																																																																																																																		
220	100	2PCR220100-AL		4.010,00																																																																																																																																																																																																																																		
240	100	2PCR240100-AL		4.180,00																																																																																																																																																																																																																																		
260	100	2PCR260100-AL		4.520,00																																																																																																																																																																																																																																		
280	100	2PCR280100-AL		4.810,00																																																																																																																																																																																																																																		
300	100	2PCR300100-AL		4.990,00																																																																																																																																																																																																																																		
240	120	2PCR240120-AL		4.320,00																																																																																																																																																																																																																																		
260	120	2PCR260120-AL		4.480,00																																																																																																																																																																																																																																		
280	120	2PCR280120-AL		5.120,00																																																																																																																																																																																																																																		
300	120	2PCR300120-AL		5.240,00																																																																																																																																																																																																																																		
320	120	2PCR320120-AL		5.470,00																																																																																																																																																																																																																																		
340	120	2PCR340120-AL		5.700,00																																																																																																																																																																																																																																		
360	120	2PCR360120-AL		5.940,00																																																																																																																																																																																																																																		

Colore struttura
Frame color



NM
Nero micaceo.
Micaceous black.
Noir micacé.
Negro micáceo.
Schwarz glimmerhaltig.



BO
Bianco opaco.
Mat white.
Blanc opaque.
Blanco mate.
Mattweiss.

















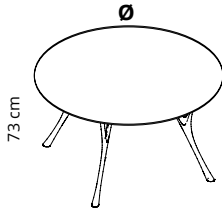









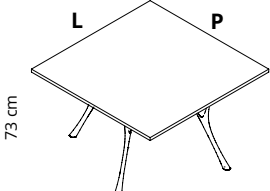









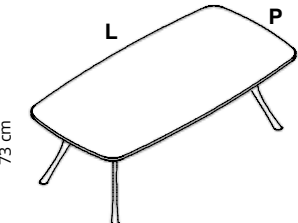







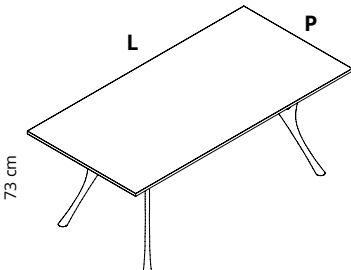

AL
Alluminio lucidato.
Polished aluminium.
Aluminium poli.
Aluminio brillante.
Poliertes Aluminium.

Piano: cemento
Tabletop: cement
Plateau: béton
Tablero: Hormigón
Tischplatte: Zement



Dettaglio piano
Detail tabletop



Piano Tabletop  BRONZO Colore struttura Frame color  BO  NM  AL	Tavoli piano BRONZO e struttura bianco opaco (BO) o nero micaceo (NM) Tables with BRONZE tabletop and mat white (BO) or micaceous black frame (NM)	Tavoli piano BRONZO e struttura alluminio lucidato (AL) Tables with BRONZE tabletop and polished aluminium frame (AL)																																																
	<table border="1"> <thead> <tr> <th>Ø cm</th> <th>COD.</th> <th></th> <th>COD.</th> <th></th> <th>€ - Eur</th> </tr> </thead> <tbody> <tr> <td>130</td> <td>2PGT130-BO</td> <td></td> <td>2PGT130-NM</td> <td></td> <td>3.180,00</td> </tr> <tr> <td>150</td> <td>2PGT150-BO</td> <td></td> <td>2PGT150-NM</td> <td></td> <td>3.820,00</td> </tr> </tbody> </table>	Ø cm	COD.		COD.		€ - Eur	130	2PGT130-BO		2PGT130-NM		3.180,00	150	2PGT150-BO		2PGT150-NM		3.820,00	<table border="1"> <thead> <tr> <th>Ø cm</th> <th>COD.</th> <th></th> <th>€ - Eur</th> </tr> </thead> <tbody> <tr> <td>130</td> <td>2PGT130-AL</td> <td></td> <td>3.480,00</td> </tr> <tr> <td>150</td> <td>2PGT150-AL</td> <td></td> <td>4.120,00</td> </tr> </tbody> </table>	Ø cm	COD.		€ - Eur	130	2PGT130-AL		3.480,00	150	2PGT150-AL		4.120,00																		
Ø cm	COD.		COD.		€ - Eur																																													
130	2PGT130-BO		2PGT130-NM		3.180,00																																													
150	2PGT150-BO		2PGT150-NM		3.820,00																																													
Ø cm	COD.		€ - Eur																																															
130	2PGT130-AL		3.480,00																																															
150	2PGT150-AL		4.120,00																																															
	<table border="1"> <thead> <tr> <th>L cm</th> <th>P cm</th> <th>COD.</th> <th></th> <th>COD.</th> <th></th> <th>€ - Eur</th> </tr> </thead> <tbody> <tr> <td>140</td> <td>140</td> <td>2PGQ140140-BO</td> <td></td> <td>2PGQ140140-NM</td> <td></td> <td>3.510,00</td> </tr> </tbody> </table>	L cm	P cm	COD.		COD.		€ - Eur	140	140	2PGQ140140-BO		2PGQ140140-NM		3.510,00	<table border="1"> <thead> <tr> <th>L cm</th> <th>P cm</th> <th>COD.</th> <th></th> <th>€ - Eur</th> </tr> </thead> <tbody> <tr> <td>140</td> <td>140</td> <td>2PGQ140140-AL</td> <td></td> <td>3.810,00</td> </tr> </tbody> </table>	L cm	P cm	COD.		€ - Eur	140	140	2PGQ140140-AL		3.810,00																								
L cm	P cm	COD.		COD.		€ - Eur																																												
140	140	2PGQ140140-BO		2PGQ140140-NM		3.510,00																																												
L cm	P cm	COD.		€ - Eur																																														
140	140	2PGQ140140-AL		3.810,00																																														
	<table border="1"> <thead> <tr> <th>L cm</th> <th>P cm</th> <th>COD.</th> <th></th> <th>COD.</th> <th></th> <th>€ - Eur</th> </tr> </thead> <tbody> <tr> <td>200</td> <td>100</td> <td>2PGS200100-BO</td> <td></td> <td>2PGS200100-NM</td> <td></td> <td>3.640,00</td> </tr> <tr> <td>240</td> <td>110</td> <td>2PGS240110-BO</td> <td></td> <td>2PGS240110-NM</td> <td></td> <td>4.400,00</td> </tr> <tr> <td>300</td> <td>120</td> <td>2PGS300120-BO</td> <td></td> <td>2PGS300120-NM</td> <td></td> <td>5.760,00</td> </tr> </tbody> </table>	L cm	P cm	COD.		COD.		€ - Eur	200	100	2PGS200100-BO		2PGS200100-NM		3.640,00	240	110	2PGS240110-BO		2PGS240110-NM		4.400,00	300	120	2PGS300120-BO		2PGS300120-NM		5.760,00	<table border="1"> <thead> <tr> <th>L cm</th> <th>P cm</th> <th>COD.</th> <th></th> <th>€ - Eur</th> </tr> </thead> <tbody> <tr> <td>200</td> <td>100</td> <td>2PGS200100-AL</td> <td></td> <td>3.950,00</td> </tr> <tr> <td>240</td> <td>110</td> <td>2PGS240110-AL</td> <td></td> <td>4.840,00</td> </tr> <tr> <td>300</td> <td>120</td> <td>2PGS300120-AL</td> <td></td> <td>6.200,00</td> </tr> </tbody> </table>	L cm	P cm	COD.		€ - Eur	200	100	2PGS200100-AL		3.950,00	240	110	2PGS240110-AL		4.840,00	300	120	2PGS300120-AL		6.200,00
L cm	P cm	COD.		COD.		€ - Eur																																												
200	100	2PGS200100-BO		2PGS200100-NM		3.640,00																																												
240	110	2PGS240110-BO		2PGS240110-NM		4.400,00																																												
300	120	2PGS300120-BO		2PGS300120-NM		5.760,00																																												
L cm	P cm	COD.		€ - Eur																																														
200	100	2PGS200100-AL		3.950,00																																														
240	110	2PGS240110-AL		4.840,00																																														
300	120	2PGS300120-AL		6.200,00																																														
	<table border="1"> <thead> <tr> <th>L cm</th> <th>P cm</th> <th>COD.</th> <th></th> <th>COD.</th> <th></th> <th>€ - Eur</th> </tr> </thead> <tbody> <tr> <td>200</td> <td>90</td> <td>2PGR20090-BO</td> <td></td> <td>2PGR20090-NM</td> <td></td> <td>3.380,00</td> </tr> <tr> <td>240</td> <td>100</td> <td>2PGR240100-BO</td> <td></td> <td>2PGR240100-NM</td> <td></td> <td>4.180,00</td> </tr> <tr> <td>300</td> <td>120</td> <td>2PGR300120-BO</td> <td></td> <td>2PGR300120-NM</td> <td></td> <td>5.540,00</td> </tr> </tbody> </table>	L cm	P cm	COD.		COD.		€ - Eur	200	90	2PGR20090-BO		2PGR20090-NM		3.380,00	240	100	2PGR240100-BO		2PGR240100-NM		4.180,00	300	120	2PGR300120-BO		2PGR300120-NM		5.540,00	<table border="1"> <thead> <tr> <th>L cm</th> <th>P cm</th> <th>COD.</th> <th></th> <th>€ - Eur</th> </tr> </thead> <tbody> <tr> <td>200</td> <td>90</td> <td>2PGR20090-AL</td> <td></td> <td>3.690,00</td> </tr> <tr> <td>240</td> <td>100</td> <td>2PGR240100-AL</td> <td></td> <td>4.620,00</td> </tr> <tr> <td>300</td> <td>120</td> <td>2PGR300120-AL</td> <td></td> <td>5.980,00</td> </tr> </tbody> </table>	L cm	P cm	COD.		€ - Eur	200	90	2PGR20090-AL		3.690,00	240	100	2PGR240100-AL		4.620,00	300	120	2PGR300120-AL		5.980,00
L cm	P cm	COD.		COD.		€ - Eur																																												
200	90	2PGR20090-BO		2PGR20090-NM		3.380,00																																												
240	100	2PGR240100-BO		2PGR240100-NM		4.180,00																																												
300	120	2PGR300120-BO		2PGR300120-NM		5.540,00																																												
L cm	P cm	COD.		€ - Eur																																														
200	90	2PGR20090-AL		3.690,00																																														
240	100	2PGR240100-AL		4.620,00																																														
300	120	2PGR300120-AL		5.980,00																																														

Colore struttura
Frame color



NM
Nero micaceo.
Micaceous black.
Noir micacé.
Negro micáceo.
Schwarz glimmerhaltig.



BO
Bianco opaco.
Mat white.
Blanc opaque.
Blanco mate.
Mattweiss.

















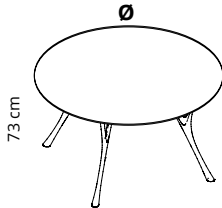









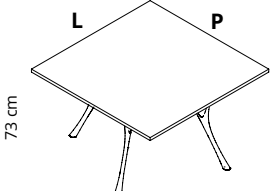









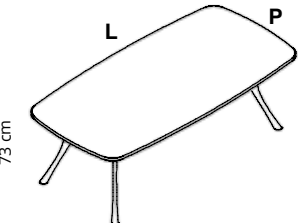







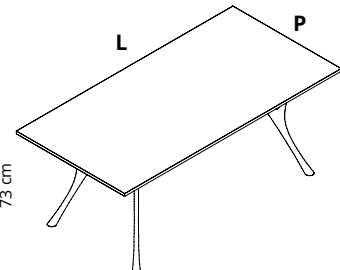

AL
Alluminio lucidato.
Polished aluminium.
Aluminium poli.
Aluminio brillante.
Poliertes Aluminium.

Piano: Finitura bronzo fuso
Tabletop: Molten bronze finish
Plateau: Finition bronze fondu
Tablero: Finición bronce fundido
Tischplatte: Bronzeguss-Optik



Dettaglio piano
Detail tabletop



Piano Tabletop  ROVERE CHIARO	Colore struttura Frame color  BO  NM  AL	Tavoli piano ROVERE CHIARO e struttura bianco opaco (BO) o nero micaceo (NM) Tables with LIGHT OAK tabletop and mat white (BO) or micaceous black frame (NM)	Tavoli piano ROVERE CHIARO e struttura alluminio lucidato (AL) Tables with LIGHT OAK tabletop and polished aluminium frame (AL)																																															
	<table border="0"> <thead> <tr> <th>Ø cm</th> <th>COD.</th> <th></th> <th>COD.</th> <th></th> <th>€ - Eur</th> </tr> </thead> <tbody> <tr> <td>130</td> <td>2PRCT130-BO</td> <td></td> <td>2PRCT130-NM</td> <td></td> <td>4.150,00</td> </tr> <tr> <td>150</td> <td>2PRCT150-BO</td> <td></td> <td>2PRCT150-NM</td> <td></td> <td>4.990,00</td> </tr> </tbody> </table>	Ø cm	COD.		COD.		€ - Eur	130	2PRCT130-BO		2PRCT130-NM		4.150,00	150	2PRCT150-BO		2PRCT150-NM		4.990,00	<table border="0"> <thead> <tr> <th>Ø cm</th> <th>COD.</th> <th></th> <th>€ - Eur</th> </tr> </thead> <tbody> <tr> <td>130</td> <td>2PRCT130-AL</td> <td></td> <td>4.380,00</td> </tr> <tr> <td>150</td> <td>2PRCT150-AL</td> <td></td> <td>5.290,00</td> </tr> </tbody> </table>	Ø cm	COD.		€ - Eur	130	2PRCT130-AL		4.380,00	150	2PRCT150-AL		5.290,00																		
Ø cm	COD.		COD.		€ - Eur																																													
130	2PRCT130-BO		2PRCT130-NM		4.150,00																																													
150	2PRCT150-BO		2PRCT150-NM		4.990,00																																													
Ø cm	COD.		€ - Eur																																															
130	2PRCT130-AL		4.380,00																																															
150	2PRCT150-AL		5.290,00																																															
	<table border="0"> <thead> <tr> <th>L cm</th> <th>P cm</th> <th>COD.</th> <th></th> <th>COD.</th> <th></th> <th>€ - Eur</th> </tr> </thead> <tbody> <tr> <td>140</td> <td>140</td> <td>2PRCQ140140-BO</td> <td></td> <td>2PRCQ140140-NM</td> <td></td> <td>4.770,00</td> </tr> </tbody> </table>	L cm	P cm	COD.		COD.		€ - Eur	140	140	2PRCQ140140-BO		2PRCQ140140-NM		4.770,00	<table border="0"> <thead> <tr> <th>L cm</th> <th>P cm</th> <th>COD.</th> <th></th> <th>€ - Eur</th> </tr> </thead> <tbody> <tr> <td>140</td> <td>140</td> <td>2PRCQ140140-AL</td> <td></td> <td>5.070,00</td> </tr> </tbody> </table>	L cm	P cm	COD.		€ - Eur	140	140	2PRCQ140140-AL		5.070,00																								
L cm	P cm	COD.		COD.		€ - Eur																																												
140	140	2PRCQ140140-BO		2PRCQ140140-NM		4.770,00																																												
L cm	P cm	COD.		€ - Eur																																														
140	140	2PRCQ140140-AL		5.070,00																																														
	<table border="0"> <thead> <tr> <th>L cm</th> <th>P cm</th> <th>COD.</th> <th></th> <th>COD.</th> <th></th> <th>€ - Eur</th> </tr> </thead> <tbody> <tr> <td>200</td> <td>100</td> <td>2PRCS200100-BO</td> <td></td> <td>2PRCS200100-NM</td> <td></td> <td>4.670,00</td> </tr> <tr> <td>240</td> <td>110</td> <td>2PRCS240110-BO</td> <td></td> <td>2PRCS240110-NM</td> <td></td> <td>5.555,00</td> </tr> <tr> <td>300</td> <td>120</td> <td>2PRCS300120-BO</td> <td></td> <td>2PRCS300120-NM</td> <td></td> <td>7.344,00</td> </tr> </tbody> </table>	L cm	P cm	COD.		COD.		€ - Eur	200	100	2PRCS200100-BO		2PRCS200100-NM		4.670,00	240	110	2PRCS240110-BO		2PRCS240110-NM		5.555,00	300	120	2PRCS300120-BO		2PRCS300120-NM		7.344,00	<table border="0"> <thead> <tr> <th>L cm</th> <th>P cm</th> <th>COD.</th> <th></th> <th>€ - Eur</th> </tr> </thead> <tbody> <tr> <td>200</td> <td>100</td> <td>2PRCS200100-AL</td> <td></td> <td>4.976,00</td> </tr> <tr> <td>240</td> <td>110</td> <td>2PRCS240110-AL</td> <td></td> <td>5.995,00</td> </tr> <tr> <td>300</td> <td>120</td> <td>2PRCS300120-AL</td> <td></td> <td>7.784,00</td> </tr> </tbody> </table>	L cm	P cm	COD.		€ - Eur	200	100	2PRCS200100-AL		4.976,00	240	110	2PRCS240110-AL		5.995,00	300	120	2PRCS300120-AL		7.784,00
L cm	P cm	COD.		COD.		€ - Eur																																												
200	100	2PRCS200100-BO		2PRCS200100-NM		4.670,00																																												
240	110	2PRCS240110-BO		2PRCS240110-NM		5.555,00																																												
300	120	2PRCS300120-BO		2PRCS300120-NM		7.344,00																																												
L cm	P cm	COD.		€ - Eur																																														
200	100	2PRCS200100-AL		4.976,00																																														
240	110	2PRCS240110-AL		5.995,00																																														
300	120	2PRCS300120-AL		7.784,00																																														
	<table border="0"> <thead> <tr> <th>L cm</th> <th>P cm</th> <th>COD.</th> <th></th> <th>COD.</th> <th></th> <th>€ - Eur</th> </tr> </thead> <tbody> <tr> <td>200</td> <td>90</td> <td>2PRCR20090-BO</td> <td></td> <td>2PRCR20090-NM</td> <td></td> <td>4.370,00</td> </tr> <tr> <td>240</td> <td>100</td> <td>2PRCR240100-BO</td> <td></td> <td>2PRCR240100-NM</td> <td></td> <td>5.370,00</td> </tr> <tr> <td>300</td> <td>120</td> <td>2PRCR300120-BO</td> <td></td> <td>2PRCR300120-NM</td> <td></td> <td>7.220,00</td> </tr> </tbody> </table>	L cm	P cm	COD.		COD.		€ - Eur	200	90	2PRCR20090-BO		2PRCR20090-NM		4.370,00	240	100	2PRCR240100-BO		2PRCR240100-NM		5.370,00	300	120	2PRCR300120-BO		2PRCR300120-NM		7.220,00	<table border="0"> <thead> <tr> <th>L cm</th> <th>P cm</th> <th>COD.</th> <th></th> <th>€ - Eur</th> </tr> </thead> <tbody> <tr> <td>200</td> <td>90</td> <td>2PRCR20090-AL</td> <td></td> <td>4.680,00</td> </tr> <tr> <td>240</td> <td>100</td> <td>2PRCR240100-AL</td> <td></td> <td>5.800,00</td> </tr> <tr> <td>300</td> <td>120</td> <td>2PRCR300120-AL</td> <td></td> <td>7.660,00</td> </tr> </tbody> </table>	L cm	P cm	COD.		€ - Eur	200	90	2PRCR20090-AL		4.680,00	240	100	2PRCR240100-AL		5.800,00	300	120	2PRCR300120-AL		7.660,00
L cm	P cm	COD.		COD.		€ - Eur																																												
200	90	2PRCR20090-BO		2PRCR20090-NM		4.370,00																																												
240	100	2PRCR240100-BO		2PRCR240100-NM		5.370,00																																												
300	120	2PRCR300120-BO		2PRCR300120-NM		7.220,00																																												
L cm	P cm	COD.		€ - Eur																																														
200	90	2PRCR20090-AL		4.680,00																																														
240	100	2PRCR240100-AL		5.800,00																																														
300	120	2PRCR300120-AL		7.660,00																																														

Colore struttura
Frame color



NM
Nero micaceo.
Micaceous black.
Noir micacé.
Negro micáceo.
Schwarz glimmerhaltig.



BO
Bianco opaco.
Mat white.
Blanc opaque.
Blanco mate.
Mattweiss.

















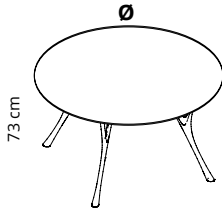









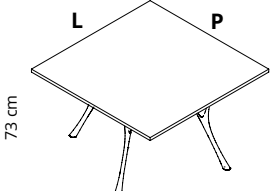









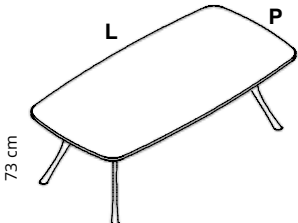







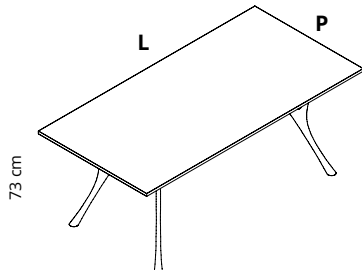

AL
Alluminio lucidato.
Polished aluminium.
Aluminium poli.
Aluminio brillante.
Poliertes Aluminium.

Piano: finitura rovere chiaro
Tabletop: light oak finish
Plateau: finition bois de chêne clair
Tablero: finicion maderá de roble claro
Tischplatte: hellem Eichenholz Optik



Dettaglio piano
Detail tabletop



Piano Tabletop  ROVERE NERO Colore struttura Frame color    BO NM AL	Tavoli piano ROVERE NERO e struttura bianco opaco (BO) o nero micaceo (NM) Tables with BLACK OAK tabletop and mat white (BO) or micaceous black frame (NM)	Tavoli piano ROVERE NERO e struttura alluminio lucidato (AL) Tables with BLACK OAK tabletop and polished aluminium frame (AL)																																																
	<table border="1"> <thead> <tr> <th>Ø cm</th> <th>COD.</th> <th></th> <th>COD.</th> <th></th> <th>€ - Eur</th> </tr> </thead> <tbody> <tr> <td>130</td> <td>2PRNT130-BO</td> <td></td> <td>2PRNT130-NM</td> <td></td> <td>4.150,00</td> </tr> <tr> <td>150</td> <td>2PRNT150-BO</td> <td></td> <td>2PRNT150-NM</td> <td></td> <td>4.990,00</td> </tr> </tbody> </table>	Ø cm	COD.		COD.		€ - Eur	130	2PRNT130-BO		2PRNT130-NM		4.150,00	150	2PRNT150-BO		2PRNT150-NM		4.990,00	<table border="1"> <thead> <tr> <th>Ø cm</th> <th>COD.</th> <th></th> <th>€ - Eur</th> </tr> </thead> <tbody> <tr> <td>130</td> <td>2PRNT130-AL</td> <td></td> <td>4.380,00</td> </tr> <tr> <td>150</td> <td>2PRNT150-AL</td> <td></td> <td>5.290,00</td> </tr> </tbody> </table>	Ø cm	COD.		€ - Eur	130	2PRNT130-AL		4.380,00	150	2PRNT150-AL		5.290,00																		
Ø cm	COD.		COD.		€ - Eur																																													
130	2PRNT130-BO		2PRNT130-NM		4.150,00																																													
150	2PRNT150-BO		2PRNT150-NM		4.990,00																																													
Ø cm	COD.		€ - Eur																																															
130	2PRNT130-AL		4.380,00																																															
150	2PRNT150-AL		5.290,00																																															
	<table border="1"> <thead> <tr> <th>L cm</th> <th>P cm</th> <th>COD.</th> <th></th> <th>COD.</th> <th></th> <th>€ - Eur</th> </tr> </thead> <tbody> <tr> <td>140</td> <td>140</td> <td>2PRNQ140140-BO</td> <td></td> <td>2PRNQ140140-NM</td> <td></td> <td>4.770,00</td> </tr> </tbody> </table>	L cm	P cm	COD.		COD.		€ - Eur	140	140	2PRNQ140140-BO		2PRNQ140140-NM		4.770,00	<table border="1"> <thead> <tr> <th>L cm</th> <th>P cm</th> <th>COD.</th> <th></th> <th>€ - Eur</th> </tr> </thead> <tbody> <tr> <td>140</td> <td>140</td> <td>2PRNQ140140-AL</td> <td></td> <td>5.070,00</td> </tr> </tbody> </table>	L cm	P cm	COD.		€ - Eur	140	140	2PRNQ140140-AL		5.070,00																								
L cm	P cm	COD.		COD.		€ - Eur																																												
140	140	2PRNQ140140-BO		2PRNQ140140-NM		4.770,00																																												
L cm	P cm	COD.		€ - Eur																																														
140	140	2PRNQ140140-AL		5.070,00																																														
	<table border="1"> <thead> <tr> <th>L cm</th> <th>P cm</th> <th>COD.</th> <th></th> <th>COD.</th> <th></th> <th>€ - Eur</th> </tr> </thead> <tbody> <tr> <td>200</td> <td>100</td> <td>2PRNS200100-BO</td> <td></td> <td>2PRNS200100-NM</td> <td></td> <td>4.670,00</td> </tr> <tr> <td>240</td> <td>110</td> <td>2PRNS240110-BO</td> <td></td> <td>2PRNS240110-NM</td> <td></td> <td>5.555,00</td> </tr> <tr> <td>300</td> <td>120</td> <td>2PRNS300120-BO</td> <td></td> <td>2PRNS300120-NM</td> <td></td> <td>7.344,00</td> </tr> </tbody> </table>	L cm	P cm	COD.		COD.		€ - Eur	200	100	2PRNS200100-BO		2PRNS200100-NM		4.670,00	240	110	2PRNS240110-BO		2PRNS240110-NM		5.555,00	300	120	2PRNS300120-BO		2PRNS300120-NM		7.344,00	<table border="1"> <thead> <tr> <th>L cm</th> <th>P cm</th> <th>COD.</th> <th></th> <th>€ - Eur</th> </tr> </thead> <tbody> <tr> <td>200</td> <td>100</td> <td>2PRNS200100-AL</td> <td></td> <td>4.976,00</td> </tr> <tr> <td>240</td> <td>110</td> <td>2PRNS240110-AL</td> <td></td> <td>5.995,00</td> </tr> <tr> <td>300</td> <td>120</td> <td>2PRNS300120-AL</td> <td></td> <td>7.784,00</td> </tr> </tbody> </table>	L cm	P cm	COD.		€ - Eur	200	100	2PRNS200100-AL		4.976,00	240	110	2PRNS240110-AL		5.995,00	300	120	2PRNS300120-AL		7.784,00
L cm	P cm	COD.		COD.		€ - Eur																																												
200	100	2PRNS200100-BO		2PRNS200100-NM		4.670,00																																												
240	110	2PRNS240110-BO		2PRNS240110-NM		5.555,00																																												
300	120	2PRNS300120-BO		2PRNS300120-NM		7.344,00																																												
L cm	P cm	COD.		€ - Eur																																														
200	100	2PRNS200100-AL		4.976,00																																														
240	110	2PRNS240110-AL		5.995,00																																														
300	120	2PRNS300120-AL		7.784,00																																														
	<table border="1"> <thead> <tr> <th>L cm</th> <th>P cm</th> <th>COD.</th> <th></th> <th>COD.</th> <th></th> <th>€ - Eur</th> </tr> </thead> <tbody> <tr> <td>200</td> <td>90</td> <td>2PRNR20090-BO</td> <td></td> <td>2PRNR20090-NM</td> <td></td> <td>4.370,00</td> </tr> <tr> <td>240</td> <td>100</td> <td>2PRNR240100-BO</td> <td></td> <td>2PRNR240100-NM</td> <td></td> <td>5.370,00</td> </tr> <tr> <td>300</td> <td>120</td> <td>2PRNR300120-BO</td> <td></td> <td>2PRNR300120-NM</td> <td></td> <td>7.220,00</td> </tr> </tbody> </table>	L cm	P cm	COD.		COD.		€ - Eur	200	90	2PRNR20090-BO		2PRNR20090-NM		4.370,00	240	100	2PRNR240100-BO		2PRNR240100-NM		5.370,00	300	120	2PRNR300120-BO		2PRNR300120-NM		7.220,00	<table border="1"> <thead> <tr> <th>L cm</th> <th>P cm</th> <th>COD.</th> <th></th> <th>€ - Eur</th> </tr> </thead> <tbody> <tr> <td>200</td> <td>90</td> <td>2PRNR20090-AL</td> <td></td> <td>4.680,00</td> </tr> <tr> <td>240</td> <td>100</td> <td>2PRNR240100-AL</td> <td></td> <td>5.800,00</td> </tr> <tr> <td>300</td> <td>120</td> <td>2PRNR300120-AL</td> <td></td> <td>7.660,00</td> </tr> </tbody> </table>	L cm	P cm	COD.		€ - Eur	200	90	2PRNR20090-AL		4.680,00	240	100	2PRNR240100-AL		5.800,00	300	120	2PRNR300120-AL		7.660,00
L cm	P cm	COD.		COD.		€ - Eur																																												
200	90	2PRNR20090-BO		2PRNR20090-NM		4.370,00																																												
240	100	2PRNR240100-BO		2PRNR240100-NM		5.370,00																																												
300	120	2PRNR300120-BO		2PRNR300120-NM		7.220,00																																												
L cm	P cm	COD.		€ - Eur																																														
200	90	2PRNR20090-AL		4.680,00																																														
240	100	2PRNR240100-AL		5.800,00																																														
300	120	2PRNR300120-AL		7.660,00																																														

Colore struttura
Frame color



NM
Nero micaceo.
Micaceous black.
Noir micacé.
Negro micáceo.
Schwarz glimmerhaltig.



BO
Bianco opaco.
Mat white.
Blanc opaque.
Blanco mate.
Mattweiss.



AL
Alluminio lucidato.
Polished aluminium.
Aluminium poli.
Aluminio brillante.
Poliertes Aluminium.

Piano: finitura rovere nero
Tabletop: black oak finish
Plateau: finition bois de chêne noir
Tablero: finición madera de roble negro
Tischplatte: schwarzem Eichenholz Optik



Dettaglio piano
Detail tabletop

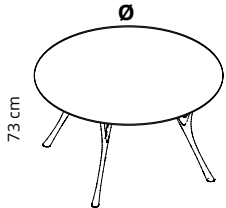
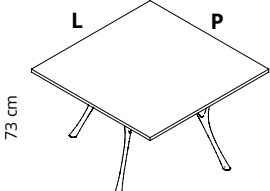
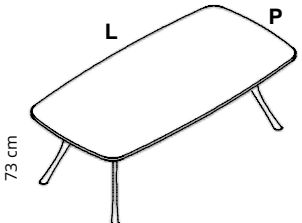
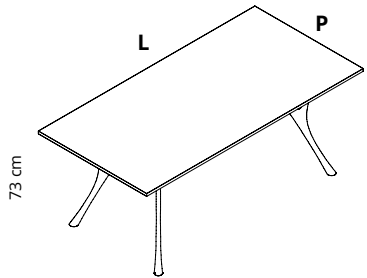

Piano Tabletop  NOCE CANALETTO	Tavoli piano NOCE CANALETTO e struttura bianco opaco (BO) o nero micaceo (NM) Tables with CANALETTO WALNUT tabletop and mat white (BO) or micaceous black frame (NM)	Tavoli piano NOCE CANALETTO e struttura alluminio lucidato (AL) Tables with CANALETTO WALNUT tabletop and polished aluminium frame (AL)																																																
	<table border="1"> <thead> <tr> <th>Ø cm</th> <th>COD.</th> <th>BO</th> <th>COD.</th> <th>NM</th> <th>€ - Eur</th> </tr> </thead> <tbody> <tr> <td>130</td> <td>2PNCT130-BO</td> <td></td> <td>2PNCT130-NM</td> <td></td> <td>4.440,00</td> </tr> <tr> <td>150</td> <td>2PNCT150-BO</td> <td></td> <td>2PNCT150-NM</td> <td></td> <td>5.070,00</td> </tr> </tbody> </table>	Ø cm	COD.	BO	COD.	NM	€ - Eur	130	2PNCT130-BO		2PNCT130-NM		4.440,00	150	2PNCT150-BO		2PNCT150-NM		5.070,00	<table border="1"> <thead> <tr> <th>Ø cm</th> <th>COD.</th> <th>AL</th> <th>€ - Eur</th> </tr> </thead> <tbody> <tr> <td>130</td> <td>2PNCT130-AL</td> <td></td> <td>4.740,00</td> </tr> <tr> <td>150</td> <td>2PNCT150-AL</td> <td></td> <td>5.370,00</td> </tr> </tbody> </table>	Ø cm	COD.	AL	€ - Eur	130	2PNCT130-AL		4.740,00	150	2PNCT150-AL		5.370,00																		
Ø cm	COD.	BO	COD.	NM	€ - Eur																																													
130	2PNCT130-BO		2PNCT130-NM		4.440,00																																													
150	2PNCT150-BO		2PNCT150-NM		5.070,00																																													
Ø cm	COD.	AL	€ - Eur																																															
130	2PNCT130-AL		4.740,00																																															
150	2PNCT150-AL		5.370,00																																															
	<table border="1"> <thead> <tr> <th>L cm</th> <th>P cm</th> <th>COD.</th> <th>BO</th> <th>COD.</th> <th>NM</th> <th>€ - Eur</th> </tr> </thead> <tbody> <tr> <td>140</td> <td>140</td> <td>2PNCQ140140-BO</td> <td></td> <td>2PNCQ140140-NM</td> <td></td> <td>4.760,00</td> </tr> </tbody> </table>	L cm	P cm	COD.	BO	COD.	NM	€ - Eur	140	140	2PNCQ140140-BO		2PNCQ140140-NM		4.760,00	<table border="1"> <thead> <tr> <th>L cm</th> <th>P cm</th> <th>COD.</th> <th>AL</th> <th>€ - Eur</th> </tr> </thead> <tbody> <tr> <td>140</td> <td>140</td> <td>2PNCQ140140-AL</td> <td></td> <td>5.060,00</td> </tr> </tbody> </table>	L cm	P cm	COD.	AL	€ - Eur	140	140	2PNCQ140140-AL		5.060,00																								
L cm	P cm	COD.	BO	COD.	NM	€ - Eur																																												
140	140	2PNCQ140140-BO		2PNCQ140140-NM		4.760,00																																												
L cm	P cm	COD.	AL	€ - Eur																																														
140	140	2PNCQ140140-AL		5.060,00																																														
	<table border="1"> <thead> <tr> <th>L cm</th> <th>P cm</th> <th>COD.</th> <th>BO</th> <th>COD.</th> <th>NM</th> <th>€ - Eur</th> </tr> </thead> <tbody> <tr> <td>200</td> <td>100</td> <td>2PNCS200100-BO</td> <td></td> <td>2PNCS200100-NM</td> <td></td> <td>4.980,00</td> </tr> <tr> <td>240</td> <td>110</td> <td>2PNCS240110-BO</td> <td></td> <td>2PNCS240110-NM</td> <td></td> <td>5.970,00</td> </tr> <tr> <td>300</td> <td>120</td> <td>2PNCS300120-BO</td> <td></td> <td>2PNCS300120-NM</td> <td></td> <td>7.370,00</td> </tr> </tbody> </table>	L cm	P cm	COD.	BO	COD.	NM	€ - Eur	200	100	2PNCS200100-BO		2PNCS200100-NM		4.980,00	240	110	2PNCS240110-BO		2PNCS240110-NM		5.970,00	300	120	2PNCS300120-BO		2PNCS300120-NM		7.370,00	<table border="1"> <thead> <tr> <th>L cm</th> <th>P cm</th> <th>COD.</th> <th>AL</th> <th>€ - Eur</th> </tr> </thead> <tbody> <tr> <td>200</td> <td>100</td> <td>2PNCS200100-AL</td> <td></td> <td>5.290,00</td> </tr> <tr> <td>240</td> <td>110</td> <td>2PNCS240110-AL</td> <td></td> <td>6.410,00</td> </tr> <tr> <td>300</td> <td>120</td> <td>2PNCS300120-AL</td> <td></td> <td>7.810,00</td> </tr> </tbody> </table>	L cm	P cm	COD.	AL	€ - Eur	200	100	2PNCS200100-AL		5.290,00	240	110	2PNCS240110-AL		6.410,00	300	120	2PNCS300120-AL		7.810,00
L cm	P cm	COD.	BO	COD.	NM	€ - Eur																																												
200	100	2PNCS200100-BO		2PNCS200100-NM		4.980,00																																												
240	110	2PNCS240110-BO		2PNCS240110-NM		5.970,00																																												
300	120	2PNCS300120-BO		2PNCS300120-NM		7.370,00																																												
L cm	P cm	COD.	AL	€ - Eur																																														
200	100	2PNCS200100-AL		5.290,00																																														
240	110	2PNCS240110-AL		6.410,00																																														
300	120	2PNCS300120-AL		7.810,00																																														
	<table border="1"> <thead> <tr> <th>L cm</th> <th>P cm</th> <th>COD.</th> <th>BO</th> <th>COD.</th> <th>NM</th> <th>€ - Eur</th> </tr> </thead> <tbody> <tr> <td>200</td> <td>90</td> <td>2PNCR20090-BO</td> <td></td> <td>2PNCR20090-NM</td> <td></td> <td>4.740,00</td> </tr> <tr> <td>240</td> <td>100</td> <td>2PNCR240100-BO</td> <td></td> <td>2PNCR240100-NM</td> <td></td> <td>5.740,00</td> </tr> <tr> <td>300</td> <td>120</td> <td>2PNCR300120-BO</td> <td></td> <td>2PNCR300120-NM</td> <td></td> <td>7.160,00</td> </tr> </tbody> </table>	L cm	P cm	COD.	BO	COD.	NM	€ - Eur	200	90	2PNCR20090-BO		2PNCR20090-NM		4.740,00	240	100	2PNCR240100-BO		2PNCR240100-NM		5.740,00	300	120	2PNCR300120-BO		2PNCR300120-NM		7.160,00	<table border="1"> <thead> <tr> <th>L cm</th> <th>P cm</th> <th>COD.</th> <th>AL</th> <th>€ - Eur</th> </tr> </thead> <tbody> <tr> <td>200</td> <td>90</td> <td>2PNCR20090-AL</td> <td></td> <td>5.050,00</td> </tr> <tr> <td>240</td> <td>100</td> <td>2PNCR240100-AL</td> <td></td> <td>6.180,00</td> </tr> <tr> <td>300</td> <td>120</td> <td>2PNCR300120-AL</td> <td></td> <td>7.800,00</td> </tr> </tbody> </table>	L cm	P cm	COD.	AL	€ - Eur	200	90	2PNCR20090-AL		5.050,00	240	100	2PNCR240100-AL		6.180,00	300	120	2PNCR300120-AL		7.800,00
L cm	P cm	COD.	BO	COD.	NM	€ - Eur																																												
200	90	2PNCR20090-BO		2PNCR20090-NM		4.740,00																																												
240	100	2PNCR240100-BO		2PNCR240100-NM		5.740,00																																												
300	120	2PNCR300120-BO		2PNCR300120-NM		7.160,00																																												
L cm	P cm	COD.	AL	€ - Eur																																														
200	90	2PNCR20090-AL		5.050,00																																														
240	100	2PNCR240100-AL		6.180,00																																														
300	120	2PNCR300120-AL		7.800,00																																														

Colore struttura
Frame color



NM
Nero micaceo.
Micaceous black.
Noir micacé.
Negro micáceo.
Schwarz glimmerhaltig.



BO
Bianco opaco.
Mat white.
Blanc opaque.
Blanco mate.
Mattweiss.



AL
Alluminio lucidato.
Polished aluminium.
Aluminium poli.
Aluminio brillante.
Poliertes Aluminium.

Piano: finitura Noce Canaletto
Tabletop: Canaletto walnut finish
Plateau: finition noyer Canaletto
Tablero: finición nogal Canaletto
Tischplatte: Canaletto-Nussbaum Optik



Dettaglio piano
Detail tabletop



Per i tavoli **Pegaso Cemento, Pegaso Solid, Pegaso Metal e Pegaso Wood**, considerata la produzione artigianale e la finitura a mano, è richiesto un anticipo del 30% del valore al momento dell'ordine. Un anticipo del 30% del valore al momento dell'ordine è richiesto in caso di piano modificato per l'inserimento del passacavi per tutti i tavoli Pegaso Cemento, Pegaso Solid e Pegaso Metal.

Considering the artisanal production and the handmade finish, please consider a 30% payment in advance when ordering **Pegaso Cemento, Pegaso Solid, Pegaso Metal and Pegaso Wood** tables. Please consider a 30% payment in advance when ordering all Pegaso Cement, Pegaso Solid and Pegaso Metal tables if modified with cable management.

Pour les tables **Pegaso Cemento, Pegaso Solid, Pegaso Metal et Pegaso Wood**, en considération de la production artisanal et la finition manuelle, on demande un acompte du 30% au moment de la commande. On demande un acompte du 30% au moment de la commande en cas de plateau modifié pour l'ajoute des passe-cables pour toutes les tables Pegaso Cemento, Pegaso Solid et Pegaso Metal.

Considerando la producción artesanal y el acabado hecho a mano, se requiere un pago por adelantado del 30% al efectuar un pedido de las mesas **Pegaso Cemento, Pegaso Solid, Pegaso Metal y Pegaso Wood**. Se requiere un pago por adelantado del 30% al efectuar un pedido en caso de modifica de el sobre para l inserción de pasacable para todas las mesas Pegaso Cemento, Pegaso Solid y Pegaso Metal.

Da die **Pegaso Cemento, Pegaso Solid, Pegaso Metal und Pegaso Wood** Tischplatten in Einzelanfertigung in Handarbeit hergestellt werden ersuchen wir um 30% Anzahlung bei Bestellung der Tische. Wir ersuchen um 30% Anzahlung bei Bestellung für Pegaso Cemento, Pegaso Solid und Pegaso Metal Tische mit modifizierten Tischplatten (mit Kabelführung).

Nei piani dei tavoli **PEGASO CEMENTO, PEGASO SOLID, PEGASO METAL E PEGASO WOOD** possono essere inseriti i passacavi.

Per l'acquisto dei piani Cemento, Solid o Metal con i passacavi inseriti, contattare il nostro ufficio commerciale al numero 0362 491001.

Cable holders can be inserted within **PEGASO CEMENTO, PEGASO SOLID, PEGASO METAL AND PEGASO WOOD** tops.

Please contact our export department (+39 0362 491002) for ordering CEMENT, SOLID or METAL tops equipped with cable holders.

Dans les plateaux des tables **PEGASO CEMENTO, PEGASO SOLID, PEGASO METAL ET PEGASO WOOD** on peut insérer des passe-cables.

Pour acheter les plateaux Cemento, Solid et Metal avec passe-cables contacter notre s.ce commercial au +39-0362-491002.

Los sujeta cables pueden ser insertados en los tableros de **PEGASO CEMENTO, PEGASO SOLID, PEGASO METAL Y PEGASO WOOD**.



Por favor contactar con nuestro dept. export para pedir los tableros Cement, Solid y Metal equipados con los sujeta cables.

Kabelführungen können in die **PEGASO CEMENTO, PEGASO SOLID, PEGASO METAL UND PEGASO WOOD** Tischplatten integriert werden.



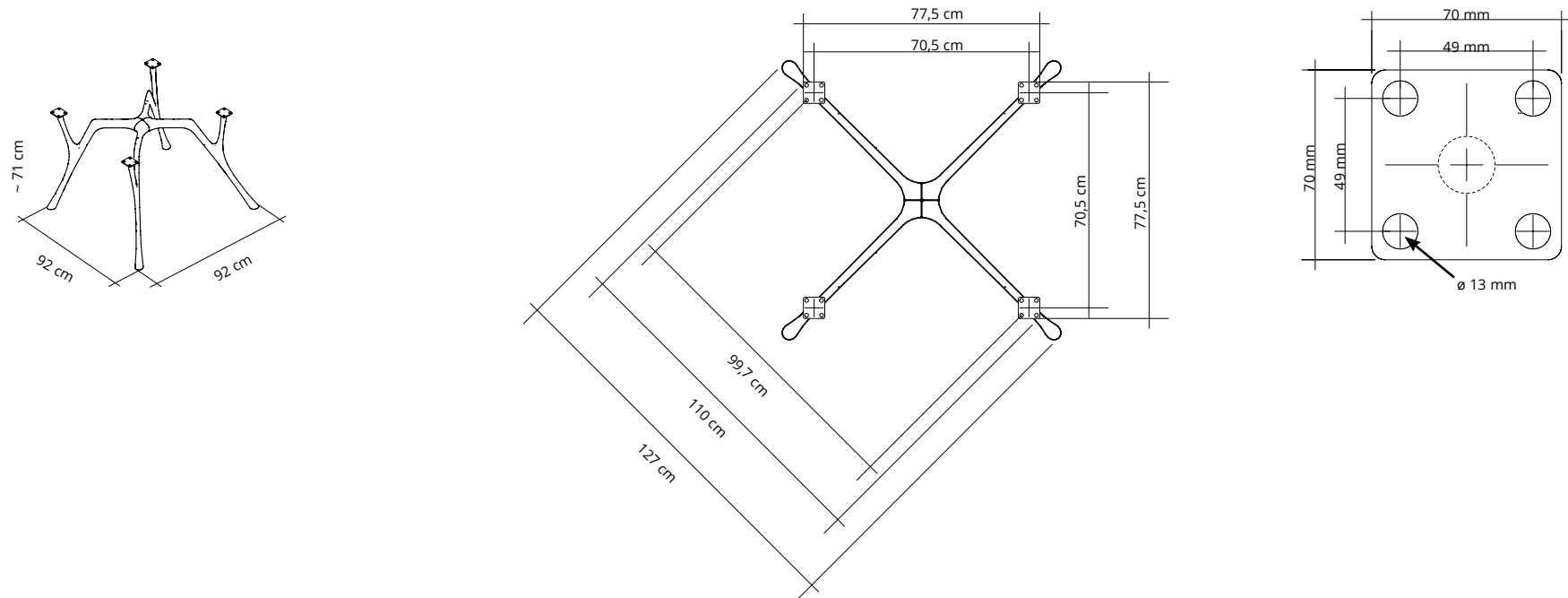



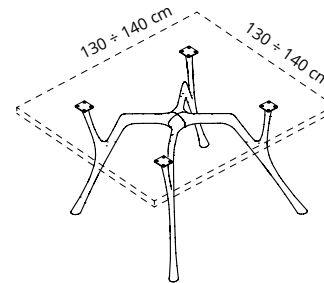
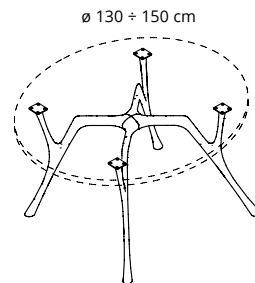

Bitte kontaktieren Sie unsere Exportabteilung (+39 0362 491002) für die Bestellung von CEMENTO, SOLID und METAL Tischplatten mit Kabelführung.

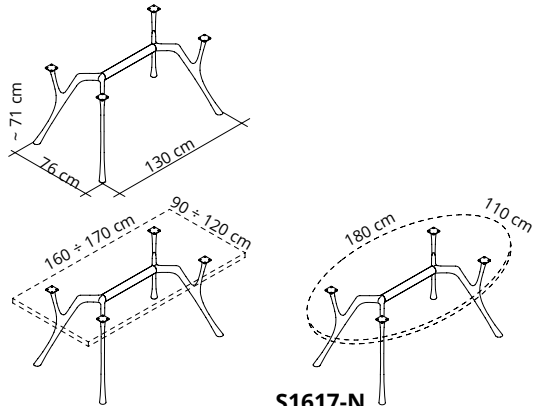
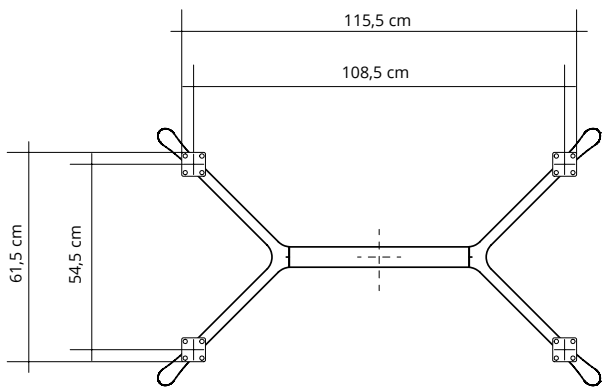
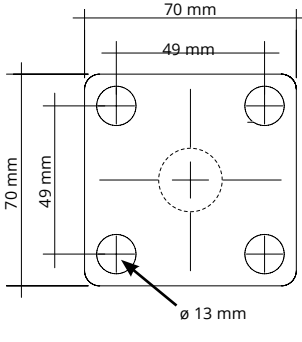

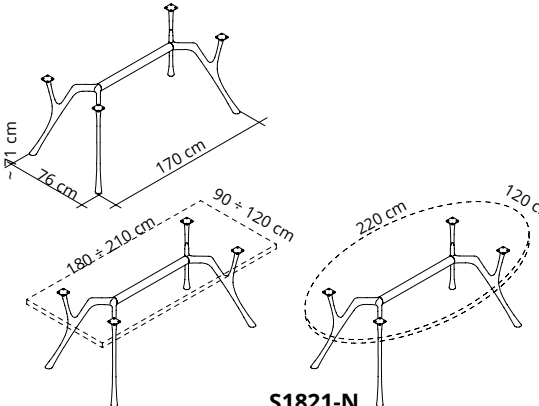
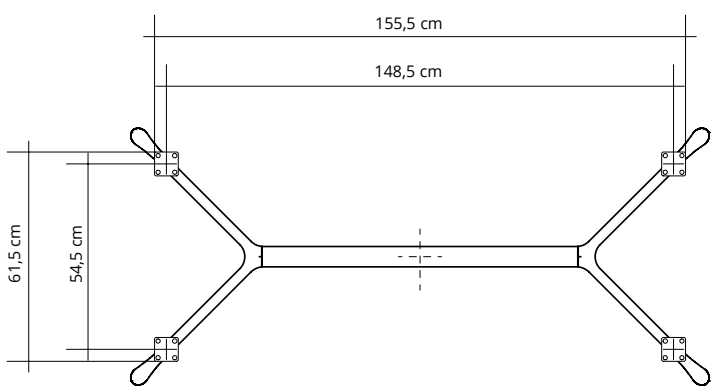
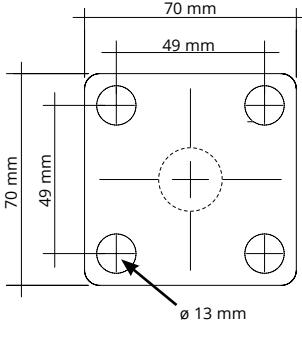

CD.	S1315-N	S1315-BO	S1315-AL
PR.	€ 1.280,00	€ 1.280,00	€ 1.580,00
CL.	 <p>NM Nero micaceo Micaceous black Noir micacé Negro micaceo Schwarz glimmerhaltig</p>	 <p>BO Bianco opaco Mat white Blanc opaque Blanco mate Mattweiss</p>	 <p>AL Alluminio lucidato Polished aluminum Aluminium poli Aluminio brillante Poliertes Aluminium</p>
DS.	<p>Struttura in fusione di alluminio lucidato o verniciato per tavoli con piani serie Solid/Cemento/Metal, quadrati o tondi, completa di 4 piastre in acciaio per il fissaggio del piano. Polished or powder-coated die-cast aluminum frame for squared or round top Solid/Cemento/Metal tables equipped with 4 steel plates for top fixation. Structure en aluminium moulé sous pression poli ou peint pour plateaux cadrés ou ronds des tables Solid/Cemento/Metal, équipée avec 4 platines en acier pour la fixation du plateau. Estructura en aluminio a presión brillante o barnizado para plazas o rondas planos de las mesas Solid/Cemento/Metal, completa de 4 placas de acero para fijar el plano. Poliertes oder pulverbeschichtetes Untergestell aus Aluminium für eckige oder runde Tischplatten, komplett mit 4 Montageplatten aus Stahl zur Befestigung der Tischplatten Cemento/Solid/Metal.</p>		



 <p>S1617-N</p>	 <p>S1617-BO</p>	 <p>S1617-AL</p>
<p>CD. € 1.360,00</p>	<p>CD. € 1.360,00</p>	<p>CD. € 1.670,00</p>
<p>CL.  NM Nero micaceo Micaceous black Noir micacé Negro micaceo Schwarz gimmerhaltig</p>	<p>CL.  BO Bianco opaco Mat white Blanc opaque Blanco mate Mattweiss</p>	<p>CL.  AL Alluminio lucidato Polished aluminum Aluminium poli Aluminio brillante Poliertes Aluminium</p>
<p>DS. Struttura in fusione di alluminio lucidato o verniciato per tavoli con piani serie Solid/Cemento/Metal, rettangolari o ovali, completa di 4 piastre in acciaio per il fissaggio del piano. Polished or powder-coated die-cast aluminum frame for rectangular or ovals top Solid/Cemento/Metal tables equipped with 4 steel plates for top fixation. Structure en aluminium moulé sous pression poli ou peint pour plateaux rectangulaires ou ovales des tables Solid/Cemento/Metal, équipée avec 4 platines en acier pour la fixation du plateau. Estructura en aluminio a presión brillante o barnizado para rectangular o óvalos planos de las mesas Solid/Cemento/Metal, completa de 4 placas de acero para fijar el plano. Poliertes oder pulverbeschichtetes Untergestell aus Aluminium für rechteckige oder ovale Tischplatten, komplett mit 4 Montageplatten aus Stahl zur Befestigung der Tischplatten Cemento/Solid/Metal.</p>		
 <p>S1821-N</p>	 <p>S1821-BO</p>	 <p>S1821-AL</p>
<p>CD. € 1.380,00</p>	<p>CD. € 1.380,00</p>	<p>CD. € 1.690,00</p>
<p>CL.  NM Nero micaceo Micaceous black Noir micacé Negro micaceo Schwarz gimmerhaltig</p>	<p>CL.  BO Bianco opaco Mat white Blanc opaque Blanco mate Mattweiss</p>	<p>CL.  AL Alluminio lucidato Polished aluminum Aluminium poli Aluminio brillante Poliertes Aluminium</p>
<p>DS. Struttura in fusione di alluminio lucidato o verniciato per tavoli con piani serie Solid/Cemento/Metal, rettangolari o ovali, completa di 4 piastre in acciaio per il fissaggio del piano. Polished or powder-coated die-cast aluminum frame for rectangular or ovals top Solid/Cemento/Metal tables equipped with 4 steel plates for top fixation. Structure en aluminium moulé sous pression poli ou peint pour plateaux rectangulaires ou ovales des tables Solid/Cemento/Metal, équipée avec 4 platines en acier pour la fixation du plateau. Estructura en aluminio a presión brillante o barnizado para rectangular o óvalos planos de las mesas Solid/Cemento/Metal, completa de 4 placas de acero para fijar el plano. Poliertes oder pulverbeschichtetes Untergestell aus Aluminium für rechteckige oder ovale Tischplatten, komplett mit 4 Montageplatten aus Stahl zur Befestigung der Tischplatten Solid/Cemento/Metal.</p>		

CD.	S2224-N	S2224-BO	S2224-AL
PR.	€ 1.580,00	€ 1.580,00	€ 2.020,00
CL.	<p>NM Nero micaceo Micaceous black Noir micacé Negro micaceo Schwarz gimmerhaltig</p>	<p>BO Bianco opaco Mat white Blanc opaque Blanco mate Mattweiss</p>	<p>AL Alluminio lucidato Polished aluminum Aluminium poli Aluminio brillante Poliertes Aluminium</p>
DS.	<p>Struttura in fusione di alluminio lucidato o verniciato per tavoli con piani serie Solid/Cemento/Metal, rettangolari, completa di 5 piastre in acciaio per il fissaggio del piano. Polished or powder-coated die-cast aluminum frame for rectangular top Solid/Cemento/Metal tables equipped with 5 steel plates for top fixation.</p> <p>Structure en aluminium moulé sous pression poli ou peint pour plateaux rectangulaires des tables Solid/Cemento/Metal, équipée avec 5 platines en acier pour la fixation du plateau.</p> <p>Estructura en aluminio a presión brillante o barnizado para rectangular planos de las mesas Solid/Cemento/Metal, completa de 5 placas de acero para fijar el plano.</p> <p>Poliertes oder pulverbeschichtetes Untergestell aus Aluminium für rechteckige Tischplatten, komplett mit 5 Montageplatten aus Stahl zur Befestigung der Tischplatten Solid/Cemento/Metal.</p>		
CD.	S2527-N	S2527-BO	S2527-AL
PR.	€ 1.600,00	€ 1.600,00	€ 2.040,00
CL.	<p>NM Nero micaceo Micaceous black Noir micacé Negro micaceo Schwarz gimmerhaltig</p>	<p>BO Bianco opaco Mat white Blanc opaque Blanco mate Mattweiss</p>	<p>AL Alluminio lucidato Polished aluminum Aluminium poli Aluminio brillante Poliertes Aluminium</p>
DS.	<p>Struttura in fusione di alluminio lucidato o verniciato per tavoli con piani serie Solid/Cemento/Metal, rettangolari, completa di 5 piastre in acciaio per il fissaggio del piano. Polished or powder-coated die-cast aluminum frame for rectangular top Solid/Cemento/Metal tables equipped with 5 steel plates for top fixation.</p> <p>Structure en aluminium moulé sous pression poli ou peint pour plateaux rectangulaires des tables Solid/Cemento/Metal, équipée avec 5 platines en acier pour la fixation du plateau.</p> <p>Estructura en aluminio a presión brillante o barnizado para rectangular planos de las mesas Solid/Cemento/Metal, completa de 5 placas de acero para fijar el plano.</p> <p>Poliertes oder pulverbeschichtetes Untergestell aus Aluminium für rechteckige Tischplatten, komplett mit 5 Montageplatten aus Stahl zur Befestigung der Tischplatten Solid/Cemento/Metal.</p>		

CD.	S2830-N	S2830-BO	S2830-AL
PR.	€ 1.620,00	€ 1.620,00	€ 2.060,00
CL.	<p>NM Nero micaceo Micaceous black Noir micacé Negro micaceo Schwarz gimmerhaltig</p>	<p>BO Bianco opaco Mat white Blanc opaque Blanco mate Mattweiss</p>	<p>AL Alluminio lucidato Polished aluminum Aluminium poli Aluminio brillante Poliertes Aluminium</p>
DS.	<p>Struttura in fusione di alluminio lucidato o verniciato per tavoli con piani serie Solid/Cemento/Metal, rettangolari, completa di 5 piastre in acciaio per il fissaggio del piano. Polished or powder-coated die-cast aluminum frame for rectangular top Solid/Cemento/Metal tables equipped with 5 steel plates for top fixation. Structure en aluminium moulé sous pression poli ou peint pour plateaux rectangulaires des tables Solid/Cemento/Metal, équipée avec 5 platines en acier pour la fixation du plateau. Estructura en aluminio a presion brillante o barnizado para rectangular planos de las mesas Solid/Cemento/Metal, completa de 5 placas de acero para fijar el plano. Poliertes oder pulverbeschichtetes Untergestell aus Aluminium für rechteckige Tischplatten, komplett mit 5 Montageplatten aus Stahl zur Befestigung der Tischplatten Solid/Cemento/Metal.</p>		
CD.	S3436-N	S3436-BO	S3436-AL
PR.	€ 1.640,00	€ 1.640,00	€ 2.080,00
CL.	<p>NM Nero micaceo Micaceous black Noir micacé Negro micaceo Schwarz gimmerhaltig</p>	<p>BO Bianco opaco Mat white Blanc opaque Blanco mate Mattweiss</p>	<p>AL Alluminio lucidato Polished aluminum Aluminium poli Aluminio brillante Poliertes Aluminium</p>
DS.	<p>Struttura in fusione di alluminio lucidato o verniciato per tavoli con piani serie Solid/Cemento/Metal, rettangolari, completa di 5 piastre in acciaio per il fissaggio del piano. Polished or powder-coated die-cast aluminum frame for rectangular top Solid/Cemento/Metal tables equipped with 5 steel plates for top fixation. Structure en aluminium moulé sous pression poli ou peint pour plateaux rectangulaires des tables Solid/Cemento/Metal, équipée avec 5 platines en acier pour la fixation du plateau. Estructura en aluminio a presion brillante o barnizado para rectangular planos de las mesas Solid/Cemento/Metal, completa de 5 placas de acero para fijar el plano. Poliertes oder pulverbeschichtetes Untergestell aus Aluminium für rechteckige Tischplatten, komplett mit 5 Montageplatten aus Stahl zur Befestigung der Tischplatten Solid/Cemento/Metal.</p>		

Piano in vetro trasparente.
Transparent glass desk-top.
Dessus en verre transparent.
Plano en vidrio transparente.
Tischplatte aus transparentem Glas.

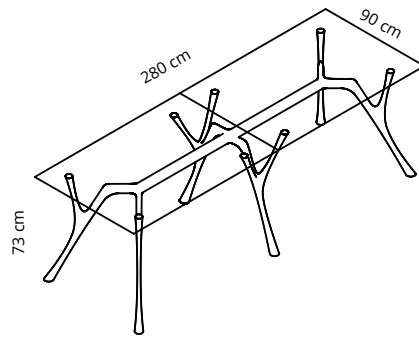

2PI28090-AL

€ 4.990,00

AL

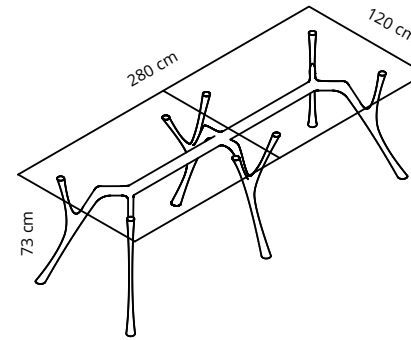

2PI280120-AL

€ 5.590,00

AL

CD.

PR.

CL.

DS.

Tavolo con struttura in fusione di alluminio lucidato. Piano in vetro temperato e molato trasparente spessore 12 mm. MODULO BASE.
Table with polished die-cast aluminum frame. Transparent tempered ground glass desktop, thickness 12 mm. BASIC MODULE.
Table avec structure en aluminium poli moulé sous pression. Dessus en verre trempé et biseauté, transparent, épaisseur 12 mm. MODULE DE BASE.
Armazón de mesa con acabado en aluminio pulido. Sobre en cristal transparente atemperado, espesor 12 mm. MODULO BASICO.
Tisch mit poliertem Untergestell aus Aluguss. Transparente Tischplatte aus gehärtetem Glas, Stärke 12 mm. BASIS MODUL.

Piano in vetro trasparente.
Transparent glass desk-top.
Dessus en verre transparent.
Plano en vidrio transparente.
Tischplatte aus transparentem Glas.

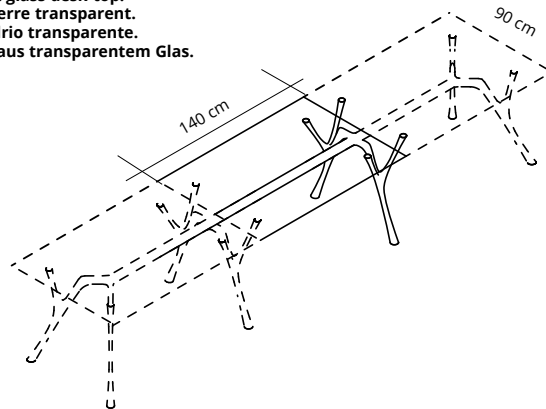

2PIS14090-AL

€ 2.490,00

AL

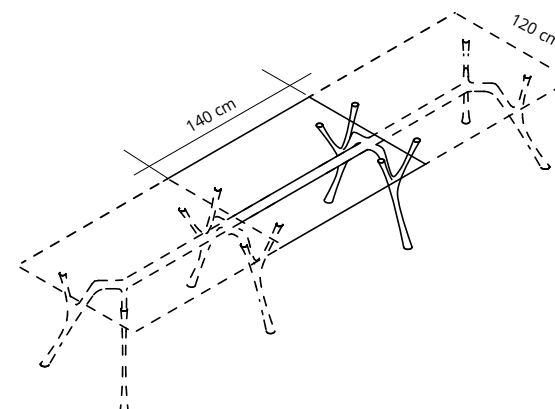

2PIS140120-AL

€ 2.790,00

AL

CD.

PR.

CL.

DS.

Tavolo con struttura in fusione di alluminio lucidato. Piano in vetro temperato e molato trasparente spessore 12 mm. MODULO INTERMEDIO - I moduli intermedi possono essere inseriti tra i due moduli base nella quantità desiderata.
Table with polished die-cast aluminum frame. Transparent tempered and ground glass desktop, thickness 12 mm. MIDDLE MODULE - Middle modules can be inserted between two basic modules in the desired quantity.
Table avec structure en aluminium poli moulé sous pression. Dessus en verre trempé et biseauté, transparent, épaisseur 12 mm. MODULE INTERMEDIAIRE - Les modules intermédiaires peuvent être insérés dans la quantité désirée entre les deux modules de base.
Armazón de mesa con acabado en aluminio pulido. Sobre en cristal transparente atemperado, espesor 12 mm. MODULO INTERMEDIO. Los módulos intermedios pueden ser insertados entre dos módulos básicos en las cantidades que se deseen.
Tisch mit poliertem Untergestell aus Aluguss. Transparente Tischplatte aus gehärtetem Glas, Stärke 12 mm. MITTLERES MODUL - Mittlere Module können zwischen zwei Basis Modulen in der gewünschten Menge eingesetzt werden.

Piano in vetro trasparente.
Transparent glass desk-top.
Dessus en verre transparent.
Plano en vidrio transparente.
Tischplatte aus transparentem Glas.

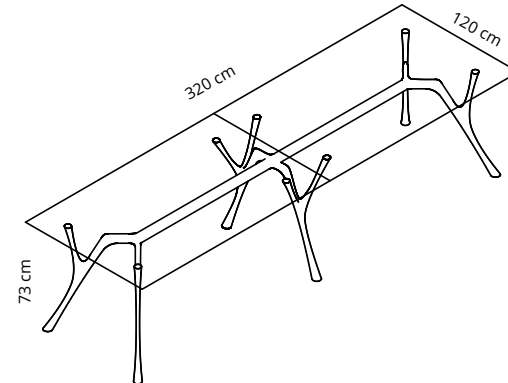
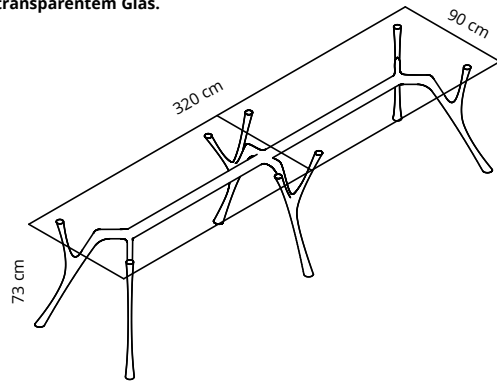

CD. **2PI32090-AL**
PR. **€ 5.330,00**
CL. AL

CD. **2PI320120-AL**
PR. **€ 5.930,00**
CL. AL

Tavolo con struttura in fusione di alluminio lucidato. Piano in vetro temperato e molato trasparente spessore 12 mm. MODULO BASE.
Table with polished die-cast aluminum frame. Transparent tempered ground glass desktop, thickness 12 mm. BASIC MODULE.
Table avec structure en aluminium poli moulé sous pression. Dessus en verre trempé et biseauté, transparent, épaisseur 12 mm. MODULE DE BASE.
Armazón de mesa con acabado en aluminio pulido. Sobre en cristal transparente atemperado, espesor 12 mm. MODULO BASICO.
Tisch mit poliertem Untergestell aus Aluguss. Transparente Tischplatte aus gehärtetem Glas, Stärke 12 mm. BASIS MODUL.

Piano in vetro trasparente.
Transparent glass desk-top.
Dessus en verre transparent.
Plano en vidrio transparente.
Tischplatte aus transparentem Glas.

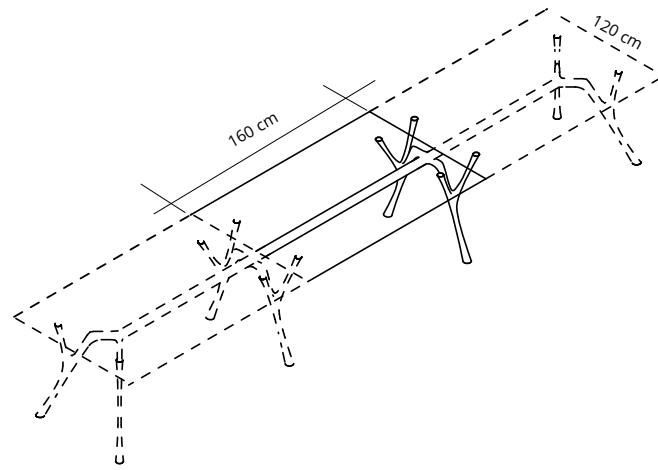
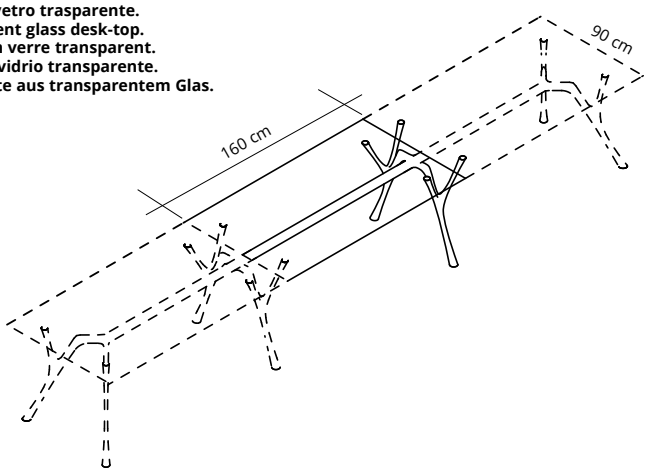

CD. **2PIS16090-AL**
PR. **€ 2.640,00**
CL. AL

CD. **2PIS160120-AL**
PR. **€ 2.940,00**
CL. AL

Tavolo con struttura in fusione di alluminio lucidato. Piano in vetro temperato e molato trasparente spessore 12 mm. MODULO INTERMEDIO - I moduli intermedi possono essere inseriti tra i due moduli base nella quantità desiderata.
Table with polished die-cast aluminum frame. Transparent tempered and ground glass desktop, thickness 12 mm. MIDDLE MODULE - Middle modules can be inserted between two basic modules in the desired quantity.
Table avec structure en aluminium poli moulé sous pression. Dessus en verre trempé et biseauté, transparent, épaisseur 12 mm. MODULE INTERMEDIAIRE - Les modules intermédiaires peuvent être insérés dans la quantité désirée entre les deux modules de base.
Armazón de mesa con acabado en aluminio pulido. Sobre en cristal transparente atemperado, espesor 12 mm. MODULO INTERMEDIO. Los módulos intermedios pueden ser insertados entre dos módulos básicos en las cantidades que se deseen.
Tisch mit poliertem Untergestell aus Aluguss. Transparente Tischplatte aus gehärtetem Glas, Stärke 12 mm. MITTLERES MODUL - Mittlere Module können zwischen zwei Basis Modulen in der gewünschten Menge eingesetzt werden.

Piano in vetro trasparente.
Transparent glass desk-top.
Dessus en verre transparent.
Plano en vidrio transparente.
Tischplatte aus transparentem Glas.

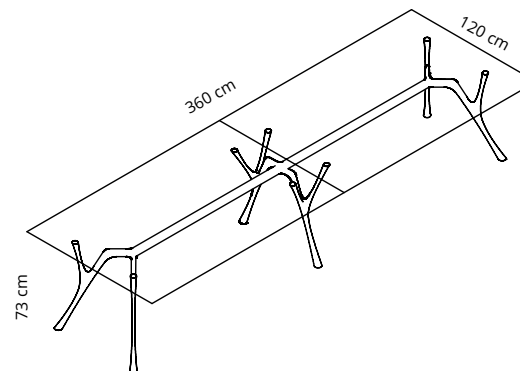
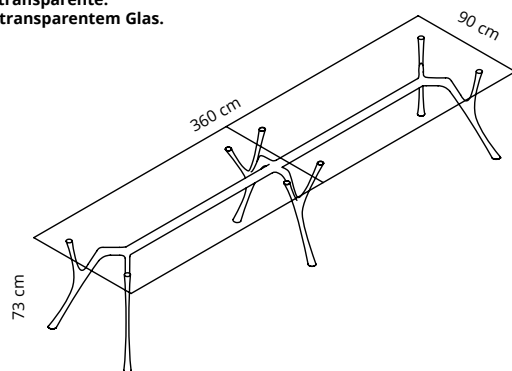

CD. **2PI36090-AL**

CD. **2PI360120-AL**

PR. **€ 5.970,00**

PR. **€ 5.980,00**

CL. AL

CL. AL

DS. Tavolo con struttura in fusione di alluminio lucidato. Piano in vetro temperato e molato trasparente spessore 12 mm. MODULO BASE.
Table with polished die-cast aluminum frame. Transparent tempered ground glass desktop, thickness 12 mm. BASIC MODULE.
Table avec structure en aluminium poli moulé sous pression. Dessus en verre trempé et biseauté, transparent, épaisseur 12 mm. MODULE DE BASE.
Armazón de mesa con acabado en aluminio pulido. Sobre en cristal transparente atemperado, espesor 12 mm. MODULO BASICO.
Tisch mit poliertem Untergestell aus Aluguss. Transparente Tischplatte aus gehärtetem Glas, Stärke 12 mm. BASIS MODUL.

Piano in vetro trasparente.
Transparent glass desk-top.
Dessus en verre transparent.
Plano en vidrio transparente.
Tischplatte aus transparentem Glas.

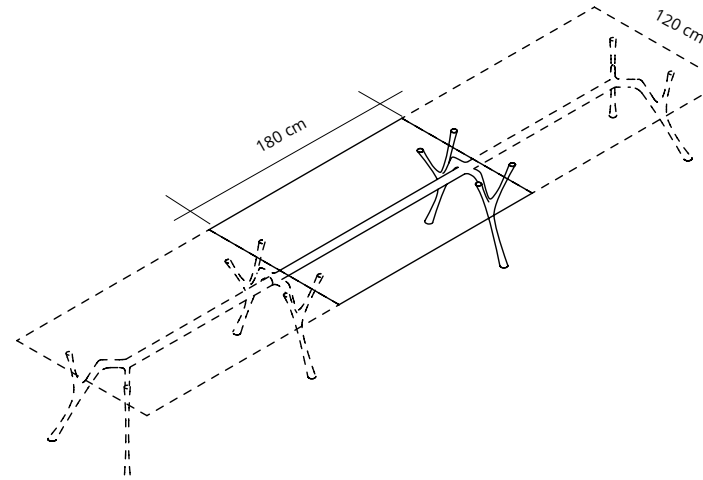
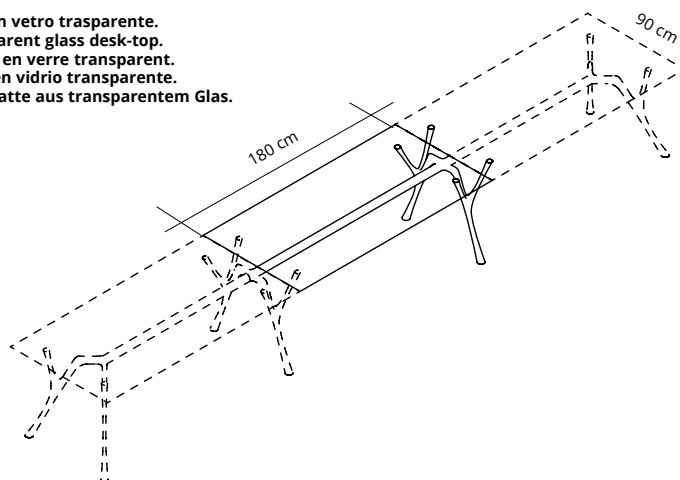

CD. **2PIS18090-AL**

CD. **2PIS180120-AL**

PR. **€ 2.790,00**





PR. **€ 2.980,00**

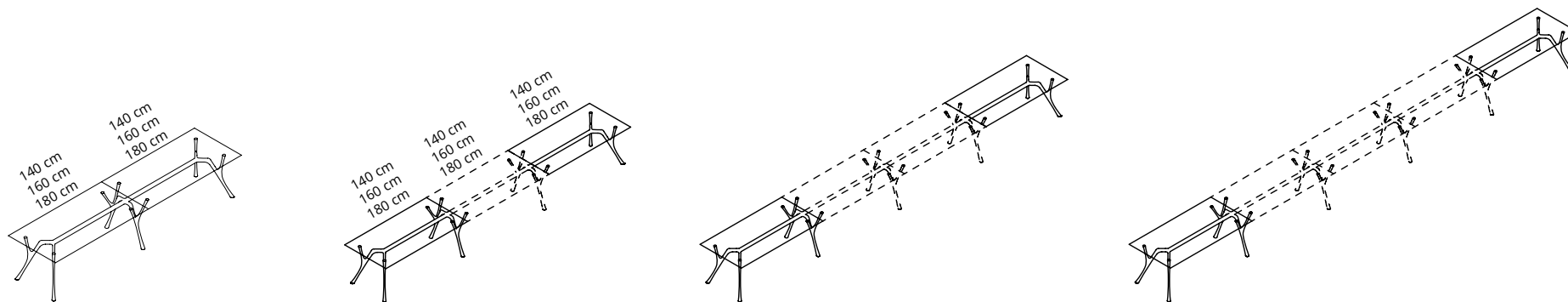

CL. AL

CL. AL

DS. Tavolo con struttura in fusione di alluminio lucidato. Piano in vetro temperato e molato trasparente spessore 12 mm. MODULO INTERMEDIO - I moduli intermedi possono essere inseriti tra i due moduli base nella quantità desiderata.
Table with polished die-cast aluminum frame. Transparent tempered and ground glass desktop, thickness 12 mm. MIDDLE MODULE - Middle modules can be inserted between two basic modules in the desired quantity.
Table avec structure en aluminium poli moulé sous pression. Dessus en verre trempé et biseauté, transparent, épaisseur 12 mm. MODULE INTERMEDIAIRE - Les modules intermédiaires peuvent être insérés dans la quantité désirée entre les deux modules de base.
Armazón de mesa con acabado en aluminio pulido. Sobre en cristal transparente atemperado, espesor 12 mm. MODULO INTERMEDIO. Los módulos intermedios pueden ser insertados entre dos módulos básicos en las cantidades que se deseen.
Tisch mit poliertem Untergestell aus Aluguss. Transparente Tischplatte aus gehärtetem Glas, Stärke 12 mm. MITTLERES MODUL - Mittlere Module können zwischen zwei Basis Modulen in der gewünschten Menge eingesetzt werden.

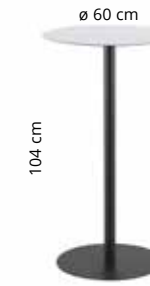

							
CD.	2JH65-NNL	2JH67-NNL	2JH610-NNL		2JH65-NB	2JH67-NB	2JH610-NB
PR.	€ 367,00	€ 385,00	€ 398,00		€ 347,00	€ 365,00	€ 378,00
CL.	N	N	N		N	N	N

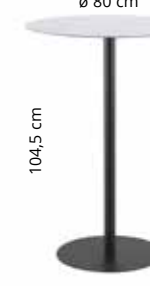

			
	2JH85-NB	2JH87-NB	2JH810-NB
	€ 557,00	€ 575,00	€ 588,00
	N	N	N

Tavolino con struttura verniciata nero e piano in HPL nero lava.
 Coffee table with black powder-coated frame and black lava HPL top.
 Petite table avec structure peinte noir et plateau en HPL noir lave.
 Mesita con estructura recubierta negro y plano en HPL negro lava.
 Tischchen mit schwarz pulverbeschichtetem Untergestell und Tischplatte aus lavaschwarzem HPL.



Tavolino con struttura verniciata nero e piano in HPL bianco.
 Coffee table with black powder-coated frame and white HPL top.
 Petite table avec structure peinte noir et plateau en HPL blanc.
 Mesita con estructura recubierta negro y plano en HPL blanco.
 Tischchen mit schwarz pulverbeschichtetem Untergestell und Tischplatte aus weißem HPL.



	 <p>55 cm ø 60 cm</p>	 <p>73,5 cm ø 60 cm</p>	 <p>105,5 cm ø 60 cm</p>
CD.	2JV65-TN	2JV67-TN	2JV610-TN
PR.	€ 447,00	€ 465,00	€ 478,00
CL.	N	N	N

DS.

Tavolino con struttura verniciata nero e piano in vetro trasparente.
 Coffee table with black powder-coated frame and transparent glass top.
 Petite table avec structure peinte noir et plateau en verre transparent.
 Mesita con estructura recubierta negro y plano en vidrio transparente.
 Tischchen mit schwarz pulverbeschichtetem Untergestell und Tischplatte aus transparentem Glas.



						
CD.	2JH65-INL	2JH67-INL	2JH610-INL	2JH65-IB	2JH67-IB	2JH610-IB
PR.	€ 417,00	€ 435,00	€ 448,00	€ 397,00	€ 415,00	€ 428,00
CL.						

			
CD.	2JH85-IB	2JH87-IB	2JH810-IB
PR.	€ 607,00	€ 625,00	€ 636,00
CL.			

Tavolino con struttura cromata, base rivestita in acciaio inox e piano in HPL nero lava.
 Coffee table with chrome-plated frame, base covered with stainless steel and black lava HPL top.
 Petite table avec structure chromée, base revêtue en acier inox et plateau en HPL noir lave.
 Mesita con estructura cromada, base revestida de acero inox y plano en HPL negro lava.
 Tischchen mit verchromtem Untergestell, Bodenplatte mit rostfreiem Stahl ummantelt und Tischplatte aus lavaschwarzem HPL.



Tavolino con struttura cromata, base rivestita in acciaio inox e piano in HPL bianco.
 Coffee table with chrome-plated frame, base covered with stainless steel and white HPL top.
 Petite table avec structure chromée, base revêtue en acier inox et plateau en HPL blanc.
 Mesita con estructura cromada, base revestida de acero inox y plano en HPL blanco.
 Tischchen mit verchromtem Untergestell, Bodenplatte mit rostfreiem Stahl ummantelt und Tischplatte aus weißem HPL.





2JV65-TI



2JV67-TI



2JV610-TI

CD.

PR.

CL.







€ 497,00

€ 515,00

€ 528,00

Tavolino con struttura cromata, base rivestita in acciaio inox e piano in vetro trasparente.
 Coffee table with chrome-plated frame, base covered with stainless steel and transparent glass top.
 Petite table avec structure chromée, base revêtue en acier inox et plateau en verre transparent.
 Mesita con estructura cromada, base revestida de acero inox y plano en vidrio transparente.
 Tischchen mit verchromtem Untergestell, Bodenplatte mit rostfreiem Stahl ummantelt und Tischplatte aus transparentem Glas.

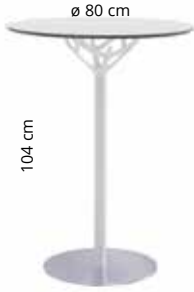

	 <p>49,5 cm ø 60 cm</p>	 <p>71,5 cm ø 60 cm</p>	 <p>103,5 cm ø 60 cm</p>
CD.	2CH65-BOB	2CH67-BOB	2CH610-BOB
PR.	€ 530,00	€ 535,00	€ 540,00
CL.	BO	BO	BO
	 <p>50 cm ø 80 cm</p>	 <p>72 cm ø 80 cm</p>	 <p>104 cm ø 80 cm</p>
CD.	2CH85-BOB	2CH87-BOB	2CH810-BOB
PR.	€ 730,00	€ 735,00	€ 740,00
CL.	BO	BO	BO
DS.	<p>Tavolino con struttura in acciaio e alluminio verniciati bianco opaco, base rivestita in acciaio inox e piano in HPL bianco. Small table with mat white powder-coated steel and aluminum frame, base covered with stainless steel and white HPL top. Petite table avec structure en acier et aluminium peints blanc mat, base revêtue en acier inox et plateau en HPL blanc. Mesita con estructura en acero y aluminio barnizados blanco mate, base revestida de acero inox y plano en HPL blanco. Tischchen mit mattweiß pulverbeschichtetem Stahl und Aluminium Untergestell, Bodenplatte mit rostfreiem Stahl ummantelt und Tischplatte aus weißem HPL</p> 		



CD.

2CV65-TBO

2CV67-TBO

2CV610-TBO

PR.

€ 630,00

€ 635,00

€ 640,00

CL.

BO

BO

BO

Tavolino con struttura in acciaio e alluminio verniciati bianco opaco, base rivestita in acciaio inox e piano in vetro trasparente.
 Small table with mat white powder-coated steel and aluminum frame, base covered with stainless steel and transparent glass top.
 Petite table avec structure en acier et aluminium peints blanc mat, base revêtue en acier inox et plateau en verre transparent.
 Mesita con estructura en acero y aluminio barnizados blanco mate, base revestida de acero inox y plano en vidrio transparente.
 Tischchen mit mattweiß pulverbeschichtetem Stahl und Aluminium Untergestell, Bodenplatte mit rostfreiem Stahl ummantelt und Tischplatte aus transparentem Glas.





2SH63-NNL

€ 495,00

N

Tavolino con struttura in tondino di acciaio e piano in HPL nero lava.
 Small table with frame steel rod and black lava HPL top.
 Petite table avec structure en fil d'acier et plateau en HPL noir lave.
 Mesita con estructura en hilo de acero y plano en HPL negro lava.
 Tischchen mit Stahldraht Untergestell und Tischplatte aus lavaschwarzem HPL.



2SH63-NB

€ 475,00

N

Tavolino con struttura in tondino di acciaio e piano in HPL bianco.
 Small table with frame steel rod and white HPL top.
 Petite table avec structure en fil d'acier et plateau en HPL blanc.
 Mesita con estructura en hilo de acero y plano en HPL blanco.
 Tischchen mit Stahldraht Untergestell und Tischplatte aus weissem HPL.

CD.

PR.

CL.

DS.

CD.

PR.

CL.

DS.



VERSATILE SEATING & SEATING

design

Sezgin Aksu

Stefano Barzaghi

Michele De Lucchi

Alessandro Mendini

I_Collezioni di sedute giocose e versatili che uniscono comfort e creatività. Ogni pezzo invita ad arredare lo spazio con uno stile elegante, ma informale, consentendo di riadattare con semplicità l'ambiente in base alle mutevoli esigenze quotidiane. La libertà di trasformare ogni seduta in un'esperienza unica. A completamento dell'offerta di sedute, troviamo le sedie e gli sgabelli Kaleidos, che attraverso una peculiare texture della seduta, si identificano quali soluzioni dal design essenziale e raffinato.

EN_Our playful and versatile seating collections combine comfort with creativity. Each piece invites one to add a touch of elegance and informality to a space, and can effortlessly adapt and re-adapt to daily needs. Enjoy the freedom to create a unique seating experience every time. Completing the seating offer are the Kaleidos chairs and stools, which, through a distinctive seat texture, identify themselves as solutions with an essential and refined design.

F_Des collections de sièges ludiques et polyvalents qui allient confort et créativité. Chaque élément vous invite à meubler l'espace avec un style à la fois élégant et informel, vous permettant de réajuster facilement vos espaces en fonction de l'évolution de vos besoins quotidiens. La liberté de transformer chaque siège en une expérience unique. Les chaises et les tabourets Kaleidos complètent l'offre de sièges. Grâce à la texture distinctive de leur assise, ils s'imposent comme des solutions au design essentiel et raffiné.

E_Colección de asientos divertidos y versátiles que conjugan confort y creatividad. Cada pieza aporta un toque de estilo elegante pero informal, que permite transformar el ambiente de manera sencilla adaptándose a las variables necesidades cotidianas. La libertad de convertir cada asiento en una experiencia única. Completan la oferta de asientos las sillas y taburetes Kaleidos, que, a través de una textura de asiento distintiva, se identifican como soluciones de diseño esencial y refinado.

D_Verspielte und vielseitige Sitzmöbelkolektionen, die Komfort und Kreativität in Einklang bringen. Jedes Stück lädt dazu ein, den Raum in elegantem und doch ungezwungenem Stil einzurichten, und ihn an die verschiedenen Bedürfnisse im Alltag anzupassen. Genießen Sie sich die Freiheit für ein einzigartiges Sitzenerlebnis. Das Angebot an Sitzgelegenheiten wird durch die Stühle und Hocker von Kaleidos vervollständigt, die sich durch ihre besondere Sitztextur als Lösungen mit einem essentiellen und raffinierten Design auszeichnen.



43 cm

ø 34,5 cm

18SM1-BO

CD.

PR.

CL.

€ 168,00

BO



43 cm

ø 34,5 cm

18SM1-AZ

€ 168,00

AZ



43 cm

ø 34,5 cm

18SM1-R

€ 168,00

R



43 cm

ø 34,5 cm

18SM1-GL

€ 168,00

GL



43 cm

ø 34,5 cm

18SM2-BO

CD.

PR.

CL.

€ 177,00

BO



43 cm

ø 34,5 cm

18SM2-AZ

€ 177,00

AZ



43 cm

ø 34,5 cm

18SM2-R

€ 177,00

R



43 cm

ø 34,5 cm

18SM2-GL

€ 177,00

GL



43 cm

34,5 cm 34,5 cm

18SM3-BO

CD.

PR.

CL.

€ 197,00

BO

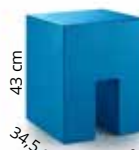

43 cm

34,5 cm 34,5 cm

18SM3-AZ

€ 197,00

AZ



43 cm

34,5 cm 34,5 cm

18SM3-R

€ 197,00

R



43 cm

34,5 cm 34,5 cm

18SM3-GL

€ 197,00

GL

DS.

Sgabelli / tavolini in polietilene riciclato al 30% con finitura satinata.
 Stools / coffee tables in 30% recycled polyethylene with satin finish.
 Tabourets / tables basses en polyéthylène recyclé à 30% avec finition satinée.
 Taburetes / mesas de centro de polietileno reciclado al 30% con acabado satinado.
 Hocker / Couchtische aus 30% recyceltem Polyethylen mit satinierter Oberfläche







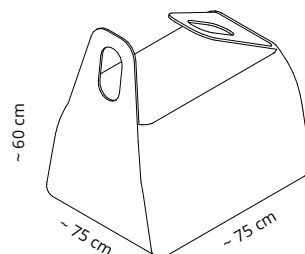

SOUND ABSORBING

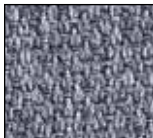

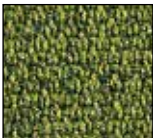

CD.	2SB1-300	2SB1-305	2SB1-309
PR.	€ 550,00	€ 550,00	€ 550,00
CL.	 300	 305	 309
DS.	<p>Pouf fonoassorbente con imbottitura interna in palline di polistirolo, rivestimento esterno in tessuto Snowsound-Fiber Textiles 3 Melange. Sound-absorbing pouf with interior polystyrene ball padding; external covering in Snowsound-Fiber Textiles 3 Melange. Pouf phono-absorbant avec rembourrage intérieur en boule de polystyrène, revêtement externe en tissu Snowsound-Fiber Textiles 3 Melange. Puf fonoabsorbente con acolchado interior de bolas de poliestireno, tapizada con tejido Snowsound-Fiber Textiles 3 Melange. Schallabsorbierendes Element mit Innenpolsterung aus Styroporkugeln, Außenbezug aus Snowsound-Fiber Textiles 3 Melange.</p>		

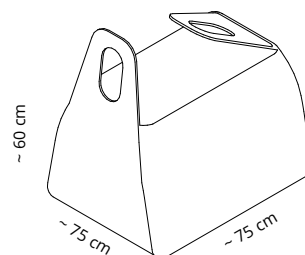

SOUND ABSORBING



CD.	2SB1-801	2SB1-812	2SB1-815
PR.	€ 650,00	€ 650,00	€ 650,00
CL.	 801	 812	 815
DS.	<p>Pouf fonoassorbente con imbottitura interna in palline di polistirolo, rivestimento esterno in tessuto Snowsound-Fiber Textiles 8 Bouclé. Sound-absorbing pouf with interior polystyrene ball padding; external covering in Snowsound-Fiber Textiles 8 Bouclé. Pouf phono-absorbant avec rembourrage intérieur en boule de polystyrène, revêtement externe en tissu Snowsound-Fiber Textiles 8 Bouclé. Puf fonoabsorbente con acolchado interior de bolas de poliestireno, tapizada con tejido Snowsound-Fiber Textiles 8 Bouclé. Schallabsorbierendes Element mit Innenpolsterung aus Styroporkugeln, Außenbezug aus Snowsound-Fiber Textiles 8 Bouclé.</p>		

Colori disponibili su richiesta / Colours available on request / Couleurs disponibles sur demande / Colores disponibles previa solicitud / Farben auf Anfrage erhältlich

SNOWSOUND FIBER 3 MELANGE

CODICE/CODE 2SB1-XXX (XXX = variante colore / color option) € 633,00

Tempo di consegna 5 settimane / Delivery time 5 weeks / Délai de livraison 5 semaines / Plazos de entrega 5 semanas / Lieferfrist 5 Wochen

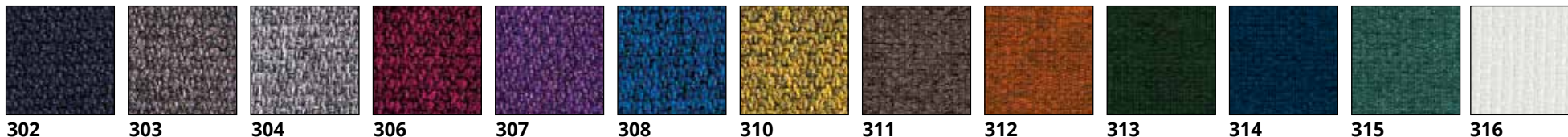

SNOWSOUND FIBER 8 BOUCLE'

CODICE/CODE 2SB1-XXX (XXX = variante colore / color option) € 748,00

Tempo di consegna 5 settimane / Delivery time 5 weeks / Délai de livraison 5 semaines / Plazos de entrega 5 semanas / Lieferfrist 5 Wochen

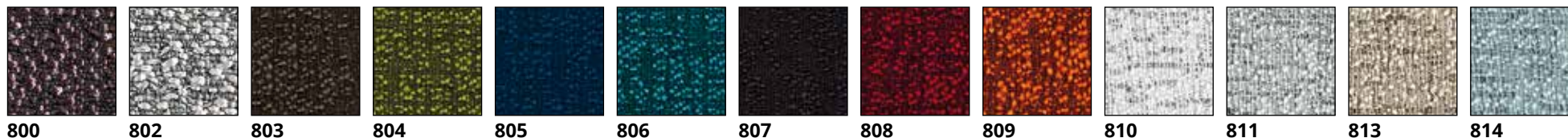

SNOWSOUND FIBER 12 ECONYL

CODICE/CODE 2SB1-XXXX (XXXX = variante colore / color option) € 757,00

Tempo di consegna 5 settimane / Delivery time 5 weeks / Délai de livraison 5 semaines / Plazos de entrega 5 semanas / Lieferfrist 5 Wochen

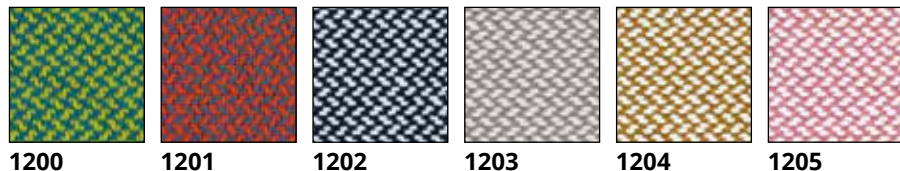







CD.	9K112-CGR	9K112-CBO	9K112-CN
PR.	€ 198,00 <small>cad each</small>	€ 238,00 <small>cad each</small>	€ 238,00 <small>cad each</small>
CL.	GR	B	N
	2 pz. per scatola Box of 2 pcs Condit. à 2 pcs 2 pz. por embalaje Verpackungseinheit 2 St.	2 pz. per scatola Box of 2 pcs Condit. à 2 pcs 2 pz. por embalaje Verpackungseinheit 2 St.	2 pz. per scatola Box of 2 pcs Condit. à 2 pcs 2 pz. por embalaje Verpackungseinheit 2 St.

DS.

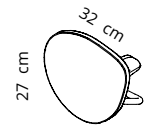
Seduta in tecnopolimero e struttura in acciaio cromato.
 High-tech polymer seat and chrome-plated steel frame.
 Assise en technopolymère et structure en acier chromé.
 Asiento en tecnopolimero y estructura en acero cromado.
 Sitzschale aus Technopolymer und Stuhlgestell aus verchromtem Stahl.

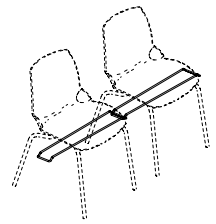
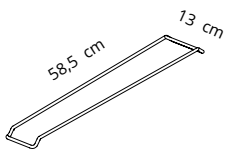

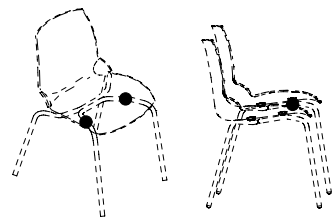
	 <p>Per strutture ø 16 mm. For frame ø 16 mm. Pour structure ø 16 mm. Para estructura ø 16 mm. Für Gestell ø 16 mm.</p> <p>* SX = Tavoletta sinistra Left tablet Tablette à gauche Tableta a la izquierda Linke Schreibplatte</p> 	
CD.	<p>9K17</p>	<p>9K17/SX *</p>
PR.	<p>€ 98,00 cad each</p>	<p>€ 98,00 cad each</p>
CL.	<p>N</p>	<p>N</p>
	<p>2 pz. per scatola Box of 2 pcs Condit. à 2 pcs 2 pz. por embalaje Verpackungseinheit 2 St.</p>	
DS.	<p>Tavoletta in tecnopolimero con supporto in acciaio cromato. High-tech polymer tablet with chrome-plated support. Tablette en technopolymère avec support en acier chromé. Tableta en tecnopolimero con soporte en acero cromado. Schreibplatte aus Technopolymer mit Halterung aus verchromtem Stahl.</p>	
	 <p>Per strutture ø 16 mm. For frame ø 16 mm. Pour structure ø 16 mm. Para estructura ø 16 mm. Für Gestell ø 16 mm.</p> 	 <p>max 6 pcs</p>  <p>Per strutture ø 16 mm. For frame ø 16 mm. Pour structure ø 16 mm. Para estructura ø 16 mm. Für Gestell ø 16 mm.</p>
CD.	<p>9K19</p>	<p>9K13</p>
PR.	<p>€ 42,00 cad each</p>	<p>€ 11,00</p>
CL.	<p>C</p>	<p>GR</p>
	<p>2 pz. per scatola Box of 2 pcs Condit. à 2 pcs 2 pz. por embalaje Verpackungseinheit 2 St.</p>	
DS.	<p>Attacco in linea in acciaio cromato. Chrome-plated linear connection. Connection linéaire en acier chromé. Connexion lineal en acero cromado. Reihenverbinder aus verchromtem Stahl.</p>	<p>2 coppie distanziali per sovrapposizione sedie (1 coppia per ogni sedia). 2 pairs of spacers for chairs stacking (1 pair for each chair). 2 paires d'espaces pour superposition des chaises (1 paire pour chaque chaise). 2 sets de distanciadores para apilar las sillas (1 set cada silla). 2 Paar Abstandhalter zum Stapeln der Stühle (1 Paar pro Stuhl).</p>



CD.	9K222-CGR	9K222-CBO	9K222-CN
PR.	€ 228,00 <small>cad each</small>	€ 268,00 <small>cad each</small>	€ 268,00 <small>cad each</small>
CL.	GR	B	N
	2 pz. per scatola Box of 2 pcs Condit. à 2 pcs 2 pz. por embalaje Verpackungseinheit 2 St.	2 pz. per scatola Box of 2 pcs Condit. à 2 pcs 2 pz. por embalaje Verpackungseinheit 2 St.	2 pz. per scatola Box of 2 pcs Condit. à 2 pcs 2 pz. por embalaje Verpackungseinheit 2 St.

DS. Seduta in tecnopolimero e struttura in acciaio cromato.
 High-tech polymer seat and chrome-plated steel frame.
 Assise en technopolymère et structure en acier chromé.
 Asiento en tecnopolimero y estructura en acero cromado.
 Sitzschale aus Technopolymer und Stuhlgestell aus verchromtem Stahl.



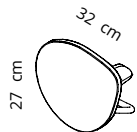

* SX =
Tavoletta sinistra
Left tablet
Tablette à gauche
Tableta a la izquierda
Linke Schreibplatte

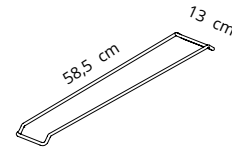
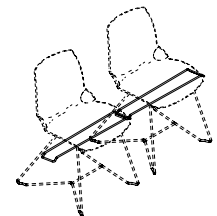

CD.	9K17	* SX = Tavoletta sinistra Left tablet Tablette à gauche Tableta a la izquierda Linke Schreibplatte	9K19
PR.	€ 98,00 <small>cad each</small>	€ 98,00 <small>cad each</small>	€ 42,00 <small>cad each</small>
CL.	N	N	C
	2 pz. per scatola Box of 2 pcs Condit. à 2 pcs 2 pz. por embalaje Verpackungseinheit 2 St.		2 pz. per scatola Box of 2 pcs Condit. à 2 pcs 2 pz. por embalaje Verpackungseinheit 2 St.
DS.	Tavoletta in tecnopolimero con supporto in acciaio cromato. High-tech polymer tablet with chrome-plated support. Tablette en technopolymère avec support en acier chromé. Tableta en tecnopolimero con suporto en acero cromado. Schreibplatte aus Technopolymer mit Halterung aus verchromtem Stahl.		Attacco in linea in acciaio cromato. Chrome-plated linear connection. Connection linéaire en acier chromé. Connexion lineal en acero cromado. Reihenverbinder aus verchromtem Stahl.

Non girevole
Non-swivel
Non pivotante
No giratoria
Nicht drehbar



CD.	9K402R-CGR	9K402R-CBO	9K402R-CN
PR.	€ 338,00 <small>cad each</small>	€ 368,00 <small>cad each</small>	€ 368,00 <small>cad each</small>
CL.	GR	B	N
	2 pz. per scatola Box of 2 pcs Condit. à 2 pcs 2 pz. por embalaje Verpackungseinheit 2 St.	2 pz. per scatola Box of 2 pcs Condit. à 2 pcs 2 pz. por embalaje Verpackungseinheit 2 St.	2 pz. per scatola Box of 2 pcs Condit. à 2 pcs 2 pz. por embalaje Verpackungseinheit 2 St.

DS. Seduta in tecnopolimero e struttura in acciaio cromato. 4 ruote. Non Girevole.
High-tech polymer seat and chrome-plated steel frame. 4 casters. Non-swivel.
Assise en technopolymère et structure en acier chromé. 4 roulettes. Non pivotante.
Asiento en tecnopolimero y estructura en acero cromado. 4 ruedas. No giratoria.
Sitzschale aus Technopolymer und Stuhlgestell aus verchromtem Stahl. 4 Rollen. Nicht drehbar.





CD.	9K672-CGR	9K672-CBO	9K672-CN
PR.	€ 278,00 <small>cad each</small>	€ 287,00 <small>cad each</small>	€ 287,00 <small>cad each</small>
CL.	GR	B	N
	2 pz. per scatola Box of 2 pcs Condit. à 2 pcs 2 pz. por embalaje Verpackungseinheit 2 St.	2 pz. per scatola Box of 2 pcs Condit. à 2 pcs 2 pz. por embalaje Verpackungseinheit 2 St.	2 pz. per scatola Box of 2 pcs Condit. à 2 pcs 2 pz. por embalaje Verpackungseinheit 2 St.

DS. Seduta in tecnopolimero e struttura in acciaio cromato.
 High-tech polymer seat and chrome-plated steel frame.
 Assise en technopolymère et structure en acier chromé.
 Asiento en tecnopolimero y estructura en acero cromado.
 Sitzschale aus Technopolymer und Stuhlgestell aus verchromtem Stahl.



PUBLIC SEATING

design

Sezgin Aksu

Caimi Lab

Michele De Lucchi

I Sedute per collettività eleganti e funzionali, adatte a diversi ambienti, dalle piccole alle grandi sale d'attesa. I materiali utilizzati sono facilmente pulibili e igienizzabili e, per tanto, particolarmente adatti ad ambienti con grande affluenza di pubblico.

EN Elegant and functional seating for public areas, suitable for different sorts of spaces, from small to large waiting rooms. The constituent materials are easy to clean and sanitize, and are therefore particularly suited to environments frequented by large numbers of people.

F Des sièges élégants et fonctionnels pour collectivités, appropriés aux différents types d'intérieurs, des petites aux grandes salles d'attente. Les matériaux utilisés sont faciles à nettoyer et à assainir et, par conséquent, particulièrement adaptés aux lieux très fréquentés.

E Bancadas elegantes y funcionales que se adaptan a diferentes ambientes, tanto a pequeñas como a grandes salas de espera. Los materiales empleados se limpian y desinfectan fácilmente y, por ello, son excelentes para ambientes con gran afluencia de público.

D Elegante und funktionale kollektive Sitzlösungen, die zu verschiedenen Räumlichkeiten, von kleinen bis zu großen Warteräumen, passen. Die verwendeten Materialien können leicht gesäubert und hygienisiert werden, sind also besonders geeignet für Räume, wo sich viele Menschen aufhalten.

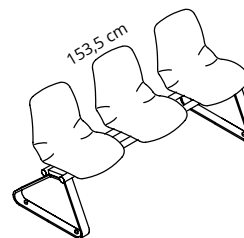
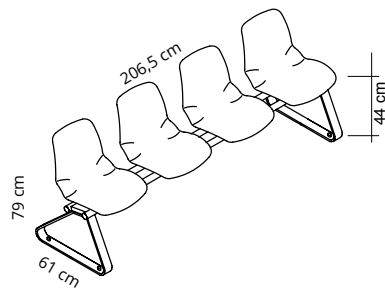

CD.	9K904-GR	9K903-GR
PR.	€ 1.030,00	€ 970,00
CL.	GR	GR

DS. Seduta in tecnopolimero e struttura in acciaio verniciato grigio argento.
 High-tech polymer seat and silver grey powder-coated steel frame.
 Assise en technopolymère et structure en acier peint gris argenté.
 Asiento en tecnopolimero y estructura en acero barnizado gris plata.
 Sitzschale aus Technopolymer und Gestell aus beschichtetem Stahl, silbergrau.



GR
 Grigio
 Grey
 Gris
 Grau

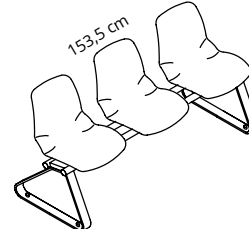
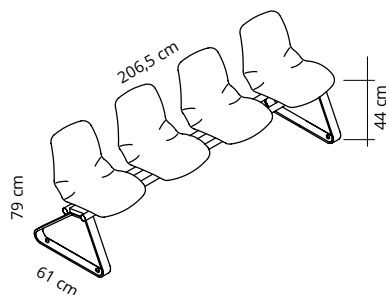

CD.	9K904-BO	9K903-BO
PR.	€ 1.190,00	€ 1.090,00
CL.	BO	BO

DS. Seduta in tecnopolimero e struttura in acciaio verniciato grigio argento.
 High-tech polymer seat and silver grey powder-coated steel frame.
 Assise en technopolymère et structure en acier peint gris argenté.
 Asiento en tecnopolimero y estructura en acero barnizado gris plata.
 Sitzschale aus Technopolymer und Gestell aus beschichtetem Stahl, silbergrau.



BO
 Bianco opaco
 Mat white
 Blanc mat
 Blanco mate
 Mattweiß

N
Nero
Black
Noir
Negro
Schwarz

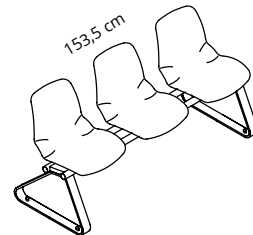
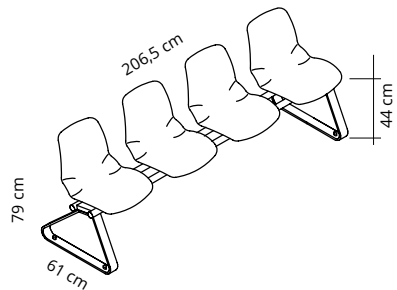

CD.	9K904-N	9K903-N
PR.	€ 1.190,00	€ 1.090,00
CL.	N	N

DS. Seduta in tecnopolimero e struttura in acciaio verniciato grigio argento.
High-tech polymer seat and silver grey powder-coated steel frame.
Assise en technopolymère et structure en acier peint gris argenté.
Asiento en tecnopolimero y estructura en acero barnizado gris plata.
Sitzschale aus Technopolymer und Gestell aus beschichtetem Stahl, silbergrau.

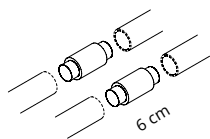

CD.	9K96-GA
PR.	€ 55,00
CL.	GA

DS. Coppia di giunti in acciaio verniciato per collegamento lineare delle travi.
Pair of powder-coated steel joints for beams linear connection.
Paire de joints en acier peint pour la connexion linéaire des poutres.
Par de juntas de acero barnizado para conexión lineal de vigas.
Paar pulverbeschichtete Stahlgelenke für die lineare Verbindung von Trägern.



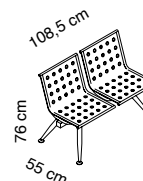
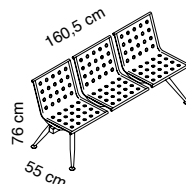
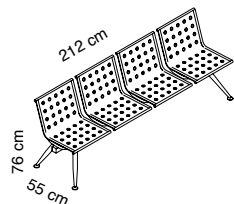
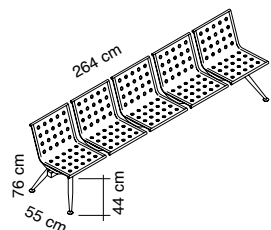

GQM
Grigio quarzo metallizzato.
Metal quartz grey.
Gris quartz metallisé.
Gris cuarzo metalizado.
Grau quarz metallic.



CD.	9657-GQM	9647-GQM	9637-GQM	9627-GQM
PR.	€ 1.458,00	€ 1.245,00	€ 1.032,00	€ 819,00
CL.	GQM	GQM	GQM	GQM

DS. Strutture e sedute in acciaio verniciato grigio quarzo metallizzato.
Metal quartz grey powder-coated steel frames and seats.
Structures et assises en acier peint gris quartz métallisé.
Estructuras y asientos en acero barnizado gris cuarzo metalizado.
Struktur und Sitze aus grau quarz metallic pulverbeschichtetem Stahl.

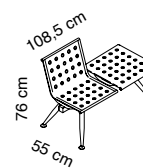
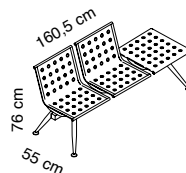
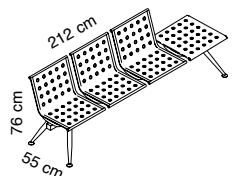
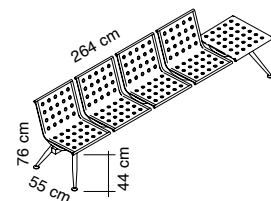

GQM
Grigio quarzo metallizzato.
Metal quartz grey.
Gris quartz metallisé.
Gris cuarzo metalizado.
Grau quarz metallic.



CD.	9658-GQM	9648-GQM	9638-GQM	9628-GQM
PR.	€ 1.448,00	€ 1.235,00	€ 1.022,00	€ 809,00
CL.	GQM	GQM	GQM	GQM

DS. Strutture, sedute e tavolini in acciaio verniciato grigio quarzo metallizzato. **Il tavolino può essere montato nella posizione desiderata.**
Metal quartz grey powder-coated steel frames, seats and small tables. **The table can be fixed in the desired position.**
Structures, assises et tabourets en acier peint gris quartz métallisé. **Le tabouret peut être fixé où on veut.**
Estructuras y mesas en acero barnizado gris cuarzo metalizado. **La mesa se puede montar en la posición deseada.**
Struktur, Sitze und Tischchen aus grau quarz metallic pulverbeschichtetem Stahl. **Das Tischchen kann in jeder Position befestigt werden.**

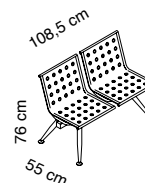
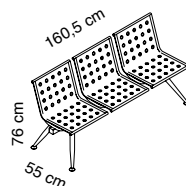
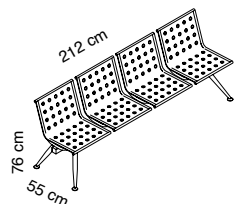
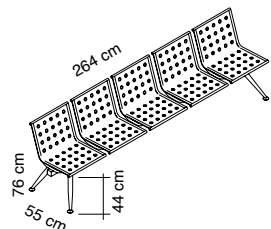

NM
Nero micaceo.
Micaceous black.
Noir micacé.
Negro micáceo.
Schwarz glimmerhaltig.

CD.	9657-NM	9647-NM	9637-NM	9627-NM
PR.	€ 1.458,00	€ 1.245,00	€ 1.032,00	€ 819,00
CL.	NM	NM	NM	NM

DS. Strutture in acciaio verniciato grigio quarzo metallizzato e sedute in acciaio verniciato nero micaceo.
Metal quartz grey powder-coated steel frames and micaceous black powder-coated steel seats.
Structures en acier peint gris quartz métallisé et assises en acier peint noir micacé.
Estructuras en acero barnizado gris cuarzo metalizado y asientos en acero barnizado negro micáceo.
Struktur aus grau quarz metallic pulverbeschichtetem Stahl und Sitze aus schimmernd-schwarz pulverbeschichtetem Stahl.

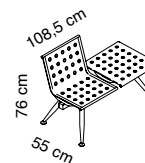
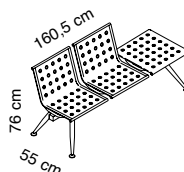
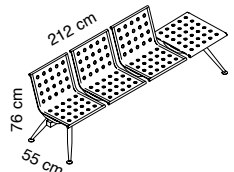
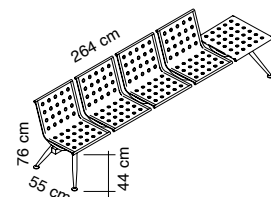

NM
Nero micaceo.
Micaceous black.
Noir micacé.
Negro micáceo.
Schwarz glimmerhaltig.

CD.	9658-NM	9648-NM	9638-NM	9628-NM
PR.	€ 1.448,00	€ 1.235,00	€ 1.022,00	€ 809,00
CL.	NM	NM	NM	NM

DS. Strutture in acciaio verniciato grigio quarzo metallizzato, sedute e tavolini in acciaio verniciato nero micaceo. Il tavolino può essere montato nella posizione desiderata.
Metal quartz grey powder-coated steel frames, micaceous black powder-coated steel seats and small tables. The table can be fixed in the desired position.
Structures en acier peint gris quartz métallisé, assises et tabourets en acier peint noir micacé. Le tabouret peut être fixé où on veut.
Estructuras en acero barnizado gris cuarzo metalizado, asientos y mesas en acero barnizado negro micáceo. La mesa se puede montar en la posición deseada.
Struktur aus grau quarz metallic pulverbeschichtetem Stahl, Sitze und Tischchen aus schimmernd-schwarz pulverbeschichtetem Stahl. Das Tischchen kann in jeder Position befestigt werden.



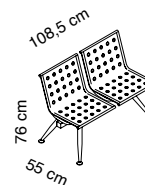
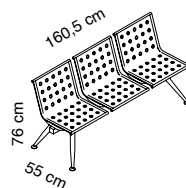
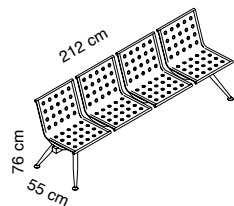
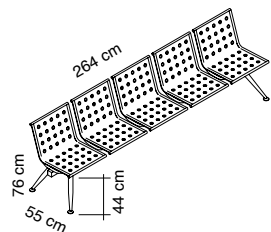

CD.	9657-AR	9647-AR	9637-AR	9627-AR
PR.	€ 1.458,00	€ 1.245,00	€ 1.032,00	€ 819,00
CL.	AR	AR	AR	AR

DS. Strutture in acciaio verniciato grigio quarzo metallizzato e sedute in acciaio verniciato arancione rosso.
 Metal quartz grey powder-coated steel frames and orange red powder-coated steel seats.
 Structures en acier peint gris quartz métallisé et assises en acier peint rouge orangé.
 Estructuras en acero barnizado gris cuarzo metalizado y asientos en acero barnizado rojo naranja.
 Struktur aus grau quarz metallic pulverbeschichtetem Stahl und Sitze aus orange-rot pulverbeschichtetem Stahl.

AR
 Arancione rosso
 Orange red
 Rouge orangé
 Rojo naranja
 Orange-rot

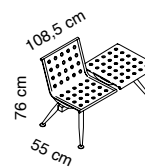
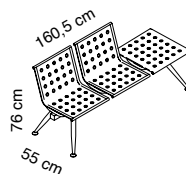
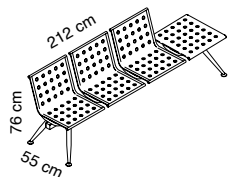
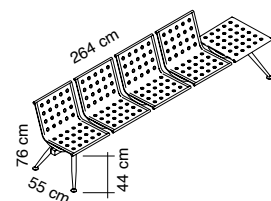
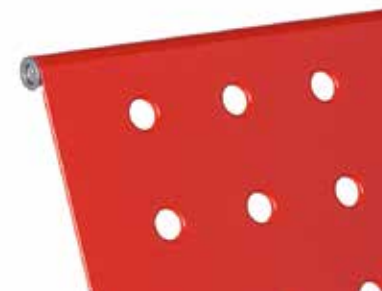







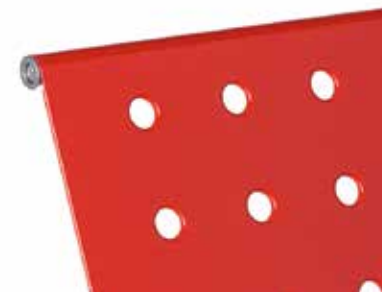

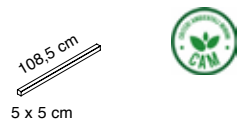
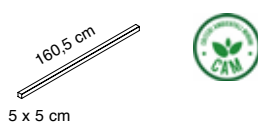
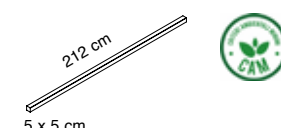
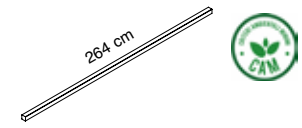
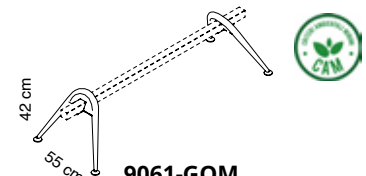





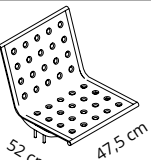



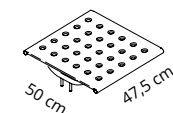

CD.	9658-AR	9648-AR	9638-AR	9628-AR
PR.	€ 1.448,00	€ 1.235,00	€ 1.022,00	€ 809,00
CL.	AR	AR	AR	AR

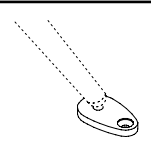
DS. Strutture in acciaio verniciato grigio quarzo metallizzato, sedute e tavolini in acciaio verniciato arancione rosso. Il tavolino può essere montato nella posizione desiderata.
 Metal quartz grey powder-coated steel frames, orange red powder-coated steel seats and small tables. The table can be fixed in the desired position.
 Structures en acier peint gris quartz métallisé, assises et tabourets en acier peint rouge orangé. Le tabouret peut être fixé où on veut.
 Estructuras en acero barnizado gris cuarzo metalizado, asientos y mesas en acero barnizado rojo naranja. La mesa se puede montar en la posición deseada.
 Struktur aus grau quarz metallic pulverbeschichtetem Stahl, Sitze und Tischchen aus orange-rot pulverbeschichtetem Stahl. Das Tischchen kann in jeder Position befestigt werden.

AR
 Arancione rosso
 Orange red
 Rouge orangé
 Rojo naranja
 Orange-rot

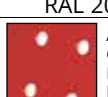

					
CD.	9069-GQM	9067-GQM	9065-GQM	9063-GQM	9061-GQM
PR.	€ 105,00	€ 110,00	€ 115,00	€ 120,00	€ 298,00
CL.	GQM	GQM	GQM	GQM	GQM
					
DS.	Trave 2 posti in acciaio verniciato. Powder-coated steel 2 places beam. Poutre 2 places en acier peint. Viga 2 plazas en acero barnizado. Traverse aus pulverbeschichtetem Stahl für 2 Sitze.	Trave 3 posti in acciaio verniciato. Powder-coated steel 3 places beam. Poutre 3 places en acier peint. Viga 3 plazas en acero barnizado. Traverse aus pulverbeschichtetem Stahl für 3 Sitze.	Trave 4 posti in acciaio verniciato. Powder-coated steel 4 places beam. Poutre 4 places en acier peint. Viga 4 plazas en acero barnizado. Traverse aus pulverbeschichtetem Stahl für 4 Sitze.	Trave 5 posti in acciaio verniciato. Powder-coated steel 5 places beam. Poutre 5 places en acier peint. Viga 5 plazas en acero barnizado. Traverse aus pulverbeschichtetem Stahl für 5 Sitze.	Coppia basi per travi in acciaio verniciato. Powder-coated steel pair of bases for beam. Paire de bases pour poutre en acier peint. Par de bases para viga en acero barnizado. Paar Standfüße aus pulverbeschichtetem Stahl für Traverse
	<p>Supporti verniciati grigio quarzo metallizzato. Powder-coated metal quartz grey supports. Supports peint gris quartz métallisé. Soportes barnizados gris cuarzo metalizado. Halterungen aus beschichtetem Stahl grau quarz metallic.</p>    				
CD.	9080-GQM	9080-NM	9080-AR		
PR.	€ 208,00	€ 208,00	€ 208,00		
CL.	GQM	NM	RAL 2002		
					
DS.	Seduta e supporti in acciaio verniciato. Powder-coated steel seat and supports. Assise et supports en acier peint. Asiento y soportes en acero barnizado. Sitzschale und Halterungen aus pulverbeschichtetem Stahl.				
	<p>Supporti verniciati grigio quarzo metallizzato. Powder-coated metal quartz grey supports. Supports peint gris quartz métallisé. Soportes barnizados gris cuarzo metalizado. Halterungen aus beschichtetem Stahl grau quarz metallic.</p>  			 	
CD.	9090-GQM	9090-NM	9090-AR	9075-GM	
PR.	€ 198,00	€ 198,00	€ 198,00	€ 59,00	
CL.	GQM	NM	RAL 2002	GM	
					
DS.	Tavolino e supporti in acciaio verniciato. Powder-coated steel small table and supports. Tabouret et supports en acier peint. Mesa y soportes en acero barnizado. Tischchen und Halterungen aus pulverbeschichtetem Stahl.			Kit posizionamento a terra in acciaio verniciato per cod. 9061-GQM. Set of 4 floor fixings in powder-coated steel for code 9061-GQM. Set de 4 fixations au sol en acier peint pour réf. 9061-GQM. Set de 4 fijaciones al suelo en acero barnizado para code 9061-GQM. 4 Bodenhalterungen aus pulverbeschichtetem Stahl für Art. 9061-GQM.	

DIVIDERS

design

Caimi Lab

SI Design

I_Sistemi di schermi divisori, ideali per suddividere spazi in modo funzionale. Grazie alla loro modularità, possono essere configurati in base alle specifiche esigenze, permettendo una gestione flessibile degli ambienti. Questi elementi permettono di ottimizzare gli spazi, aumentando l'efficienza operativa degli edifici, attraverso soluzioni di design.

EN_These screen partition systems are ideal for functional room division. Their modularity ensures customisable configurations that can meet specific needs as part of flexible space management. These elements are ideal for the optimal use of spaces, improving the operational efficiency of buildings through thoughtful design solutions.

F_Des systèmes de cloisons idéaux pour subdiviser les espaces de manière fonctionnelle. Grâce à leur modularité, ils peuvent être configurés en fonction de besoins spécifiques, ce qui permet une gestion flexible des espaces. Ces éléments permettent d'optimiser les espaces, en augmentant l'efficacité opérationnelle des immeubles, grâce à des solutions de design.

E_Sistemas de mamparas divisorias idóneas para subdividir los espacios de manera funcional. Gracias a su modularidad, pueden configurarse en función de las necesidades específicas, facilitando una gestión flexible de los espacios. Dichos elementos permiten optimizar el ambiente, incrementando así la eficacia operativa de los edificios mediante soluciones de diseño.

D_Trennwandsysteme, ideal für eine funktionelle Raumaufteilung. Dank ihrer Modularität können sie als Bestandteil eines flexiblen Space Management nach Kundenbedarf zusammengestellt werden. Diese Elemente sind ideal für optimale Raumnutzung, indem sie die operative Effizienz von Gebäuden durch eine planerisch durchdachte Anordnung verbessern.

La flessibilità dei pannelli Arianna permette di ottenere configurazioni dritte o curve semplicemente avvicinando o allontanando i montanti.

The suppleness of Arianna panels allows to obtain straight or curved compositions, simply by moving the uprights closer or away.

La souplesse des panneaux Arianna permet d'obtenir des compositions droites ou courbes par simple déplacement des montants.

La flexibilidad de los paneles Arianna permite configuraciones rectas o curvas simplemente acercando/alejando los laterales.

Durch die Flexibilität der Arianna-Paneele können diese gerade oder gebogen aufgestellt werden, indem die Distanz zwischen den Stehern verändert wird.

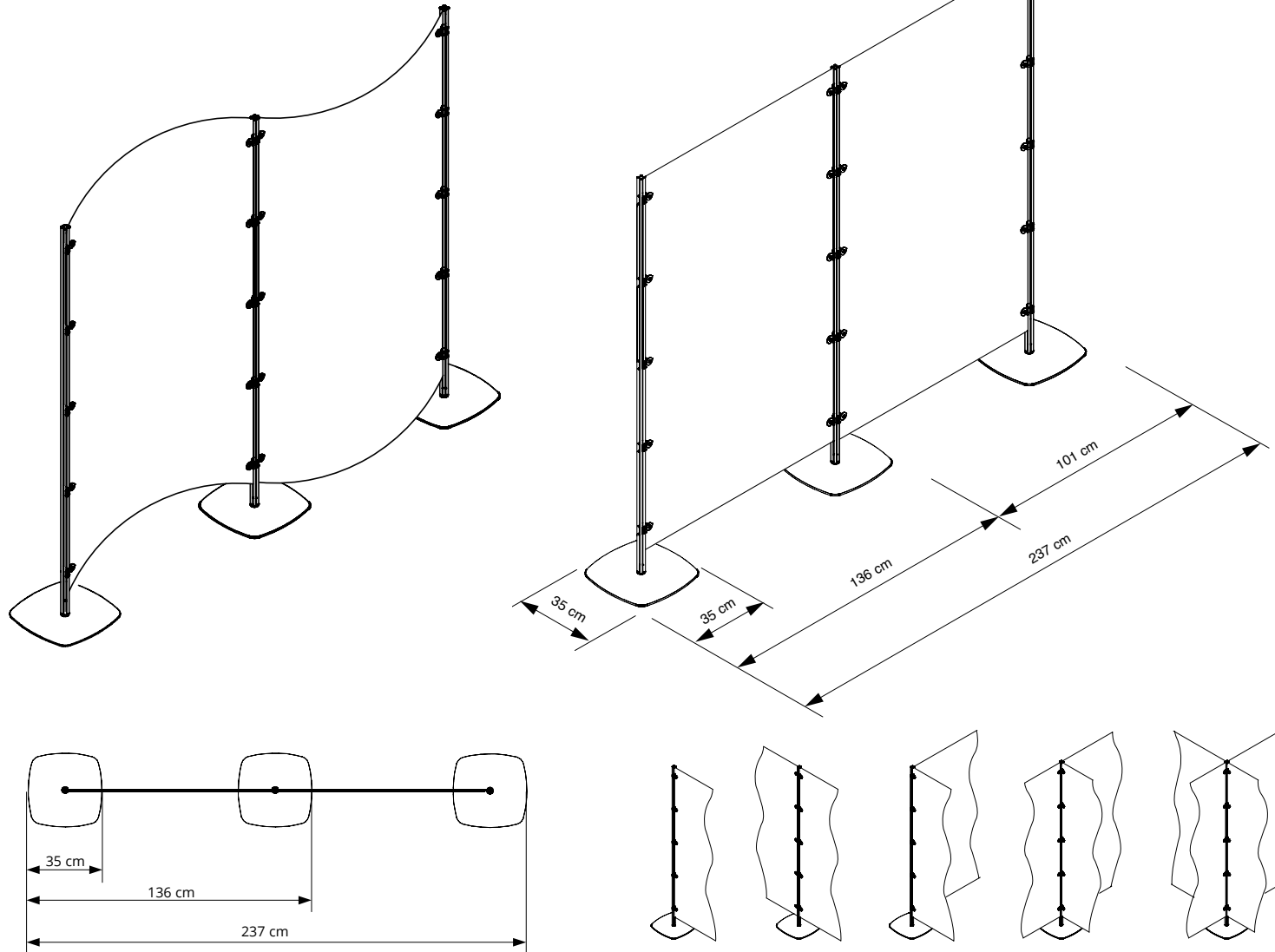

I pannelli cod. 6312 possono facilmente essere personalizzati tramite stampa serigrafica o stampa digitale.

Poiché il pannello è semi-trasparente, la stampa è possibile su un solo lato.

The panels codes 6312 can be easily customized through screen printing or digital printing. Since the panels are semitransparent, the printing is possible on one side only.

Les panneaux réf. 6312 sont facilement personnalisables grâce à l'impression sérigraphie ou numérique. Vu que le panneau est semi-transparent, l'impression n'est possible que d'un seul côté.

Los paneles cod. 6312 se pueden fácilmente personalizar mediante impresión serigráfica o impresión digital. Desde el panel es semitransparente, la impresión sólo puede realizarse por un lado.

Die Paneele Art. 6312 sind leicht durch Siebdruck oder Digitaldruck individuell zu gestalten. Da das Paneel halbdurchsichtig ist, kann nur eine Seite bedruckt werden.

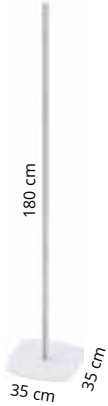
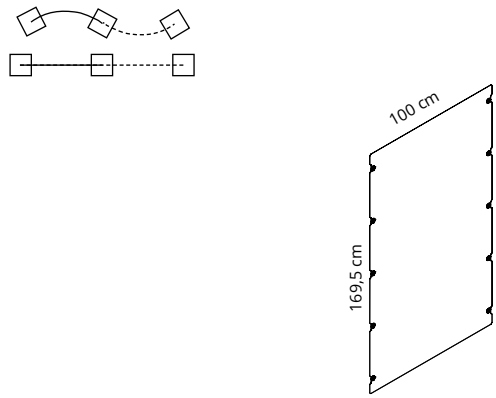

 <p>6018-BO € 198,00</p>	 <p>6312 € 278,00</p>
<p>CD.</p>	<p>CD.</p>
<p>PR.</p>	<p>PR.</p>
<p>CL.</p>	<p>CL.</p>
<p>DS.</p> <p>Montanti in tondino d'acciaio verniciato con polveri epossidiche con tappo superiore in tecnopolimero traslucido. Completi di base. Uprights in powder-coated steel rod, upper cap in translucent high-tech polymer. With base. Montant en rond d'acier peint époxy, protection supérieure en technopolymère translucide. Avec base. Laterales en redondo de acero pintado con polvo epoxi con tapón superior en tecnopolimero traslucido. Con base. Standsäule aus mit Epoxypulver beschichtetem Stahl, mit Abdeckkappe aus durchscheinendem Technopolymer. Mit Bodenplatte.</p>	<p>Pannelli in policarbonato bianco traslucido satinato su entrambi i lati, completi di attacchi fissi. Panels in translucent white polycarbonate satinized on both sides, fixed connectors included. Panneaux réalisés en polycarbonate blanc translucide satiné sur les deux côtés, joints fixes inclus. Paneles realizados en policarbonato blanco traslucido satinado en ambos lados, juntas fijas incluidas. Paneele aus lichtdurchlässigem, weißem, beidseitig satiniertem Polykarbonat, Feste Verbindungsstücke inbegriffen.</p>



BO
Bianco opaco.
Mat white.
Blanc opaque.
Blanco mate.
Mattweiss.



Modulo base
Start unit
cod.ARI37-BO
€ 674,00
composto da:
2x 6018-BO
1x 6312



Modulo seguito
Add-on unit
cod.ARI38-BO
€ 476,00
composto da:
1x 6018-BO
1x 6312



SOUND ABSORBING PANELS

MODULO BASE STARTING MODULE

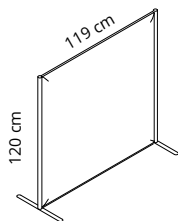

MODULO SEGUITO ADD-ON MODULE

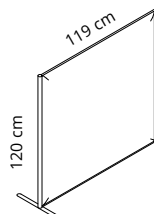

MODULO BASE STARTING MODULE

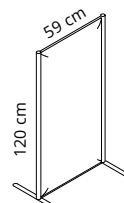

MODULO SEGUITO ADD-ON MODULE

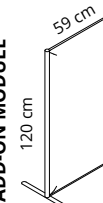

Colore Colour	Codice/Code Prezzo/Price	Codice/Code Prezzo/Price	Codice/Code Prezzo/Price	Codice/Code Prezzo/Price
Bianco White	0001 6CL1P-0001 € 860,00	6CL1PS-0001 € 760,00	6CL2P-0001 € 569,00	6CL2PS-0001 € 469,00
Bianco ghiaccio Cool white	8002 6CL1P-8002 € 860,00	6CL1PS-8002 € 760,00	6CL2P-8002 € 569,00	6CL2PS-8002 € 469,00
Grigio argento Silver grey	8004 6CL1P-8004 € 860,00	6CL1PS-8004 € 760,00	6CL2P-8004 € 569,00	6CL2PS-8004 € 469,00
Grigio scuro Dark grey	8007 6CL1P-8007 € 860,00	6CL1PS-8007 € 760,00	6CL2P-8007 € 569,00	6CL2PS-8007 € 469,00
Beige Beige	1008 6CL1P-1008 € 860,00	6CL1PS-1008 € 760,00	6CL2P-1008 € 569,00	6CL2PS-1008 € 469,00
Giallo Yellow	3008 6CL1P-3008 € 860,00	6CL1PS-3008 € 760,00	6CL2P-3008 € 569,00	6CL2PS-3008 € 469,00
Arancione Orange	4030 6CL1P-4030 € 860,00	6CL1PS-4030 € 760,00	6CL2P-4030 € 569,00	6CL2PS-4030 € 469,00
Rosso Red	4027 6CL1P-4027 € 860,00	6CL1PS-4027 € 760,00	6CL2P-4027 € 569,00	6CL2PS-4027 € 469,00
Verde chiaro Light green	7004 6CL1P-7004 € 860,00	6CL1PS-7004 € 760,00	6CL2P-7004 € 569,00	6CL2PS-7004 € 469,00
Azzurro Light blue	6046 6CL1P-6046 € 860,00	6CL1PS-6046 € 760,00	6CL2P-6046 € 569,00	6CL2PS-6046 € 469,00
Ottanio Teal	6075 6CL1P-6075 € 860,00	6CL1PS-6075 € 760,00	6CL2P-6075 € 569,00	6CL2PS-6075 € 469,00
Nero Black	8033 6CL1P-8033 € 860,00	6CL1PS-8033 € 760,00	6CL2P-8033 € 569,00	6CL2PS-8033 € 469,00

Paretina divisoria con montanti in alluminio verniciato e pannello con imbottitura interna in poliester a densità variabile Snowsound Technology. Rivestimento esterno in tessuto di poliester Trevira CS. Basi piatte in acciaio verniciato.

Partition with epoxy coated aluminium uprights and panel with Snowsound Technology variable-density polyester interior padding. External covering in Trevira CS polyester fabric. Epoxy coated steel flat bases.

Cloison avec montants en aluminium peint époxy et panneau avec rembourrage intérieur en polyester à densité variable Snowsound Technology. Revêtement extérieur en tissu polyester Trevira CS. Bases plates en acier peint époxy.

Tabique con montantes de aluminio barnizado y panel con acolchado interior de poliéster de densidad variable Snowsound Technology. Revestimiento exterior en tejido de poliéster Trevira CS. Bases planas de acero barnizado.

Trennwand mit lackierten Aluminiumpfosten und Paneel mit Snowsound Technology-Polsterung mit variabler Dichte. Außenverkleidung aus Polyestergewebe Trevira CS. Flache Sockel aus beschichtetem Stahl.

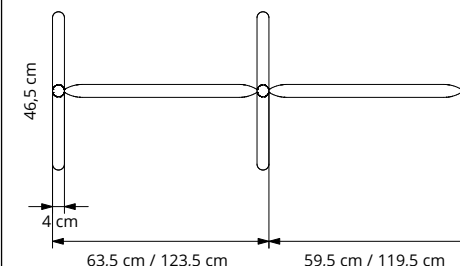



SOUND ABSORBING PANELS

MODULO BASE
STARTING MODULE

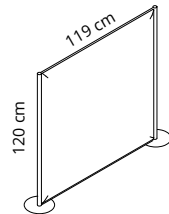

MODULO SEGUITO
ADD-ON MODULE

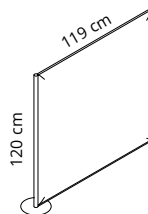

MODULO BASE
STARTING MODULE

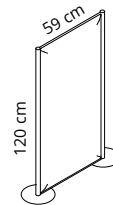

MODULO SEGUITO
ADD-ON MODULE

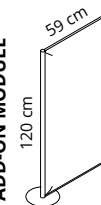

Colore Colour	Codice/Code Prezzo/Price	Codice/Code Prezzo/Price	Codice/Code Prezzo/Price	Codice/Code Prezzo/Price
Bianco White	0001 6CL1R-0001 € 920,00	6CL1RS-0001 € 820,00	6CL2R-0001 € 609,00	6CL2RS-0001 € 509,00
Bianco ghiaccio Cool white	8002 6CL1R-8002 € 920,00	6CL1RS-8002 € 820,00	6CL2R-8002 € 609,00	6CL2RS-8002 € 509,00
Grigio argento Silver grey	8004 6CL1R-8004 € 920,00	6CL1RS-8004 € 820,00	6CL2R-8004 € 609,00	6CL2RS-8004 € 509,00
Grigio scuro Dark grey	8007 6CL1R-8007 € 920,00	6CL1RS-8007 € 820,00	6CL2R-8007 € 609,00	6CL2RS-8007 € 509,00
Beige Beige	1008 6CL1R-1008 € 920,00	6CL1RS-1008 € 820,00	6CL2R-1008 € 609,00	6CL2RS-1008 € 509,00
Giallo Yellow	3008 6CL1R-3008 € 920,00	6CL1RS-3008 € 820,00	6CL2R-3008 € 609,00	6CL2RS-3008 € 509,00
Arancione Orange	4030 6CL1R-4030 € 920,00	6CL1RS-4030 € 820,00	6CL2R-4030 € 609,00	6CL2RS-4030 € 509,00
Rosso Red	4027 6CL1R-4027 € 920,00	6CL1RS-4027 € 820,00	6CL2R-4027 € 609,00	6CL2RS-4027 € 509,00
Verde chiaro Light green	7004 6CL1R-7004 € 920,00	6CL1RS-7004 € 820,00	6CL2R-7004 € 609,00	6CL2RS-7004 € 509,00
Azzurro Light blue	6046 6CL1R-6046 € 920,00	6CL1RS-6046 € 820,00	6CL2R-6046 € 609,00	6CL2RS-6046 € 509,00
Ottanio Teal	6075 6CL1R-6075 € 920,00	6CL1RS-6075 € 820,00	6CL2R-6075 € 609,00	6CL2RS-6075 € 509,00
Nero Black	8033 6CL1R-8033 € 920,00	6CL1RS-8033 € 820,00	6CL2R-8033 € 609,00	6CL2RS-8033 € 509,00

Paretina divisoria con montanti in alluminio verniciato e pannello con imbottitura interna in poliester a densità variabile Snowsound Technology. Rivestimento esterno in tessuto di poliester Trevira CS. Basi tonde in acciaio verniciato.

Partition with epoxy coated aluminium uprights and panel with Snowsound Technology variable-density polyester interior padding. External covering in Trevira CS polyester fabric. Epoxy coated steel round bases.

Cloison avec montants en aluminium peint époxy et panneau avec rembourrage intérieur en polyester à densité variable Snowsound Technology. Revêtement extérieur en tissu polyester Trevira CS. Bases rondes en acier peint époxy.

Tabique con montantes de aluminio barnizado y panel con acolchado interior de poliéster de densidad variable Snowsound Technology. Revestimiento exterior en tejido de poliéster Trevira CS. Bases redondas de acero barnizado.

Trennwand mit lackierten Aluminiumpfosten und Paneel mit Snowsound Technology-Polsterung mit variabler Dichte. Außenverkleidung aus Polyestergewebe Trevira CS. Runde Sockel aus beschichtetem Stahl.

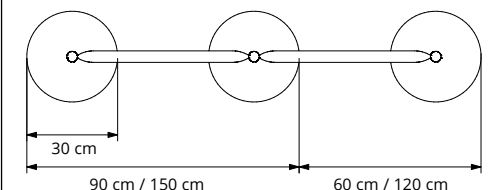

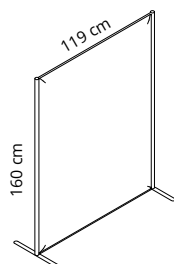
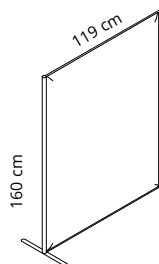
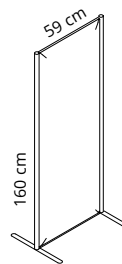
**SOUND ABSORBING PANELS**
**MODULO BASE
STARTING MODULE**

**MODULO SEGUITO
ADD-ON MODULE**

**MODULO BASE
STARTING MODULE**

**MODULO SEGUITO
ADD-ON MODULE**

Colore Colour	Codice/Code Prezzo/Price	Codice/Code Prezzo/Price	Codice/Code Prezzo/Price	Codice/Code Prezzo/Price
Bianco White	0001 6CL3P-0001 € 980,00	6CL3PS-0001 € 880,00	6CL4P-0001 € 633,00	6CL4PS-0001 € 533,00
Bianco ghiaccio Cool white	8002 6CL3P-8002 € 980,00	6CL3PS-8002 € 880,00	6CL4P-8002 € 633,00	6CL4PS-8002 € 533,00
Grigio argento Silver grey	8004 6CL3P-8004 € 980,00	6CL3PS-8004 € 880,00	6CL4P-8004 € 633,00	6CL4PS-8004 € 533,00
Grigio scuro Dark grey	8007 6CL3P-8007 € 980,00	6CL3PS-8007 € 880,00	6CL4P-8007 € 633,00	6CL4PS-8007 € 533,00
Beige Beige	1008 6CL3P-1008 € 980,00	6CL3PS-1008 € 880,00	6CL4P-1008 € 633,00	6CL4PS-1008 € 533,00
Giallo Yellow	3008 6CL3P-3008 € 980,00	6CL3PS-3008 € 880,00	6CL4P-3008 € 633,00	6CL4PS-3008 € 533,00
Arancione Orange	4030 6CL3P-4030 € 980,00	6CL3PS-4030 € 880,00	6CL4P-4030 € 633,00	6CL4PS-4030 € 533,00
Rosso Red	4027 6CL3P-4027 € 980,00	6CL3PS-4027 € 880,00	6CL4P-4027 € 633,00	6CL4PS-4027 € 533,00
Verde chiaro Light green	7004 6CL3P-7004 € 980,00	6CL3PS-7004 € 880,00	6CL4P-7004 € 633,00	6CL4PS-7004 € 533,00
Azzurro Light blue	6046 6CL3P-6046 € 980,00	6CL3PS-6046 € 880,00	6CL4P-6046 € 633,00	6CL4PS-6046 € 533,00
Ottanio Teal	6075 6CL3P-6075 € 980,00	6CL3PS-6075 € 880,00	6CL4P-6075 € 633,00	6CL4PS-6075 € 533,00
Nero Black	8033 6CL3P-8033 € 980,00	6CL3PS-8033 € 880,00	6CL4P-8033 € 633,00	6CL4PS-8033 € 533,00

Paretina divisoria con montanti in alluminio verniciato e pannello con imbottitura interna in poliester a densità variabile Snowsound Technology. Rivestimento esterno in tessuto di poliester Trevira CS. Basi piatte in acciaio verniciato.

Partition with epoxy coated aluminium uprights and panel with Snowsound Technology variable-density polyester interior padding. External covering in Trevira CS polyester fabric. Epoxy coated steel flat bases.

Cloison avec montants en aluminium peint époxy et panneau avec rembourrage intérieur en polyester à densité variable Snowsound Technology. Revêtement extérieur en tissu polyester Trevira CS. Bases plates en acier peint époxy.

Tabique con montantes de aluminio barnizado y panel con acolchado interior de poliéster de densidad variable Snowsound Technology. Revestimiento exterior en tejido de poliéster Trevira CS. Bases planas de acero barnizado.

Trennwand mit lackierten Aluminiumpfosten und Paneel mit Snowsound Technology-Polsterung mit variabler Dichte. Außenverkleidung aus Polyestergewebe Trevira CS. Flache Sockel aus beschichtetem Stahl.

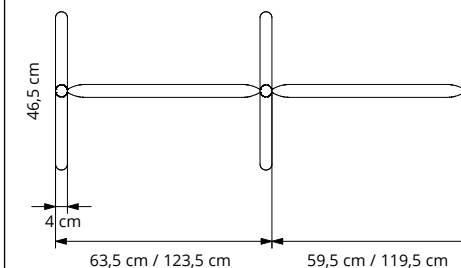



SOUND ABSORBING PANELS

MODULO BASE
STARTING MODULE

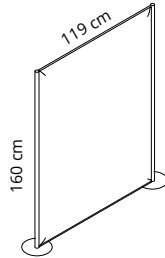

MODULO SEGUITO
ADD-ON MODULE

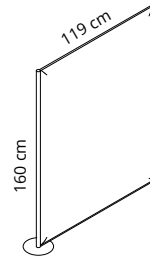

MODULO BASE
STARTING MODULE

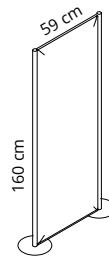

MODULO SEGUITO
ADD-ON MODULE

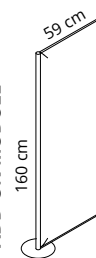

Colore Colour	Codice/Code Prezzo/Price	Codice/Code Prezzo/Price	Codice/Code Prezzo/Price	Codice/Code Prezzo/Price
Bianco White	0001 6CL3R-0001 € 1.050,00	6CL3RS-0001 € 950,00	6CL4R-0001 € 673,00	6CL4RS-0001 € 573,00
Bianco ghiaccio Cool white	8002 6CL3R-8002 € 1.050,00	6CL3RS-8002 € 950,00	6CL4R-8002 € 673,00	6CL4RS-8002 € 573,00
Grigio argento Silver grey	8004 6CL3R-8004 € 1.050,00	6CL3RS-8004 € 950,00	6CL4R-8004 € 673,00	6CL4RS-8004 € 573,00
Grigio scuro Dark grey	8007 6CL3R-8007 € 1.050,00	6CL3RS-8007 € 950,00	6CL4R-8007 € 673,00	6CL4RS-8007 € 573,00
Beige Beige	1008 6CL3R-1008 € 1.050,00	6CL3RS-1008 € 950,00	6CL4R-1008 € 673,00	6CL4RS-1008 € 573,00
Giallo Yellow	3008 6CL3R-3008 € 1.050,00	6CL3RS-3008 € 950,00	6CL4R-3008 € 673,00	6CL4RS-3008 € 573,00
Arancione Orange	4030 6CL3R-4030 € 1.050,00	6CL3RS-4030 € 950,00	6CL4R-4030 € 673,00	6CL4RS-4030 € 573,00
Rosso Red	4027 6CL3R-4027 € 1.050,00	6CL3RS-4027 € 950,00	6CL4R-4027 € 673,00	6CL4RS-4027 € 573,00
Verde chiaro Light green	7004 6CL3R-7004 € 1.050,00	6CL3RS-7004 € 950,00	6CL4R-7004 € 673,00	6CL4RS-7004 € 573,00
Azzurro Light blue	6046 6CL3R-6046 € 1.050,00	6CL3RS-6046 € 950,00	6CL4R-6046 € 673,00	6CL4RS-6046 € 573,00
Ottanio Teal	6075 6CL3R-6075 € 1.050,00	6CL3RS-6075 € 950,00	6CL4R-6075 € 673,00	6CL4RS-6075 € 573,00
Nero Black	8033 6CL3R-8033 € 1.050,00	6CL3RS-8033 € 950,00	6CL4R-8033 € 673,00	6CL4RS-8033 € 573,00

Paretina divisoria con montanti in alluminio verniciato e pannello con imbottitura interna in poliester a densità variabile Snowsound Technology. Rivestimento esterno in tessuto di poliester Trevira CS. Basi tonde in acciaio verniciato.

Partition with epoxy coated aluminium uprights and panel with Snowsound Technology variable-density polyester interior padding. External covering in Trevira CS polyester fabric. Epoxy coated steel round bases.

Cloison avec montants en aluminium peint époxy et panneau avec rembourrage intérieur en polyester à densité variable Snowsound Technology. Revêtement extérieur en tissu polyester Trevira CS. Bases rondes en acier peint époxy.

Tabique con montantes de aluminio barnizado y panel con acolchado interior de poliéster de densidad variable Snowsound Technology. Revestimiento exterior en tejido de poliéster Trevira CS. Bases redondas de acero barnizado.

Trennwand mit lackierten Aluminiumpfosten und Paneel mit Snowsound Technology-Polsterung mit variabler Dichte. Außenverkleidung aus Polyestergewebe Trevira CS. Runde Sockel aus beschichtetem Stahl.

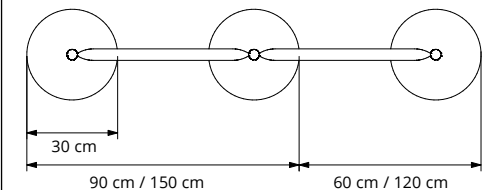

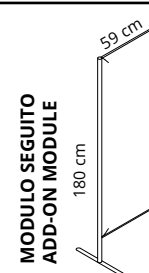
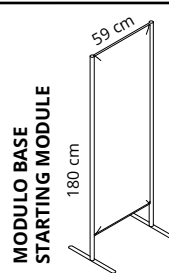
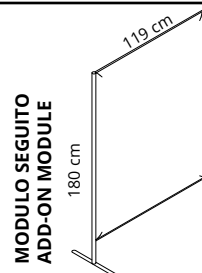
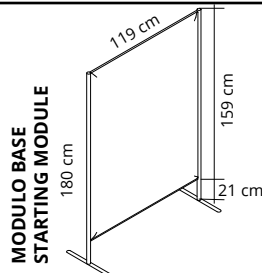
**SOUND ABSORBING
PANELS**

Colore Colour	Codice/Code Prezzo/Price	Codice/Code Prezzo/Price	Codice/Code Prezzo/Price	Codice/Code Prezzo/Price
Bianco White	0001 6CL5P-0001 € 990,00	6CL5PS-0001 € 890,00	6CL6P-0001 € 643,00	6CL6PS-0001 € 543,00
Bianco ghiaccio Cool white	8002 6CL5P-8002 € 990,00	6CL5PS-8002 € 890,00	6CL6P-8002 € 643,00	6CL6PS-8002 € 543,00
Grigio argento Silver grey	8004 6CL5P-8004 € 990,00	6CL5PS-8004 € 890,00	6CL6P-8004 € 643,00	6CL6PS-8004 € 543,00
Grigio scuro Dark grey	8007 6CL5P-8007 € 990,00	6CL5PS-8007 € 890,00	6CL6P-8007 € 643,00	6CL6PS-8007 € 543,00
Beige Beige	1008 6CL5P-1008 € 990,00	6CL5PS-1008 € 890,00	6CL6P-1008 € 643,00	6CL6PS-1008 € 543,00
Giallo Yellow	3008 6CL5P-3008 € 990,00	6CL5PS-3008 € 890,00	6CL6P-3008 € 643,00	6CL6PS-3008 € 543,00
Arancione Orange	4030 6CL5P-4030 € 990,00	6CL5PS-4030 € 890,00	6CL6P-4030 € 643,00	6CL6PS-4030 € 543,00
Rosso Red	4027 6CL5P-4027 € 990,00	6CL5PS-4027 € 890,00	6CL6P-4027 € 643,00	6CL6PS-4027 € 543,00
Verde chiaro Light green	7004 6CL5P-7004 € 990,00	6CL5PS-7004 € 890,00	6CL6P-7004 € 643,00	6CL6PS-7004 € 543,00
Azzurro Light blue	6046 6CL5P-6046 € 990,00	6CL5PS-6046 € 890,00	6CL6P-6046 € 643,00	6CL6PS-6046 € 543,00
Ottanio Teal	6075 6CL5P-6075 € 990,00	6CL5PS-6075 € 890,00	6CL6P-6075 € 643,00	6CL6PS-6075 € 543,00
Nero Black	8033 6CL5P-8033 € 990,00	6CL5PS-8033 € 890,00	6CL6P-8033 € 643,00	6CL6PS-8033 € 543,00

Paretina divisoria con montanti in alluminio verniciato e pannello con imbottitura interna in poliester a densità variabile Snowsound Technology. Rivestimento esterno in tessuto di poliester Trevira CS. Basi piatte in acciaio verniciato.

Partition with epoxy coated aluminium uprights and panel with Snowsound Technology variable-density polyester interior padding. External covering in Trevira CS polyester fabric. Epoxy coated steel flat bases.

Cloison avec montants en aluminium peint époxy et panneau avec rembourrage intérieur en polyester à densité variable Snowsound Technology. Revêtement extérieur en tissu polyester Trevira CS. Bases plates en acier peint époxy.

Tabique con montantes de aluminio barnizado y panel con acolchado interior de poliéster de densidad variable Snowsound Technology. Revestimiento exterior en tejido de poliéster Trevira CS. Bases planas de acero barnizado.

Trennwand mit lackierten Aluminiumpfosten und Paneel mit Snowsound Technology-Polsterung mit variabler Dichte. Außenverkleidung aus Polyestergewebe Trevira CS. Flache Sockel aus beschichtetem Stahl.

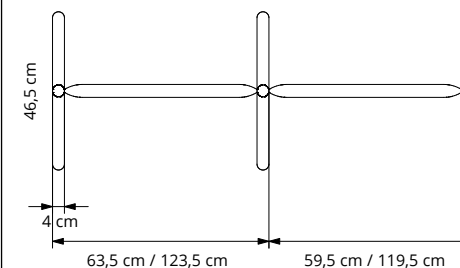



SOUND ABSORBING PANELS

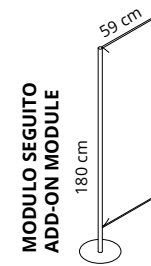
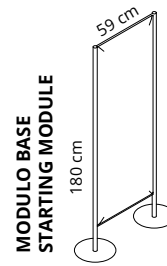
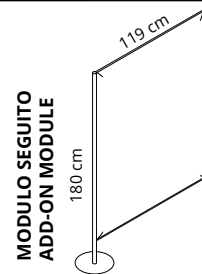
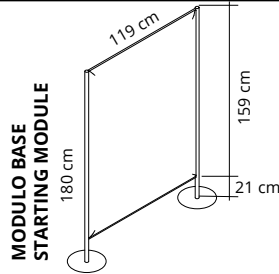

Colore Colour	Codice/Code Prezzo/Price	Codice/Code Prezzo/Price	Codice/Code Prezzo/Price	Codice/Code Prezzo/Price
Bianco White	0001 6CL5R-0001 € 1.060,00	6CL5RS-0001 € 960,00	6CL6R-0001 € 683,00	6CL6RS-0001 € 583,00
Bianco ghiaccio Cool white	8002 6CL5R-8002 € 1.060,00	6CL5RS-8002 € 960,00	6CL6R-8002 € 683,00	6CL6RS-8002 € 583,00
Grigio argento Silver grey	8004 6CL5R-8004 € 1.060,00	6CL5RS-8004 € 960,00	6CL6R-8004 € 683,00	6CL6RS-8004 € 583,00
Grigio scuro Dark grey	8007 6CL5R-8007 € 1.060,00	6CL5RS-8007 € 960,00	6CL6R-8007 € 683,00	6CL6RS-8007 € 583,00
Beige Beige	1008 6CL5R-1008 € 1.060,00	6CL5RS-1008 € 960,00	6CL6R-1008 € 683,00	6CL6RS-1008 € 583,00
Giallo Yellow	3008 6CL5R-3008 € 1.060,00	6CL5RS-3008 € 960,00	6CL6R-3008 € 683,00	6CL6RS-3008 € 583,00
Arancione Orange	4030 6CL5R-4030 € 1.060,00	6CL5RS-4030 € 960,00	6CL6R-4030 € 683,00	6CL6RS-4030 € 583,00
Rosso Red	4027 6CL5R-4027 € 1.060,00	6CL5RS-4027 € 960,00	6CL6R-4027 € 683,00	6CL6RS-4027 € 583,00
Verde chiaro Light green	7004 6CL5R-7004 € 1.060,00	6CL5RS-7004 € 960,00	6CL6R-7004 € 683,00	6CL6RS-7004 € 583,00
Azzurro Light blue	6046 6CL5R-6046 € 1.060,00	6CL5RS-6046 € 960,00	6CL6R-6046 € 683,00	6CL6RS-6046 € 583,00
Ottanio Teal	6075 6CL5R-6075 € 1.060,00	6CL5RS-6075 € 960,00	6CL6R-6075 € 683,00	6CL6RS-6075 € 583,00
Nero Black	8033 6CL5R-8033 € 1.060,00	6CL5RS-8033 € 960,00	6CL6R-8033 € 683,00	6CL6RS-8033 € 583,00

Paretina divisoria con montanti in alluminio verniciato e pannello con imbottitura interna in poliester a densità variabile Snowsound Technology. Rivestimento esterno in tessuto di poliester Trevira CS. Basi tonde in acciaio verniciato.

Partition with epoxy coated aluminium uprights and panel with Snowsound Technology variable-density polyester interior padding. External covering in Trevira CS polyester fabric. Epoxy coated steel round bases.

Cloison avec montants en aluminium peint époxy et panneau avec rembourrage intérieur en polyester à densité variable Snowsound Technology. Revêtement extérieur en tissu polyester Trevira CS. Bases rondes en acier peint époxy.

Tabique con montantes de aluminio barnizado y panel con acolchado interior de poliéster de densidad variable Snowsound Technology. Revestimiento exterior en tejido de poliéster Trevira CS. Bases redondas de acero barnizado.

Trennwand mit lackierten Aluminiumpfosten und Paneel mit Snowsound Technology-Polsterung mit variabler Dichte. Außenverkleidung aus Polyestergewebe Trevira CS. Runde Sockel aus beschichtetem Stahl.

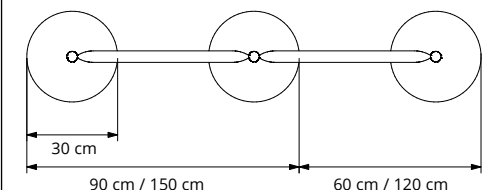

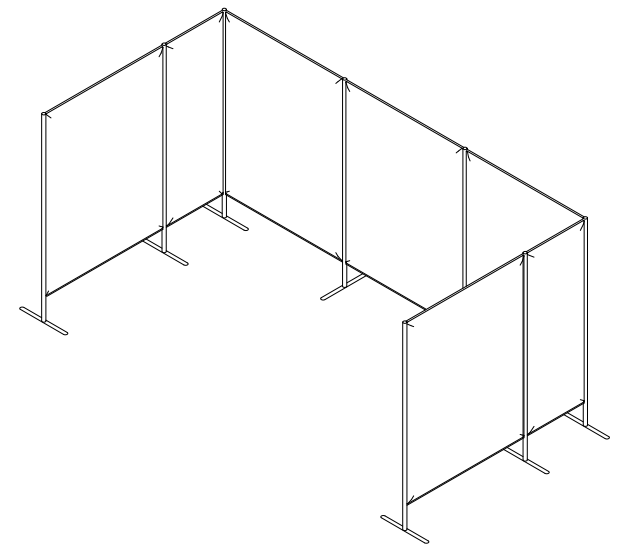
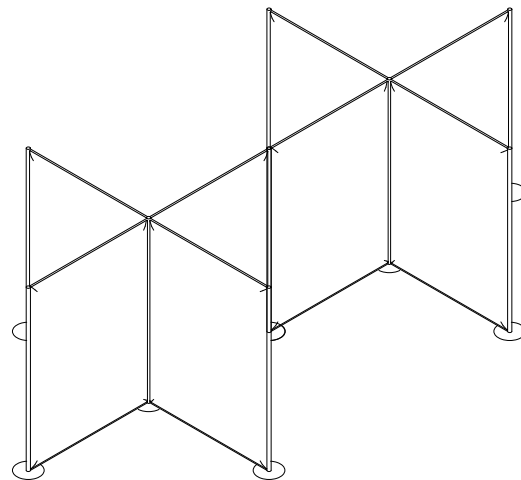
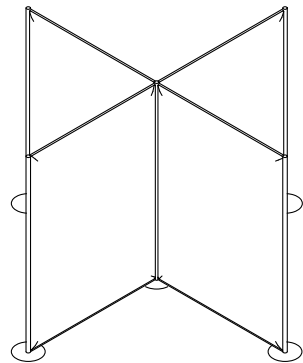
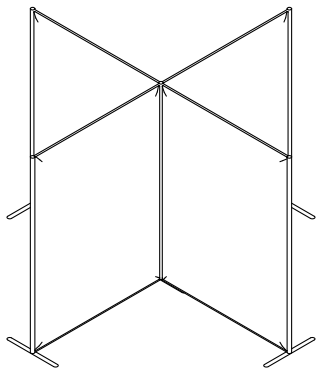

Snowsound Technology - Acoustic performance "A Class"

ANDAMENTO DEL COEFFICIENTE DI ASSORBIMENTO ACUSTICO "αs" PER TERZI D'OTTAVA
One-third octave sound absorption coefficient curve "αs"

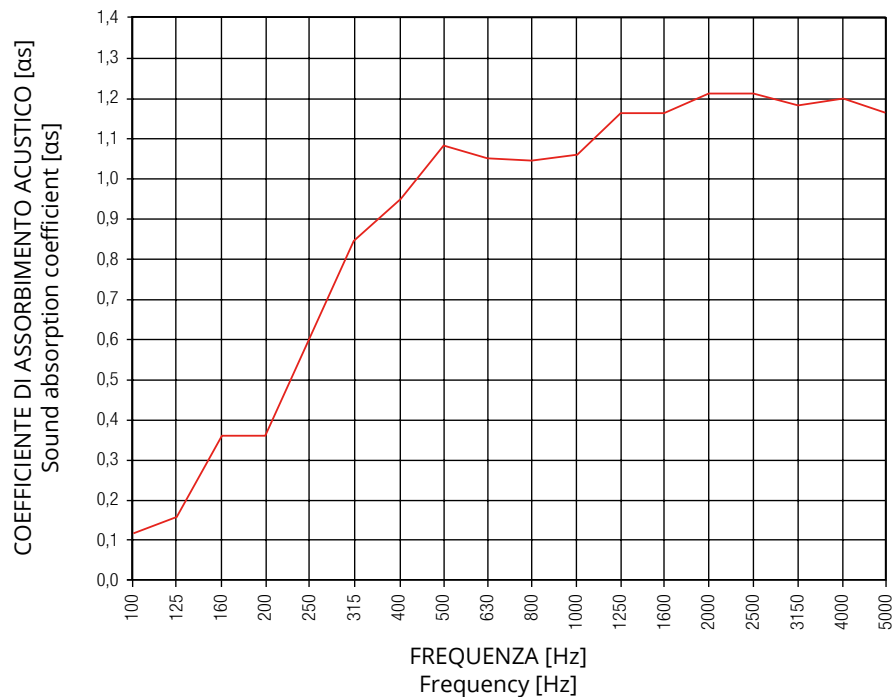

I_Misura dell'assorbimento acustico in camera riverberante UNI EN ISO 354 (pannelli Mitesco/Snowsound® installati accostati e con intercapedine d'aria posteriore di 200 mm).

EN_UNI EN ISO 354 measures sound-absorbing power in a reverberation room (Mitesco/Snowsound® panels installed side by side and with an 200 mm rear air space).

I_I pannelli Snowsound Technology sono stati testati in camera riverberante secondo la norma UNI EN ISO 354 ottenendo la "Classe di Assorbimento Acustico A" in accordo con la norma UNI EN ISO 11654.

EN_Snowsound Technology panels were tested in a reverberation room according to UNI EN ISO 354 standards obtaining "Class A sound absorption" to UNI EN ISO 11654 standards.

F_Les panneaux Snowsound Technology ont fait l'objet de tests en chambre réverbérante conformément à la norme UNI EN ISO 354, obtenant la "classe d'absorption acoustique A" selon la norme UNI EN ISO 11654.

E_Los paneles Snowsound Technology se probaron en cámara reverberante conformemente a la norma UNI EN ISO 354 consiguiendo la "Clase A de Absorción Acústica" en virtud de la norma UNI EN ISO 11654.

D_Die Snowsound Technology Paneele wurden gemäß der Norm UNI EN ISO 354 in einem Hallraum getestet. Sie erhielten gemäß der Norm UNI EN ISO 11654 die Klassifizierung "Schallabsorption A".



**Sound
absorbing
panel**



**Ascolta la
differenza
(video)**



**Listent to the
difference
(video)**

COMMUNICATION & MEETING

design

Sezgin Aksu

Angelotti & Cardile

Caimi Lab

Michele De Lucchi

I_Sistemi di segnaletica e comunicazione completi di espositori in diversi formati e accessori, caratterizzati da forme che li rendono adatti ad ogni tipo di ambiente. I sistemi di comunicazione sono versatili e riconfigurabili, appositamente studiati per sale polifunzionali, conferenze e riunioni.

EN_Signage and communication systems available in several different display formats and with accessories to suit any type of environment. The communication systems are versatile and reconfigurable, and have been specifically designed with multipurpose spaces, conference halls and meeting rooms in mind.

F_Systèmes de signalétique et de communication complets avec des présentoirs de différents formats et des accessoires, caractérisés par des formes qui les rendent adaptés à tout type de situation. Les systèmes de communication sont aptes à des usages multiples et reconfigurables, spécialement conçus pour les salles polyvalentes, les conférences et les réunions.

E_Sistemas de señalización y comunicación que cuentan con expositores de diferentes formatos y accesorios. Se caracterizan por un diseño que se ajusta a todo tipo de ambientes. Estos sistemas son versátiles y reconfigurables, ya que están concebidos específicamente para salas multifuncionales, de conferencias y de reuniones.

D_Beschildierungs- und Kommunikationssysteme mit Auslagen in verschiedenen Formaten und Zubehörelemente, die sich durch Formen auszeichnen, durch die sie sich für jeden Raum eignen. Die Systeme sind vielfach anwendbar und können umkonfiguriert werden. Sie sind eigens für Mehrzweck-Säle, Konferenz- und Versammlungsräume entworfen.

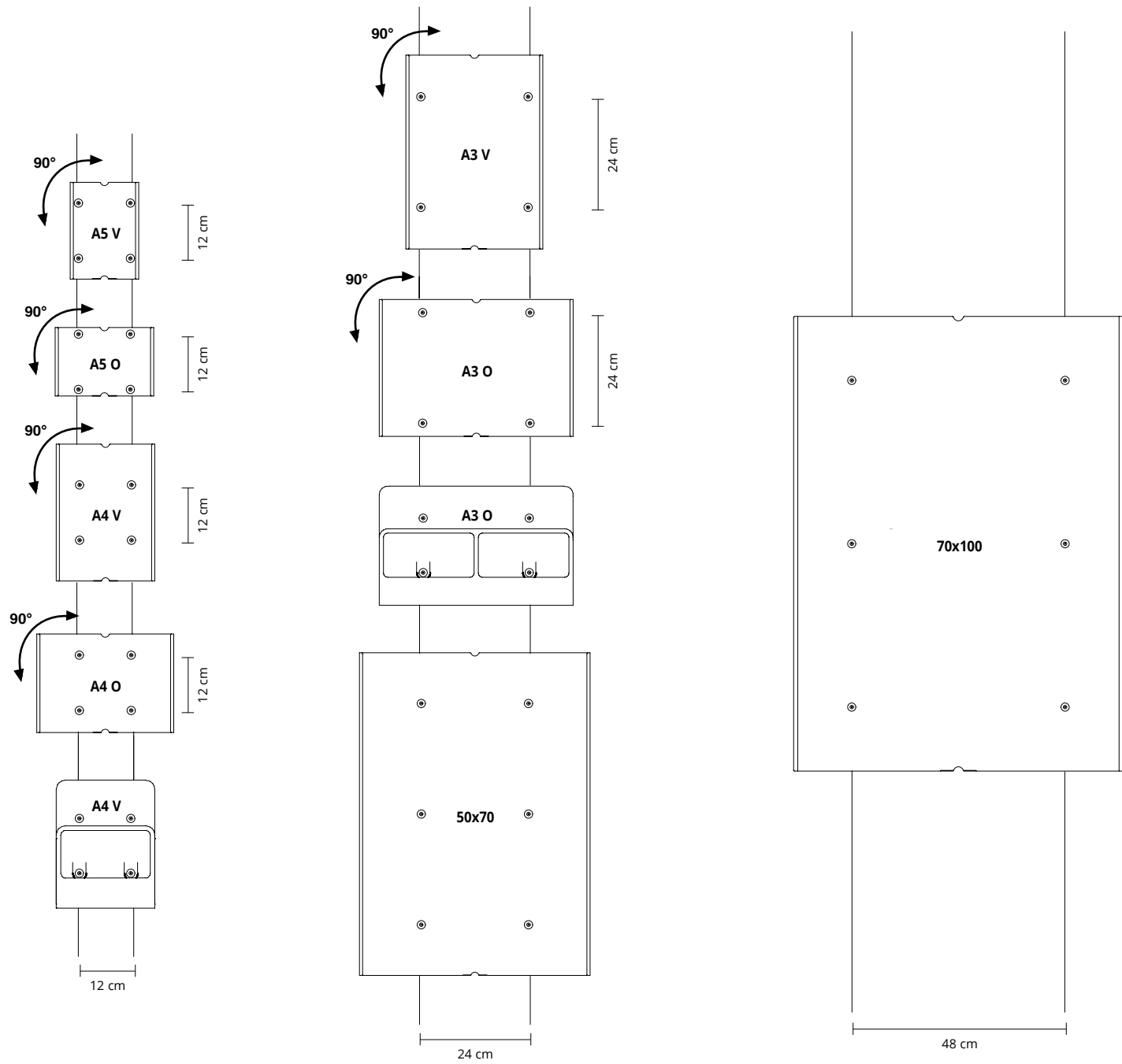

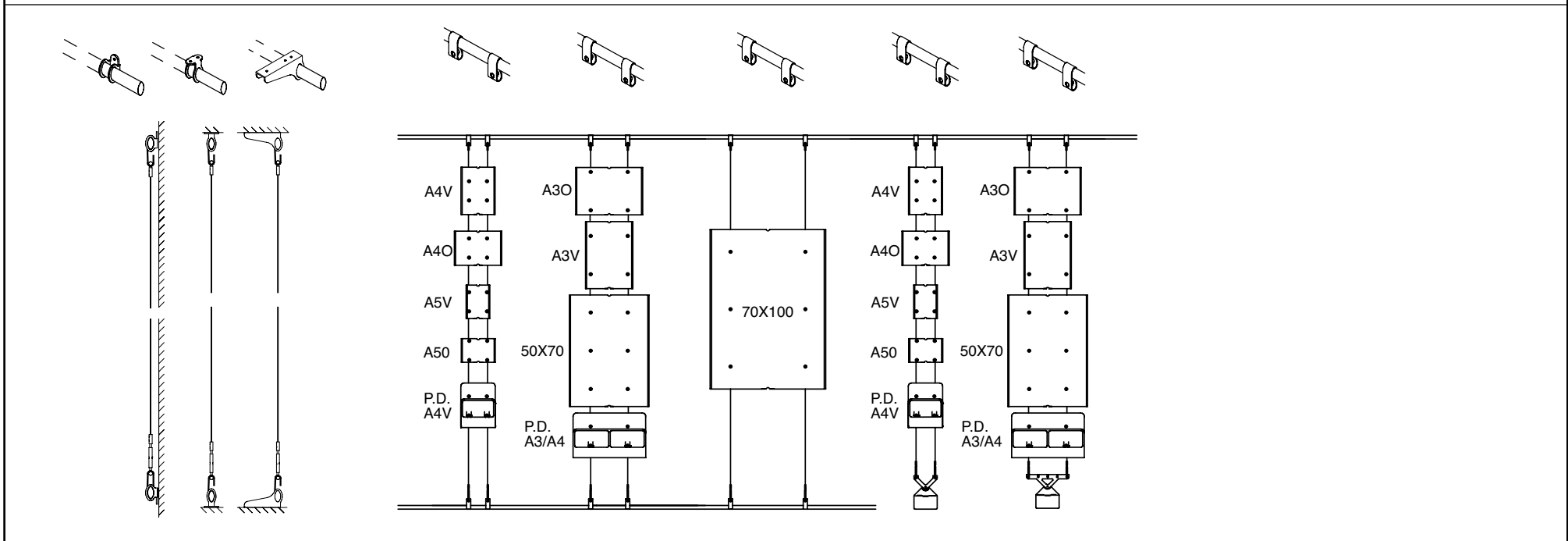
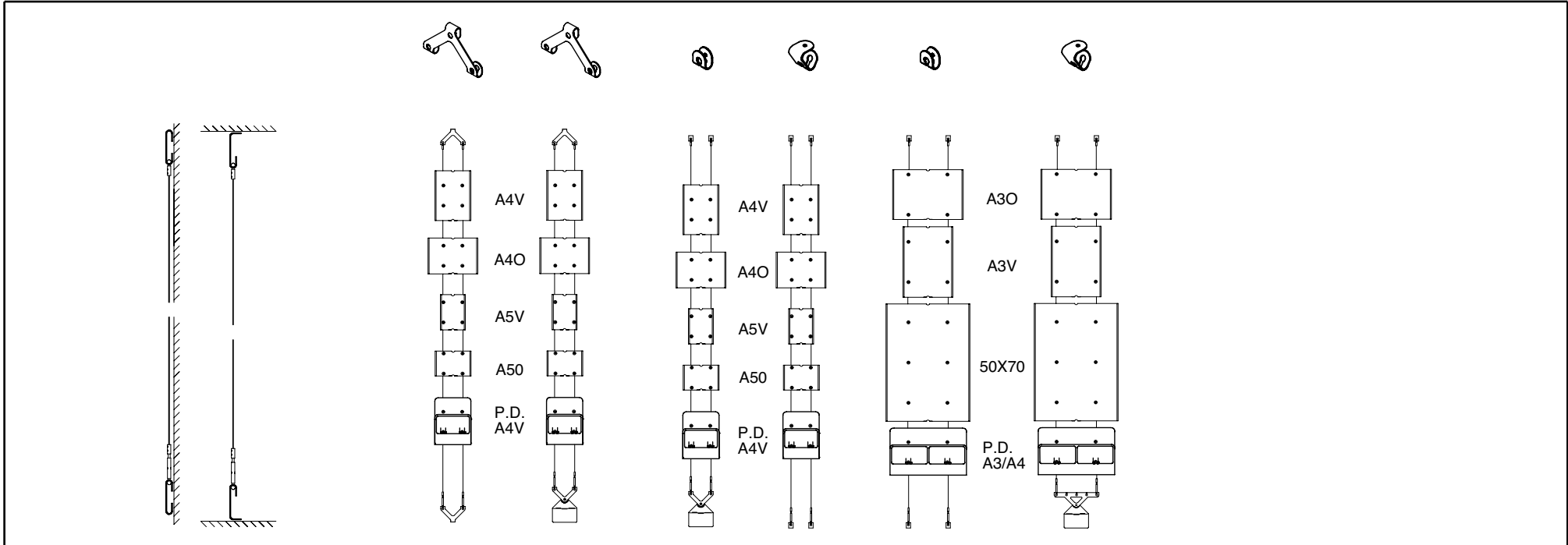

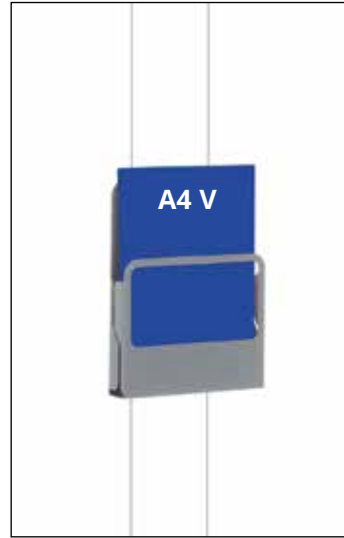
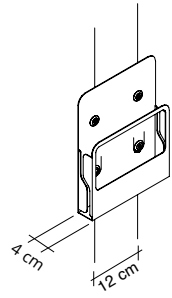
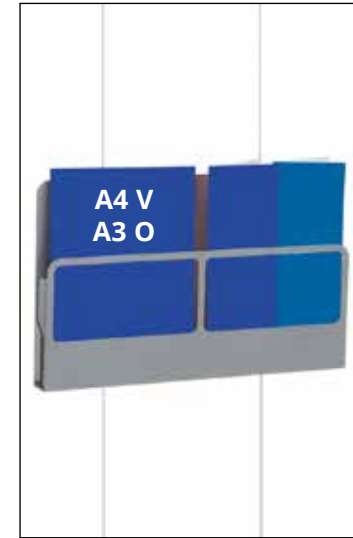
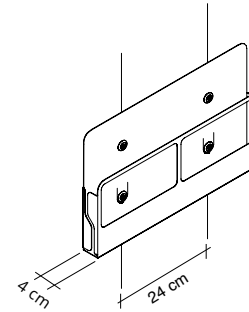
PORTADEPLIANT PER CAVI
LEAFLETS HOLDER FOR CABLES

PORTADEPLIANT PER CAVI
LEAFLETS HOLDER FOR CABLES

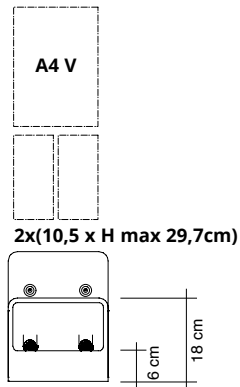
CD.	CL.	FORMATO	PR. €	L cm	H cm	Kg	CD.	CL.	FORMATO	PR. €	L cm	H cm	Kg
5195-GA	GA	A4 V	55,00	22	28	0,85	5196-GA	GA	A3 O	88,00	46,5	28	2,00

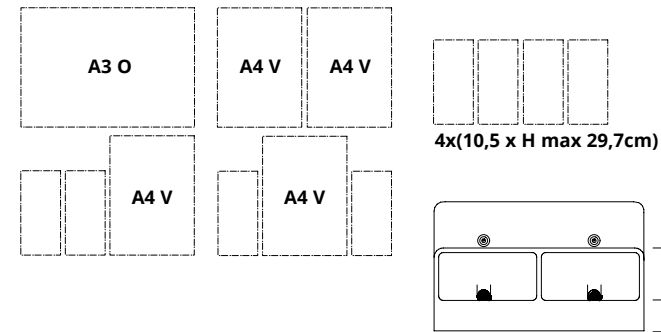

- 1 separatore interno amovibile.
- 1 inner removable divider.
- 1 séparateur interne amovible.
- 1 separador interno amovible.
- 1 innerer entfernbarer Unterteiler.

Espositori in acciaio verniciato e PETG forniti con morsetti grigi.
 Display panels in powder-coated steel and PETG supplied with grey clamps.
 Présentoirs en acier peint et PETG dotés d' étaux gris.
 Expositores en acero pintado y PETG con abrazaderas grises.
 Präsentationsschild aus pulverbeschichtetem Stahl und PETG mit grauen Seilklemmen.





- 3 separatori interni amovibili
- 3 inner removable dividers
- 3 séparateurs internes amovibles
- 3 separadores internos amovibles
- 3 inneren entfernbaren Unterteiler

Espositori in acciaio verniciato e PETG forniti con morsetti grigi.
 Display panels in powder-coated steel and PETG supplied with grey clamps.
 Présentoirs en acier peint et PETG dotés d' étaux gris.
 Expositores en acero pintado y PETG con abrazaderas grises.
 Präsentationsschild aus pulverbeschichtetem Stahl und PETG mit grauen Seilklemmen.

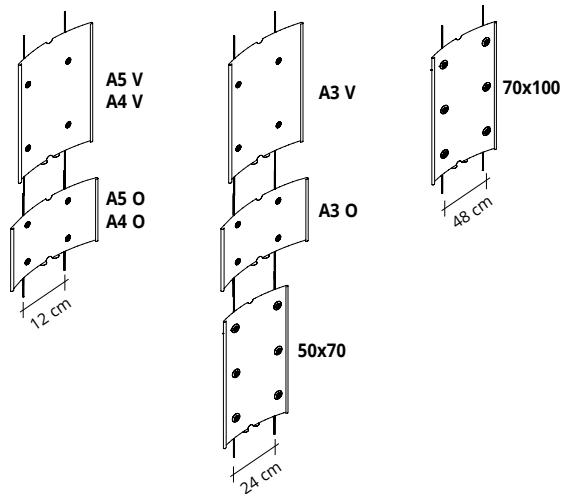

ESPOSITORI CURVI PER CAVI
CURVED DISPLAY PANELS FOR CABLES





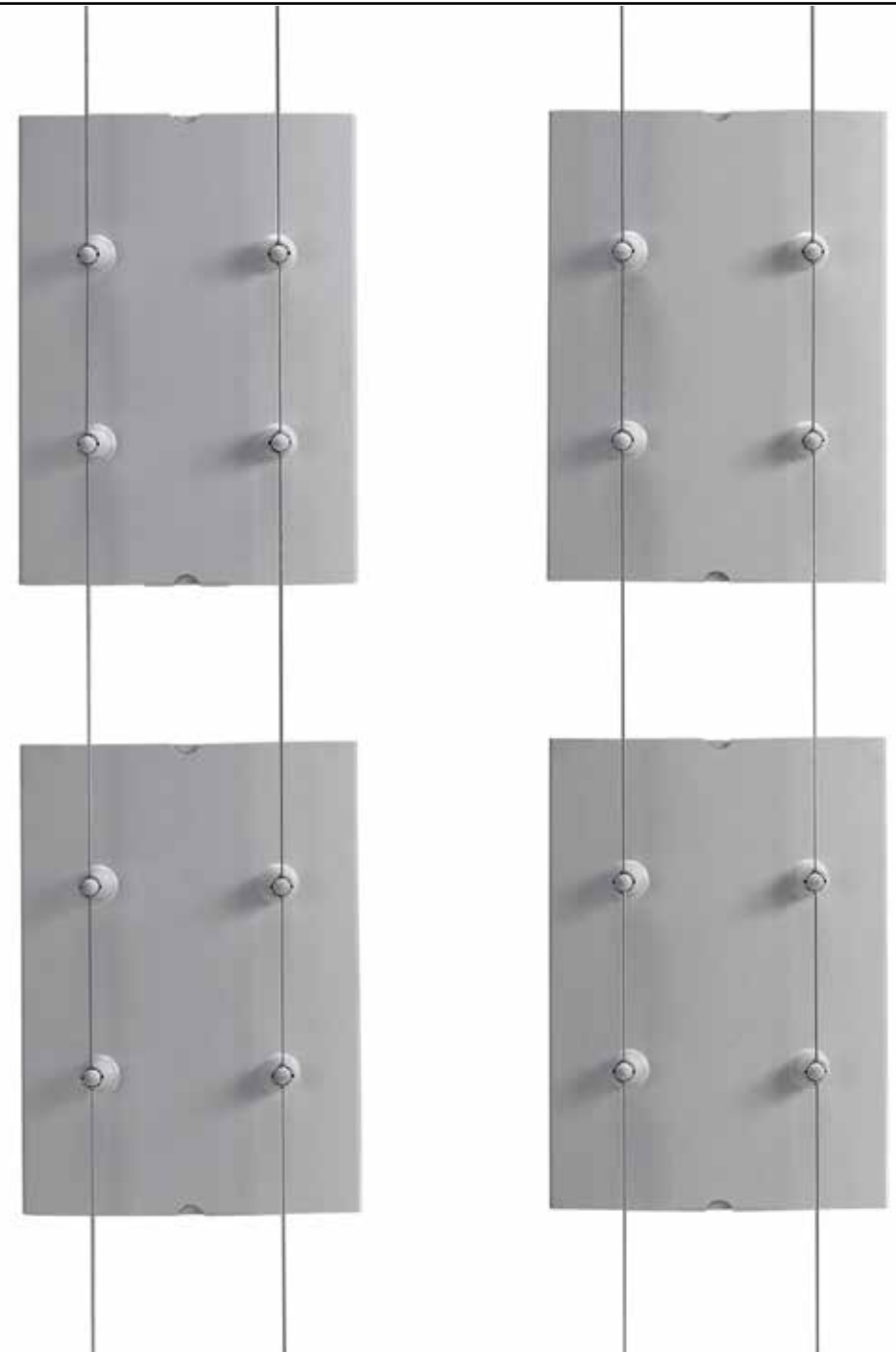





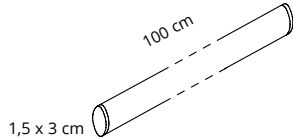

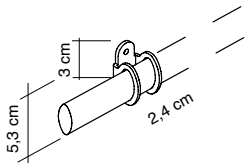

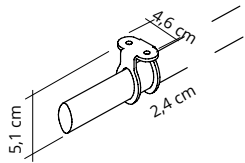





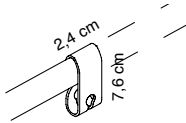

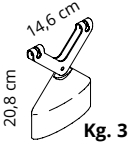

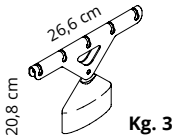







CD.	CL.	FORMATO	PR. €	L cm	H cm	Kg
						
5100-GA	GA	A5 O	45,00	21,5	15,0	0,30
5101-GA	GA	A5 V	45,00	15,5	21,2	0,35
5104-GA	GA	A4 O	55,00	29,9	21,2	0,60
5105-GA	GA	A4 V	55,00	21,5	29,9	0,70
5108-GA	GA	A3 O	79,00	41,6	29,9	1,20
5109-GA	GA	A3 V	79,00	29,5	42,2	1,45
5113-GA	GA	50x70	138,00	51,2	71,2	3,35
5115-GA	GA	70x100	228,00	71,2	101,2	7,40

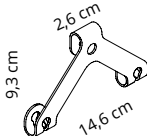

Espositori in acciaio verniciato e PETG forniti con morsetti grigi.
Display panels in powder-coated steel and PETG supplied with grey clamps.
Présentoirs en acier peint et PETG dotés d' étaux gris.
Expositores en acero pintado y PETG con abrazaderas grises.
Präsentationsschild aus pulverbeschichtetem Stahl und PETG mit grauen Seilklemmen.

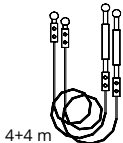

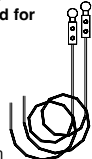
	 	 	 
CD.	5180	5160-GA	5161-GA
PR.	€ 79,00 (2 pcs)	€ 46,00 (2 pcs)	€ 46,00 (2 pcs)
CL.	C	GA	GA
			
DS.	<p>Tubi ellittici in acciaio cromato. Chrome-plated steel elliptical rails. Barres elliptiques en acier chromé. Tubos elípticos en acero cromado. Ovale Stangen aus verchromtem Stahl.</p>	<p>Fissaggi a parete in acciaio verniciato per cod. 5180. Powder-coated steel wall-fix clamps for code 5180. Fixations murales en acier peint pour réf. 5180. Soportes a pared en acero pintado para cod. 5180. Wandbefestigungen aus pulverbeschichtetem Stahl für Art. 5180.</p>	<p>Fissaggi a soffitto/pavimento in acciaio verniciato per cod. 5180. Powder-coated steel floor/ceiling clamps for code 5180. Fixations sol/plafon en acier peint pour réf. 5180. Soportes suelo/techo en acero pintado para cod. 5180. Decken/Bodenfestigungen aus pulverbeschichtetem Stahl für Art. 5180.</p>
	<p>Per formati: For format: Pour format: Para formato: Für Format: A5 A4 A3 50x70 70x100</p>  	<p>Per formati: For format: Pour format: Para formato: Für Format: A5 A4</p>  	<p>Per formati: For format: Pour format: Para formato: Für Format: A5 A4 A3 50x70</p>  
CD.	5166-GA	5146-GA	5147-GA
PR.	€ 34,00 (2 pcs)	€ 98,00	€ 108,00
CL.	GA	GA	GA
			
DS.	<p>Supporti a 1 via in acciaio verniciato per cod. 5180. Powder-coated steel 1-way supports for code 5180. Supports 1 voie en acier peint pour réf. 5180. Soportes de 1 vía en acero pintado para cod. 5180. Befestigungshaken (1-fach) aus pulverbeschichtetem Stahl für Art. 5180.</p>	<p>Supporto a 2 vie con peso in acciaio verniciato. Powder-coated steel 2-ways support with ballast. Support 2 voies avec ballast en acier peint. Soporte a 2 vías con peso en acero pintado. Gewicht mit Befestigung (2-fach), aus pulverbeschichtetem Stahl.</p>	<p>Supporto a 5 vie con peso in acciaio verniciato. Powder-coated steel 5-ways support with ballast. Support 5 voies avec ballast en acier peint. Soporte a 5 vías con peso en acero pintado. Gewicht mit Befestigung (5-fach), aus pulverbeschichtetem Stahl.</p>

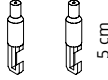
<p>Per formati: For format: Pour format: Para formato: Für Format: A5 A4 A3 50x70 70x100</p>   <p>5158-GA</p>	<p>Per formati: For format: Pour format: Para formato: Für Format: A5 A4 A3 50x70 70x100</p>   <p>5159-GA</p>	<p>Per formati: For format: Pour format: Para formato: Für Format: A5 A4</p>   <p>5140-GA</p>
<p>CD. € 34,00 (2 pcs)</p>	<p>CD. € 34,00 (2 pcs)</p>	<p>CD. € 32,00</p>
<p>PR. GA</p>	<p>PR. GA</p>	<p>PR. GA</p>
<p>CL. </p>	<p>CL. </p>	<p>CL. </p>
<p>DS. Supporti a 1 via in acciaio verniciato per fissaggio a parete. Powder-coated 1-way supports for wall fixing. Supports 1 voie en acier peint pour fixation mural. Soportes a 1 via en acero pintado para fijación a pared. Wandbefestigungen (1-fach) aus pulverbeschichtetem Stahl.</p>	<p>DS. Supporti a 1 via in acciaio verniciato per fissaggio a pavimento/soffitto. Powder-coated steel 1-way supports for floor/ceiling fixing. Supports 1 voie en acier peint pour fixation sol/plafon. Soportes a 1 via en acero pintado para fijación suelo/techo. Decken/Bodenbefestigungen (1-fach) aus pulverbeschichtetem Stahl.</p>	<p>DS. Supporto a 2 vie in acciaio verniciato per fissaggio a parete. Powder-coated steel 2-ways support for wall fixing. Support 2 voies en acier peint pour fixation mural. Soporte a 2 vias en acero pintado para fijación a pared. Wandbefestigung (2-fach) aus pulverbeschichtetem Stahl.</p>
<p> 10 Kg Portata massima Maximum load</p>  <p>4+4 m 5170</p>	<p> 10 Kg Portata massima per ogni cavo Maximum load for each cable</p>  <p>4+4 m 5179</p> <p>Per ref.: For ref.: Pour réf.: Para ref.: Für Art.: 5178</p>	<p>Per ref.: For ref.: Pour réf.: Para ref.: Für Art.: 5179</p>   <p>5178</p>
<p>CD. € 78,00</p>	<p>CD. € 58,00</p>	<p>CD. € 29,00 (2 pcs) C</p>
<p>PR.</p>	<p>PR.</p>	<p>PR.</p>
<p>CL.</p>	<p>CL.</p>	<p>CL.</p>
<p>DS. Cavi d'acciaio (4+4 m) + tiranti. Steel cables (4+4 m) + tension rods. Cables en acier (4+4 m) + tirants. Cables en acero (4+4 m) + pesos. Stahlseile (4+4 m) mit Befestigungsendstücken.</p>	<p>DS. Cavi d'acciaio (4+4 m) per quadri, per cod.: Steel cables (4+4 m) for paintings, for code: Cables en acier (4+4 m) pour tableaux, pour réf.: Cables en acero (4+4 m) para cuadros, para cod.: Stahlseile (4+4 m) für Bilde, für Art.: 5158-GA, 5166-GA</p>	<p>DS. Ganci per quadri con bloccacavo. Hooks for paintings. Crochets pour tableaux. Ganchos para cuadros. Haken für Bilder.</p>

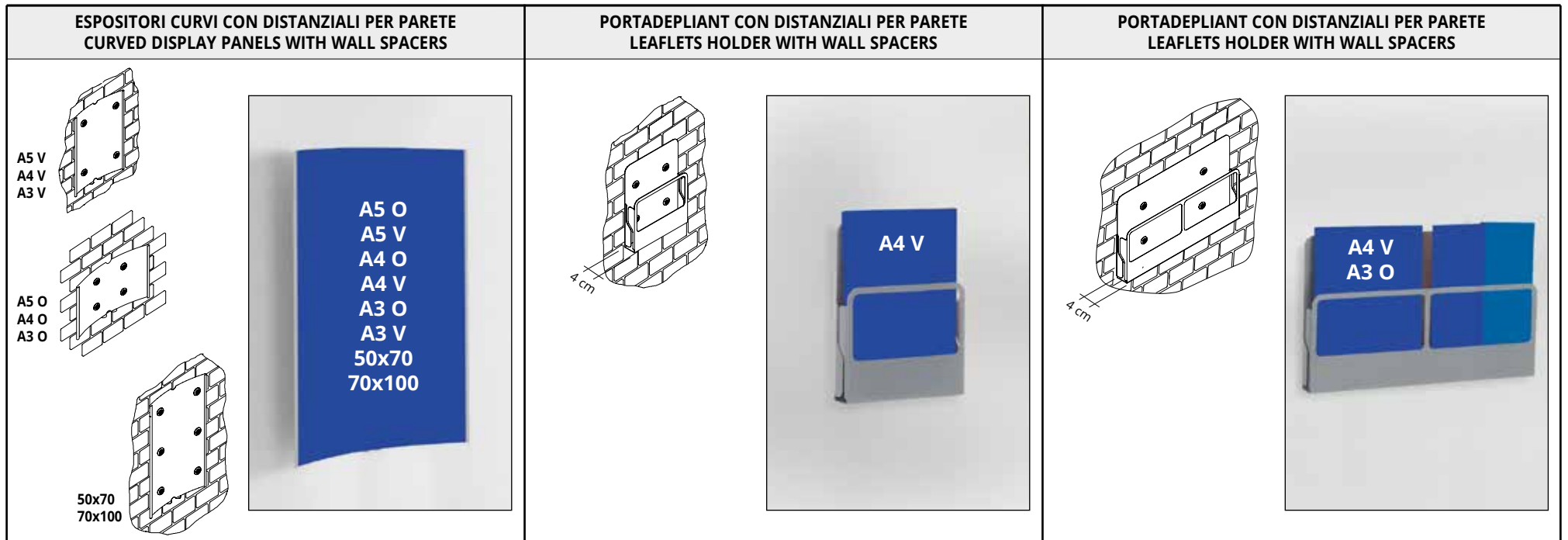

CD.	FORMATO	PR. €	CL.	L cm	H cm	CD.	FORMATO	PR. €	CL.	L cm	H cm	CD.	FORMATO	PR. €	CL.	L cm	H cm	
5130	A5 O	45,00	GA	21,5	15	5185	A4 V	55,00	GA	22	38	5186	A3 O	88,00	GA	46,5	28	
5131	A5 V	45,00	GA	15,5	21,2													
5134	A4 O	55,00	GA	29,5	21,2													
5135	A4 V	55,00	GA	21,5	29,9													
5138	A3 O	79,00	GA	41,6	29,9													
5139	A3 V	79,00	GA	29,9	42,2													
5143	50x70	138,00	GA	51,2	71,2													
5153	70x100	228,00	GA	71,2	101,2													

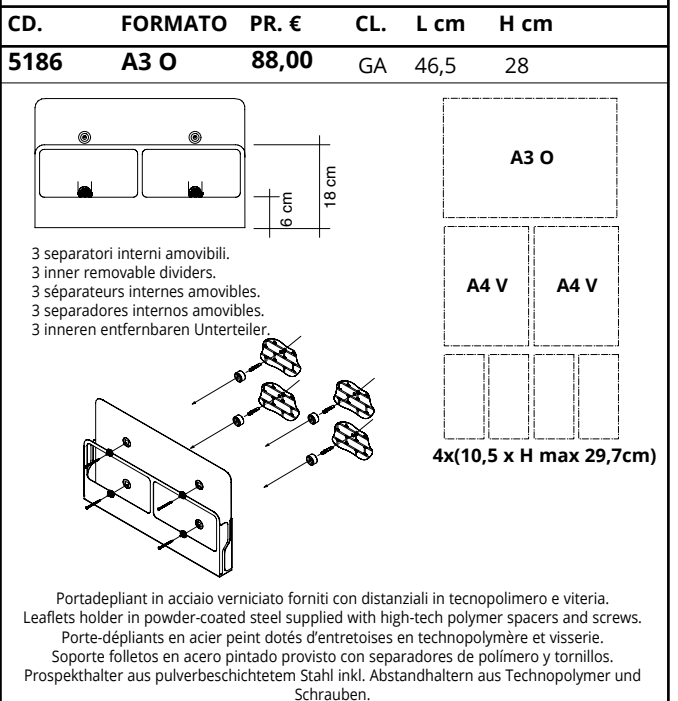
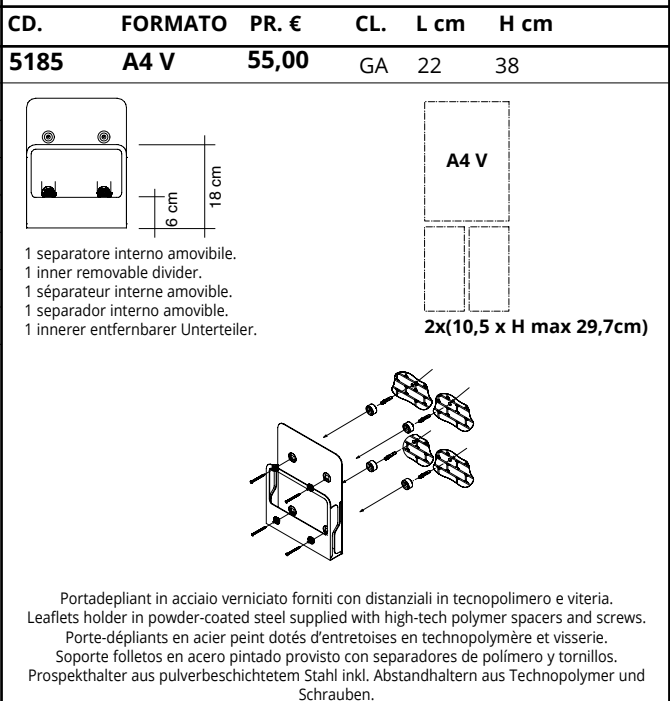
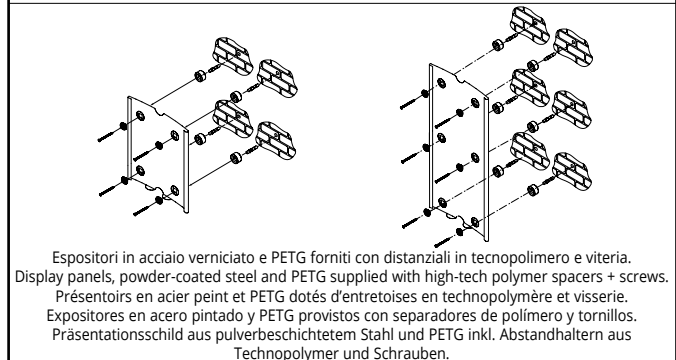

ESPOSITORI CURVI PER PARETE (SENZA DISTANZIALI)
CURVED DISPLAY PANELS FOR WALL (WITHOUT SPACERS)

Nuova Fiera Milano - New Exhibition Center, Milano (Italy)

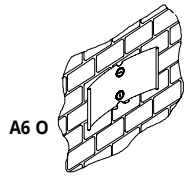

A6 O



CD.	FORMATO	PR. €	CL.	L cm	H cm
5129	A6 O	33,00	GA	15,5	10,5

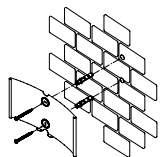

Espositori in acciaio verniciato e PETG forniti con viteria.
Display panels in powder-coated steel and PETG supplied with screws.
Présentoirs en acier peint et PETG fournis avec visserie.
Expositores en acero pintado y PETG provistos de tornillos.
Präsentationschild aus pulverbeschichtetem Stahl und PETG mit Schrauben.

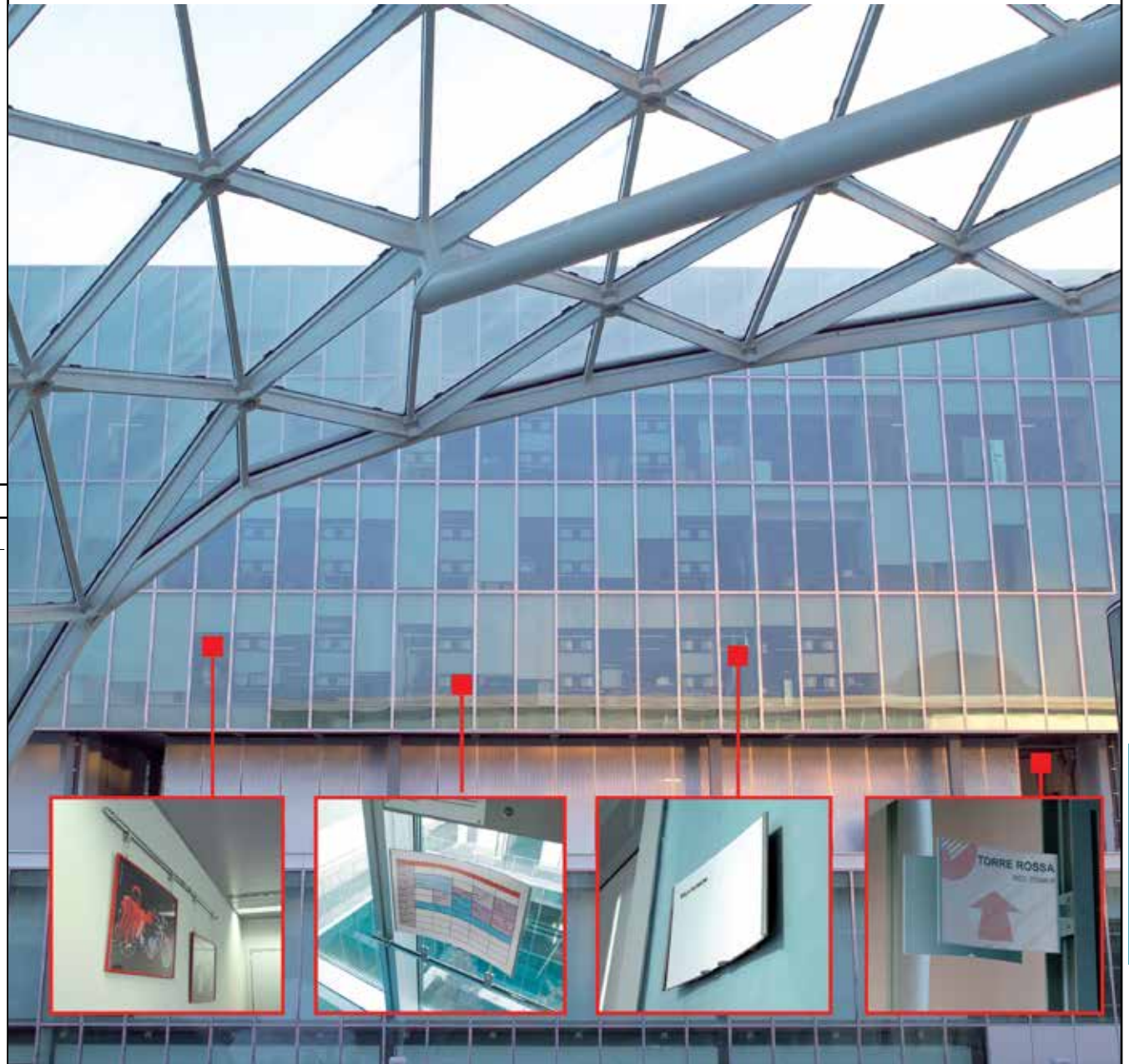

ESPOSITORI CURVI CON PIASTRA E BIADESIVO PER VETRO CURVED DISPLAY PANELS WITH PLATE AND DOUBLE-SIDED ADHESIVE TAPE FOR GLASS WALL

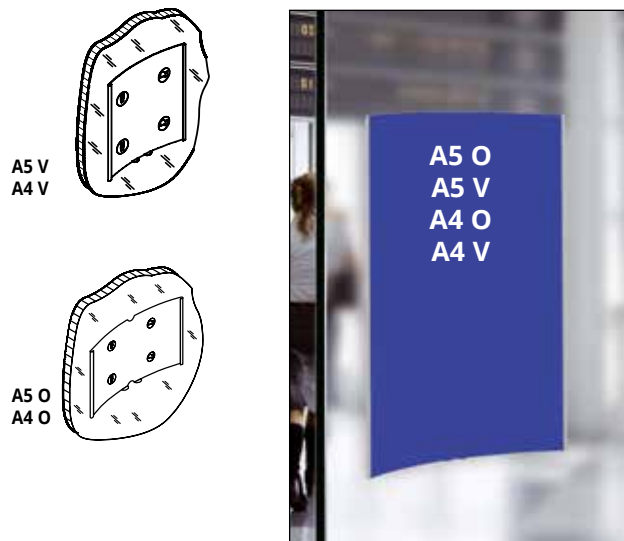

PORTADEPLIANT CON PIASTRA E BIADESIVO PER VETRO LEAFLETS HOLDER WITH PLATE AND DOUBLE-SIDED ADHESIVE TAPE FOR GLASS WALL

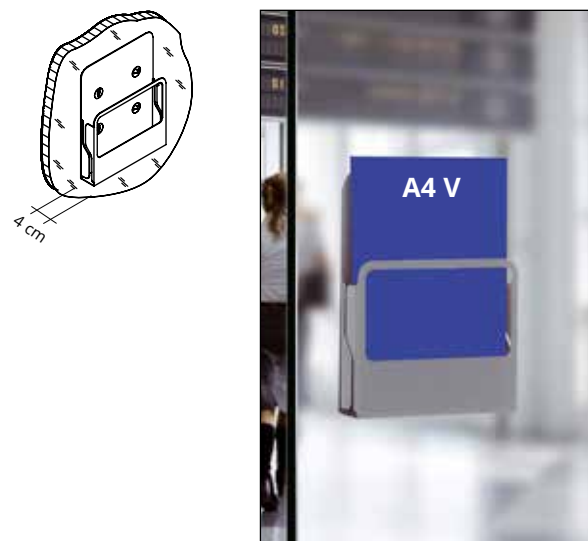

ESPOSITORI CURVI CON BIADESIVO PER VETRO CURVED DISPLAY PANELS WITH DOUBLE-SIDED ADHESIVE TAPE FOR GLASS WALL



CD.	FORMATO	PR. €	CL.	L cm	H cm
5130-BA	A5 O	51,00	GA	21,5	15,0
5131-BA	A5 V	51,00	GA	15,5	21,2
5134-BA	A4 O	61,00	GA	29,9	21,2
5135-BA	A4 V	61,00	GA	21,5	29,9

CD.	FORMATO	PR. €	CL.	L cm	H cm
5185-BA	A4 V	61,00	GA	22	38

CD.	FORMATO	PR. €	CL.	L cm	H cm
5129-BA	A6 O	39,00	GA	15,5	10,5

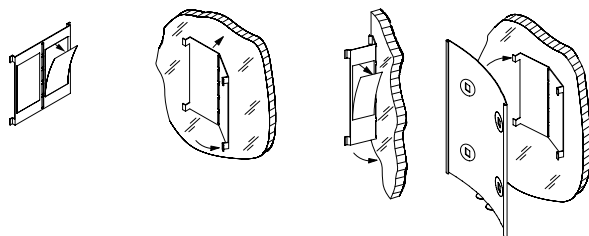

Espositori in acciaio verniciato e PETG forniti con piastra in acciaio e biadesivo.
Display panels powder-coated steel and PETG supplied with steel plate + double-sided adhesive tape.
Présentoirs en acier peint et PETG dotés de platine en acier et bande biadhésive.
Expositores en acero pintado y PETG provisto de una placa de acero y biadesivo.
Präsentationsschild aus pulverbeschichtetem Stahl und PETG inkl. Montageplatte und doppelseitigem Klebeband

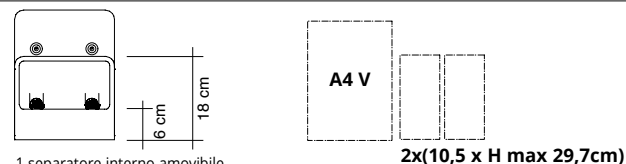

1 separatore interno amovibile.
1 inner removable divider.
1 séparateur interne amovible.
1 separator interno amovible.
1 innerer entfernbarer Unterteiler.

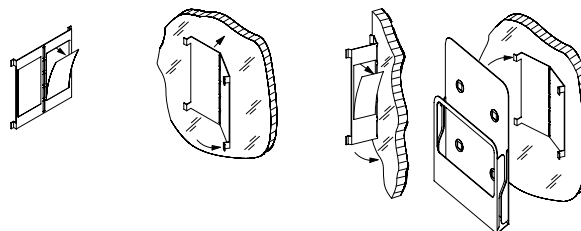

Portadepliant in acciaio verniciato forniti con piastra in acciaio e biadesivo.
Leaflets holder in powder-coated steel supplied with steel plate and double-sided adhesive tape.
Porte-dépliants en acier peint dotés de platine en acier et bande biadhésive.
Soporte folletos en acero pintado provisto de una placa de acero y biadesivo.
Prospekthalter aus pulverbeschichtetem Stahl inkl. Montageplatte und doppelseitigem Klebeband.

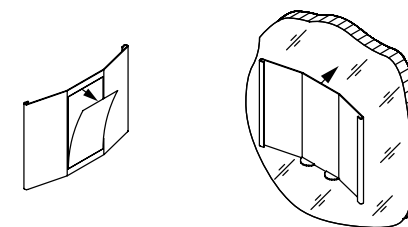

Espositori in acciaio verniciato e PETG forniti con biadesivo.
Display panels in powder-coated steel and PETG supplied with double-sided adhesive tape.
Présentoirs en acier peint et PETG dotés de bande biadhésive.
Expositores en acero pintado y PETG provisto de biadesivo.
Präsentationsschild aus pulverbeschichtetem Stahl und PETG inkl. doppelseitigem Klebeband.

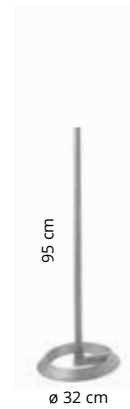

1665

€ 149,00

GA

CD.

PR.

CL.

DS.

Colonnina in acciaio e ghisa verniciati.
 Stanchion made in powder-coated steel and cast iron.
 Colonnette en acier et fonte peints.
 Columna en acero y hierro fundido pintados.
 Standsäule aus pulverbeschichtetem Stahl und Gusseisen.

Espositori monofronte inclinati - Inclined one-sided display panels - Présentoirs inclinés simple face - Expositores monofrontal inclinados - Einseitige, geneigte Präsentationsschilder

Curvo
 Curved
 Courbe
 Curvo
 Gebogen

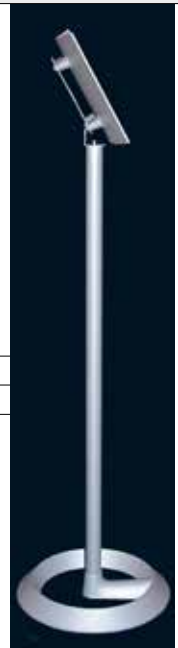
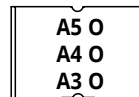
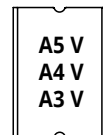
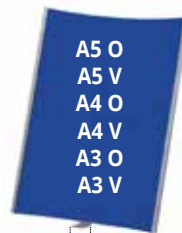

CD.

PR.

CL.

DS.

5100/92	5101/92	5104/92	5105/92	5108/93	5109/93
€ 77,00	€ 77,00	€ 87,00	€ 87,00	€ 111,00	€ 111,00
GA	GA	GA	GA	GA	GA
A5 O	A5 V	A4 O	A4 V	A3 O	A3 V

5195/92
 € 87,00

GA





A4 V / 2x (10,5 x H max 29,7)



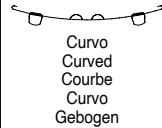

Espositore in acciaio verniciato completo di attacco inclinato e fissaggio su colonnina.
 Display panel in powder-coated steel with inclined connection and fixing on stanchion.
 Présentoir en acier peint avec jonction inclinée et fixation sur colonnette.
 Expositor en acero pintado con conexión inclinada y fijación sobre columna.
 Präsentationsschild aus pulverbeschichtetem Stahl mit geneigter Befestigung auf der Säule.

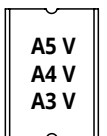
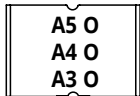
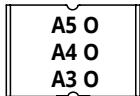
Portadépliant in acciaio verniciato completo di attacco inclinato e fissaggio su colonnina.
 Leaflets holder in powder-coated steel with inclined connection and fixing on stanchion.
 Porte-dépliants en acier peint avec jonction inclinée et fixation sur colonnette.
 Porta folletos en acero pintado con conexión inclinada y fijación sobre columna.
 Prospekthalter aus pulverbeschichtetem Stahl mit geneigter Befestigung auf der Säule.





						
CD.	1670-GAN	1670-GABL	1675-GAN	1675-GABL	1677-N	
PR.	€ 338,00	€ 338,00	€ 168,00	€ 168,00	€ 14,00	
CL.	GA BLACK tape	GA BLUE tape	GA BLACK tape	GA BLUE tape	N	
DS.	Colonnina in acciaio e ghisa verniciati con nastro estensibile. Stanchion made in powder-coated steel and cast iron with retractable tape. Colonnette en acier et fonte peints avec ruban extensible. Columna en acero y hierro fundido pintados con cinta extensible. Absperrpfosten aus pulverbeschichtetem Stahl und Gusseisen mit ausziehbarem Gurtband.		Supporto a parete con nastro estensibile. Wall-mounted head unit with retractable tape. Système de bobinage à fixation murale avec ruban extractible. Enrollador a pared con cinta extensible. Absperrung zur Wandmontage mit ausziehbarem Gurtband.		Attacco a parete. Wall-clip. Fixation mural. Fijación mural. Wandbefestigung.	





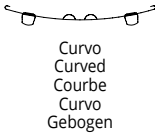

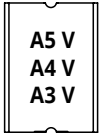

Espositori monofronte inclinati - Inclined one-sided display panels - Présentoirs inclinés simple face - Expositores monofrontal inclinados - Einseitige, geneigte Präsentationsschilder

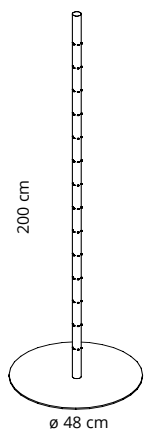
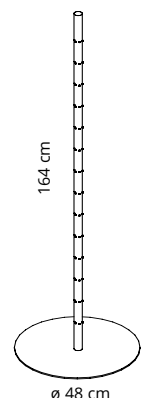
								
	Curvo Curved Courbe Curvo Gebogen							
CD.	5100/92-E	5101/92-E	5104/92-E	5105/92-E	5108/93-E	5109/93-E	5195/92-E	
PR.	€ 93,00	€ 93,00	€ 103,00	€ 103,00	€ 127,00	€ 127,00	€ 103,00	
CL.	GA A5 O	GA A5 V	GA A4 O	GA A4 V	GA A3 O	GA A3 V	GA A4 V / 2x (10,5 x H max 29,7)	
DS.	Espositore in acciaio verniciato completo di attacco inclinato e fissaggio su colonnina. Display panel in powder-coated steel with inclined connection and fixing on stanchion. Présentoir en acier peint avec jonction inclinée et fixation sur colonnette. Expositor en acero pintado con conexión inclinada y fijación sobre columna. Präsentationsschild aus pulverbeschichtetem Stahl mit geneigter Befestigung auf der Säule.						Portadepliant in acciaio verniciato completo di attacco inclinato e fissaggio su colonnina. Leaflets holder in powder-coated steel with inclined connection and fixing on stanchion. Porte-dépliants en acier peint avec jonction inclinée et fixation sur colonnette. Porta folletos en acero pintado con conexión inclinada y fijación sobre columna. Prospekthalter aus pulverbeschichtetem Stahl mit geneigter Befestigung auf der Säule.	



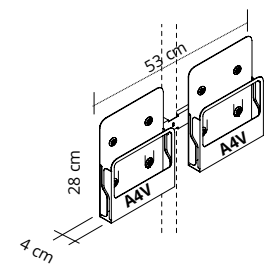

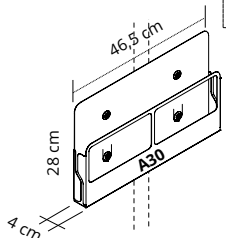
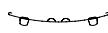
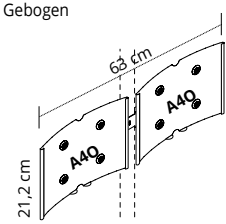
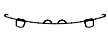
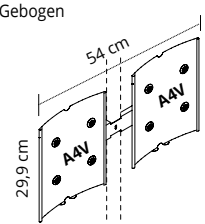
						
CD.	1680 (N)	1680 (GA)	1685 (N)	1685 (R)	1685 (GR)	
PR.	€ 197,00	€ 197,00	€ 128,00	€ 128,00	€ 128,00	
CL.	N	GA	N	R	GR	
DS.	<p>Colonnina in acciaio e ghisa verniciati, dettagli in alluminio lucidato e acciaio cromato. Stanchion made in powder-coated steel and cast iron, details in polished aluminium and chrome-plated steel. Colonnnette en acier et fonte peints, détails en aluminium poli et acier chromé. Columna en acero y hierro fundido pintados, detalles en aluminio pulido y acero cromado. Standsäule aus pulverbeschichtetem Stahl und Gusseisen, Details aus poliertem Aluminium und verchromtem Stahl.</p>		<p>Cordone in tecnopolimero con ganci in metallo cromato. High-tech polymer cord with chrome-plated metal hooks. Cordon en technopolymère avec crochets en métal chromé. Cordon en tecnopolimero con ganchos de metal cromados. Kordel aus Technopolymer mit Haken aus verchromtem Metall.</p>			

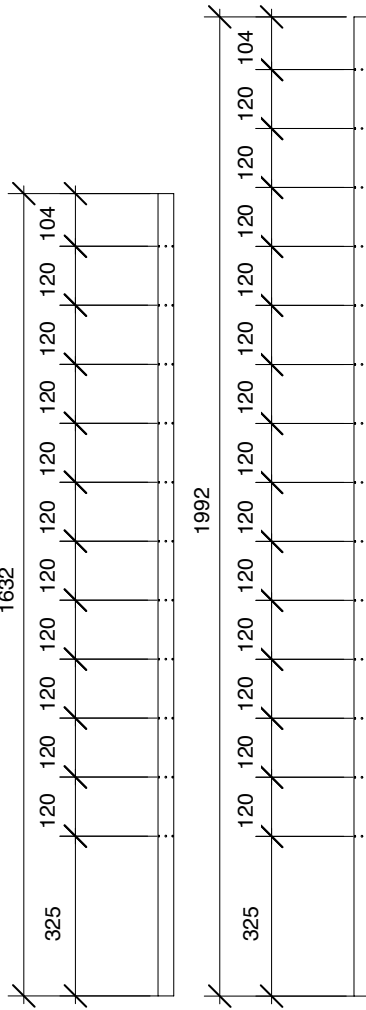

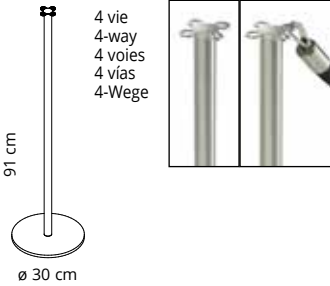

Espositori monofronte inclinati - Inclined one-sided display panels - Présentoirs inclinés simple face - Expositores monofrontal inclinados - Einseitige, geneigte Präsentationsschilder

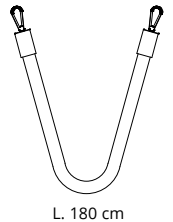

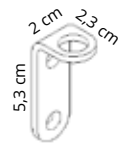

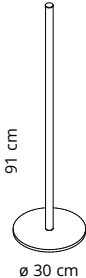
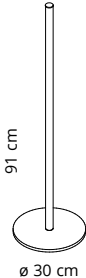
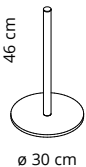
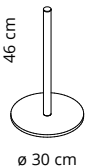

								
	Curvo Curved Courbe Curvo Gebogen	A5 O A5 V A4 O A4 V A3 O A3 V	A5 V A4 V A3 V	A4 V				
CD.	5100/92-C	5101/92-C	5104/92-C	5105/92-C		5108/93-C	5109/93-C	5195/92-C
PR.	€ 90,00	€ 90,00	€ 100,00	€ 100,00		€ 124,00	€ 124,00	€ 100,00
CL.	GA	GA	GA	GA		GA	GA	GA
	A5 O	A5 V	A4 O	A4 V	A3 O	A3 V	A4 V / 2x (10,5 x H max 29,7)	
DS.	<p>Espositore in acciaio verniciato completo di attacco inclinato e fissaggio su colonnina. Display panel in powder-coated steel with inclined connection and fixing on stanchion. Présentoir en acier peint avec jonction inclinée et fixation sur colonnette. Expositor en acero pintado con conexión inclinada y fijación sobre columna. Präsentationsschild aus pulverbeschichtetem Stahl mit geneigter Befestigung auf der Säule.</p>						<p>Portadepliant in acciaio verniciato completo di attacco inclinato e fissaggio su colonnina. Leaflets holder in powder-coated steel with inclined connection and fixing on stanchion. Porte-dépliants en acier peint avec jonction inclinée et fixation sur colonnette. Porta folletos en acero pintado con conexión inclinada y fijación sobre columna. Prospekthalter aus pulverbeschichtetem Stahl mit geneigter Befestigung auf der Säule.</p>	

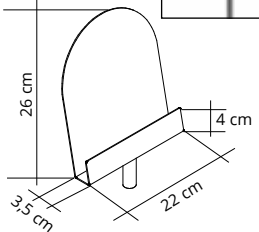
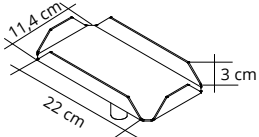
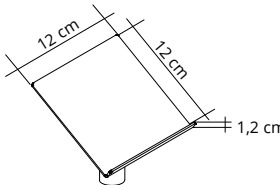
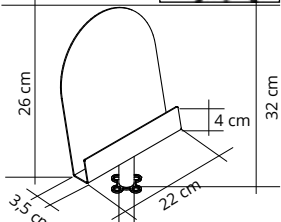
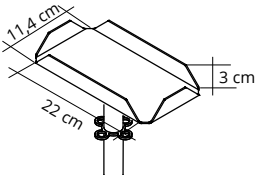
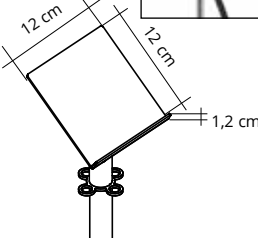
<p>CD. PR. CL. DS.</p>	 <p>5025 € 198,00 GA</p>	 <p>5023 € 188,00 GA</p>	 	
<p>Montante e base in acciaio verniciato. Powder-coated steel post and base. Montant et base en acier peint. Lateral y base en acero pintado. Standssäule und Fuß aus pulverbeschichtetem Stahl.</p>				
<p>CD. PR. CL. DS.</p>	<p>A4, 2x(10,5 x H max 29,7cm)</p>   <p>5040 € 158,00 GA</p> <p>Coppia portadepliant + supporto in acciaio verniciato. 2 leaflets holder + support in powder-coated steel. 2 porte-dépliants + support en acier peint. 2 porta folletos + soporte en acero pintado. 2 Prospekthalter + Halterung aus pulverbeschichtetem Stahl.</p>	<p>A3, 2xA4, 4x(10,5 x H max 29,7cm)</p>   <p>5041 € 138,00 GA</p> <p>Portadepliant con supporti in acciaio verniciato. Leaflets holder with supports in powder-coated steel. Porte-dépliants avec supports en acier peint. Porta folletos con soportes en acero pintado. Prospekthalter mit Halterung aus pulverbeschichtetem Stahl.</p>	<p>A40</p>   <p>5034 € 157,00 GA</p> <p>Coppia espositori + supporto in acciaio verniciato. Pair of display panels + support in powder-coated steel. Paire de présentoirs + support en acier peint. Par de expositores + soportes de acero pintado. Paar Präsentationsschilder + Halterung aus pulverbeschichtetem Stahl.</p>	<p>A4V</p>   <p>5035 € 157,00 GA</p> <p>Coppia espositori + supporto in acciaio verniciato. Pair of display panels + support in powder-coated steel. Paire de présentoirs + support en acier peint. Par de expositores + soportes de acero pintado. Paar Präsentationsschilder + Halterung aus pulverbeschichtetem Stahl.</p>  
				

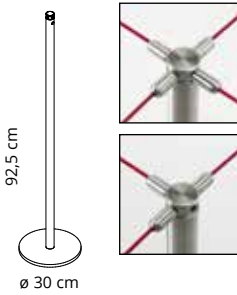
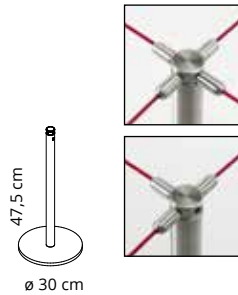
<p>A3O</p> <p>Curvo Curved Courbe Curvo Gebogen</p>	<p>A3V</p> <p>Curvo Curved Courbe Curvo Gebogen</p>	<p>50x70</p> <p>Curvo Curved Courbe Curvo Gebogen</p>	<p>70x100</p> <p>Curvo Curved Courbe Curvo Gebogen</p>	
<p>CD.</p> <p>5038</p>	<p>5039</p>	<p>5043</p>	<p>5044</p>	
<p>PR.</p> <p>€ 138,00</p>	<p>€ 138,00</p>	<p>€ 198,00</p>	<p>€ 320,00</p>	
<p>CL.</p> <p>GA</p>	<p>GA</p>	<p>GA</p>	<p>GA</p>	
<p>DS.</p> <p>Espositore + supporto in acciaio verniciato. Display panel + support in powder-coated steel. Présentoir + support en acier peint. Expositor + soportes de acero pintado. Präsentationsschild + Halterung aus pulverbeschichtetem Stahl.</p>				
<p>50x70</p> <p>ø 48 x h 164 cm</p> <p>KOA30-GA</p>	<p>A3 O</p> <p>ø 48 x h 164 cm</p> <p>KOA28-GA</p>	<p>50x70</p> <p>A3 O</p> <p>ø 48 x h 164 cm</p> <p>KOA29-GA</p>	<p>A4 V</p> <p>ø 48 x h 164 cm</p> <p>KOA27-GA</p>	<p>50x70</p> <p>ø 48 x h 200 cm</p> <p>KOA31-GA</p>
<p>CD.</p> <p>€ 386,00</p>	<p>€ 602,00</p>	<p>€ 524,00</p>	<p>€ 662,00</p>	<p>€ 594,00</p>
<p>PR.</p>	<p>€ 602,00</p>	<p>€ 524,00</p>	<p>€ 662,00</p>	<p>€ 594,00</p>
<p>DS.</p> <p>1x 5023 1x 5043 (50x70)</p> <p>Totem con espositore 50x70. Totem with display panel 50x70. Totem avec présentoir 50x70. Totem con expositor 50x70. Totem mit Präsentationsschild 50x70.</p>	<p>1x 5023 3x 5041 (A3 O)</p> <p>Totem con portadepliant A3 O. Totem with leaflets holder A3 O. Totem avec porte-dépliants A3 O. Totem con porta folletos A3 O. Totem mit Prospekthalter A3 O.</p>	<p>1x 5023 1x 5043 (50x70) 1x 5041 (A3 O)</p> <p>Totem con espositore 50x70 e portadepliant A3 O. Totem with display panel 50x70 and leaflet-holder A3 O. Totem avec présentoir 50x70 et porte-dépliants A3 O. Totem con expositor 50x70 y porta folletos A3 O. Totem mit Präsentationsschild 50x70 und Prospekthalter A3 O.</p>	<p>1x 5023 3x 5040 (A4 V)</p> <p>Totem con portadepliant A4 V. Totem with leaflets holder A4 V. Totem avec porte-dépliants A4 V. Totem con porta folletos A4 V. Totem mit Prospekthalter A4 V.</p>	<p>1x 5025 2x 5043 (50x70)</p> <p>Totem con espositori 50x70. Totem with display panels 50x70. Totem avec présentoirs 50x70. Totem con expositor 50x70. Totem mit Präsentationsschilder 50x70.</p>

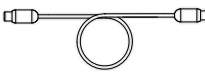
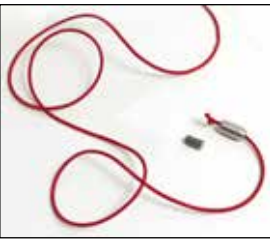
		
CD.	<p>1SECBA6-IN</p>	<p>1SECBA6-I</p>
PR.	<p>€ 128,00</p>	<p>€ 168,00</p>
CL.	<p>I/N</p>	<p>I</p>
		
DS.	<p>Colonnina in acciaio inossidabile satinato, base in acciaio con rivestimento superiore in acciaio inossidabile satinato o verniciato con polveri epossidiche nero gofrato. Completa di attacco per 4 cordoni in acciaio inossidabile satinato. Pole made of satin stainless steel; steel base with satin stainless steel finish or powder-coated embossed black finish. With attachment mechanism for 4 ropes in satin stainless steel. Colonnette en acier inox satiné, pied en acier avec finition inox satiné ou peint en époxy noir gaufré. Avec attache pour 4 cordons réalisée en acier inox satiné. Poste en acero inoxidable satinado, base de acero con revestimiento superior en acero inoxidable satinado o pintado con polvos epoxy en negro gofrado. Con fijación para 4 cordones realizada en acero inoxidable satinado. Standsäule aus mattem Edelstahl, Bodenplatte aus Stahl, mit Beschichtung aus mattem Edelstahl oder mit Epoxidpulverlackierung in geprägtem Schwarz. Mit Haken für 4 Kordeln aus mattem Edelstahl.</p>	
		 
CD.	<p>1SECR1-N</p>	<p>1SEA4-I</p>
PR.	<p>€ 99,00</p>	<p>€ 23,00</p>
CL.	<p>N</p>	<p>I</p>
DS.	<p>Cordone con moschettoni terminali in metallo satinato. Rope with satin-metal carabiner end fittings. Cordon avec mousquetons d'extrémité en métal satiné. Cordón rematado con mosquetones en metal satinado. Kordel mit Karabiner aus mattem Metall.</p> <p>Per cod. / For codes / Pour codes / Para codigos / Für Art. 1SECBA6-I / 1SECBA6-IN / 1SEA4-I / 1SEFG7-IN / 1SEFG8-IN / 1SEFG9-IN</p>	<p>Attacco a parete per cordone in acciaio inox satinato. Satin stainless steel finish wall attachment for rope. Fixation murale pour cordon en acier inox satiné. Fijación a pared para el cordón en acero inoxidable satinado. Wandbefestigung für Kordel aus mattem Edelstahl.</p> <p>Per cod. / For codes / Pour codes / Para codigos / Für Art. 1SECR1-N</p>

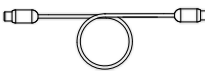
						
CD.	1SECB5-IN	1SECB5-I	1SECB6-IN	1SECB6-I		
PR.	€ 108,00	€ 148,00	€ 99,00	€ 139,00		
CL.	I/N	I	I/N	I		
						
DS.	<p>Colonnina in acciaio inossidabile satinato, base in acciaio con rivestimento superiore in acciaio inossidabile satinato o verniciato con polveri epossidiche nero gofrato. Pole made of satin stainless steel; steel base with satin stainless steel finish or powder-coated embossed black finish. Colonnnette en acier inox satiné, pied en acier avec finition inox satiné ou peint en époxy noir gaufré. Poste en acero inoxidable satinado, base de acero con revestimiento superior en acero inoxidable satinado o pintado con polvos epoxy en negro gofrado. Standsäule aus mattem Edelstahl, Bodenplatte aus Stahl, mit Beschichtung aus mattem Edelstahl oder mit Epoxidpulverlackierung in geprägtem Schwarz.</p>					
						
CD.	1SEF3-NB	1SEF2-NB	1SEF4-NB	1SEFG7-IN	1SEFG8-IN	1SEFG9-IN
PR.	€ 53,00	€ 53,00	€ 52,00	€ 98,00	€ 98,00	€ 97,00
CL.	N	N	N	I/N	I/N	I/N
DS.	<p>Espositore / portadepliant in acciaio verniciato con polveri epossidiche nero gofrato. Display unit/brochure and leaflet-holder made of epoxy powder-coated steel in embossed black. Présentoir / porte-brochure en acier verni poudre époxy noir gaufré. Expositor / portafolletos en acero barnizado con polvos epoxy en negro gofrado. Infotafel / Broschürenhalter aus Stahl mit Epoxidpulverlackierung in geprägtem Schwarz.</p> <p>Per cod. / For codes / Pour codes / Para codigos / Für Art. 1SECB5-I / 1SECB5-IN / 1SECB6-I / 1SECB6-IN</p>			<p>Espositore / portadepliant in acciaio verniciato con polveri epossidiche nero gofrato. Con attacco per 4 cordoni realizzato in acciaio inossidabile satinato. Display unit/brochure and leaflet-holder made of epoxy powder-coated steel in embossed black. With satin stainless steel attachment mechanism for 4 ropes. Présentoir / porte-brochure en acier verni poudre époxy noir gaufré. Avec attache pour 4 cordons réalisé en acier inox satiné. Expositor / portafolletos en acero barnizado con polvos epoxy negro gofrado. Con fijación para 4 cordones en acero inoxidable satinado. Infotafel / Broschürenhalter aus Stahl mit Epoxidpulverlackierung in geprägtem Schwarz. Mit Haken für 4 Kordeln aus mattem Edelstahl.</p> <p>Per cod. / For codes / Pour codes / Para codigos / Für Art. 1SECB5-I / 1SECB5-IN / 1SECB6-I / 1SECB6-IN</p>		

	 <p>92,5 cm ø 30 cm</p> <p>1/2/3/4 vie 1/2/3/4-way 1/2/3/4 voies 1/2/3/4 vías 1/2/3/4-Wege</p>	 <p>47,5 cm ø 30 cm</p> <p>1/2/3/4 vie 1/2/3/4-way 1/2/3/4 voies 1/2/3/4 vías 1/2/3/4-Wege</p>
CD.	<p>1SECBA8-IN</p>	<p>1SECBA8-I</p>
PR.	<p>€ 167,00</p>	<p>€ 187,00</p>
CL.	<p>I/N</p>	<p>I</p>
		
DS.	<p>Colonnina in acciaio inossidabile satinato, base in acciaio con rivestimento superiore in acciaio inossidabile satinato o verniciato con polveri epossidiche nero gofrato. Con elemento con 4 attacchi filettati per l'aggancio di corde elastiche. Realizzato in acciaio inox satinato.</p> <p>Pole made of satin stainless steel; steel base with satin stainless steel finish or powder-coated embossed black finish. With element made of satin stainless steel with 4 threaded slots for the attachment of elastic ropes. Realized in acciaio inox satinato.</p> <p>Colonnette en acier inox satiné, pied en acier avec finition inox satiné ou peint en époxy noir gaufré. Complet d'élément avec 4 attaches filettées pour la fixation de cordes élastiques. Réalisé en acier inox satiné.</p> <p>Poste en acero inoxidable satinado, base de acero con revestimiento superior en acero inox satinado o pintado con polvos epoxy negro gofrado. Con elemento con 4 fijaciones enroscaadas para el enganche de cintas elásticas. Realizado en acero inoxidable satinado.</p> <p>Standsäule aus mattem Edelstahl, Bodenplatte aus Stahl, mit Beschichtung aus mattem Edelstahl oder mit Epoxidpulverlackierung in geprägtem Schwarz. Mit Element mit 4 Vorrichtungen für das Einhängen von Expanderseilen. Aus mattem Edelstahl.</p>	
	 <p>L. 200 cm</p>  <p>1SEE1-R</p>	 <p>93 cm ø 30 cm</p> <p>1SECBA7-IN</p> <p>1SECBA7-I</p>
CD.	<p>1SEE1-R</p>	<p>1SECBA7-IN</p>
PR.	<p>€ 67,00</p>	<p>€ 218,00</p>
CL.	<p>R</p>	<p>I/N</p>
		
DS.	<p>Corda elastica con attacchi terminali a vite in acciaio e acciaio inox. Elastic rope with screw-in end fitting made of steel / stainless steel. Corde élastique avec attaches d'extrémité à vis en acier et acier inox. Cinta elástica rematada con fijaciones de rosca en acero y acero inoxidable. Expanderseil mit schraubenförmigen Enden aus Stahl und Edelstahl.</p> <p>Per cod. / For codes / Pour codes / Para codigos / Für Art. 1SECBA8-I / 1SECBA8-IN / 1SECBA9-I / 1SECBA9-IN</p> <p>Colonnina in acciaio inossidabile satinato, con portaborse e porta buste per ombrelli realizzato in acciaio inossidabile satinato. Pole made of satin stainless steel with bag holder and umbrella bag holder made of satin stainless steel. Colonnette en acier inox satiné avec porte-sac et porte-housse pour parapluies réalisés en acier inox satiné. Poste en acero inoxidable satinado con percha para bolsos y fundas de paraguas en acero inoxidable satinado. Standsäule aus mattem Edelstahl mit Taschenhalter und Regenschirmbeutelspender aus mattem Edelstahl.</p>	

GASTONE

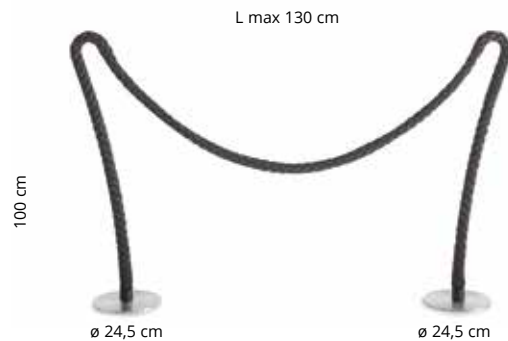

CD.

1650-NI

PR.

€ 480,00



CL.

I/N

DS.

Divisorio con colonnine laterali in acciaio ricoperte e collegate da un unico cordone flessibile in tecnopolimero. Basi in acciaio inox massiccio.
 Room divider with steel side stanchions covered and connected by a single flexible technopolymer cord. Solid stainless steel bases.
 Élément de séparation avec des colonnes latérales en acier recouvertes et liées à un seul cordon flexible en technopolymère. Bases en acier inoxydable massif.
 Elemento separador con montantes laterales de acero revestidos y conectados con un cordón flexible único de tecnopolimero. Bases de acero inoxidable macizo.
 Trennelement mit seitlichen überzogenen Stahlständern, welche durch ein einziges flexibles Seil aus technischem Kunststoff verbunden werden. Die Ständer sind aus massivem Edelstahl.

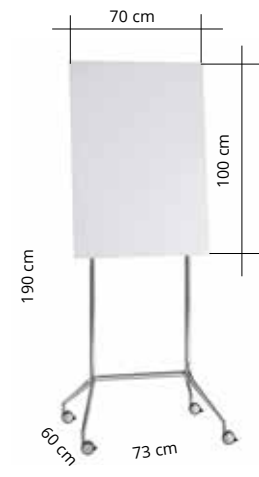
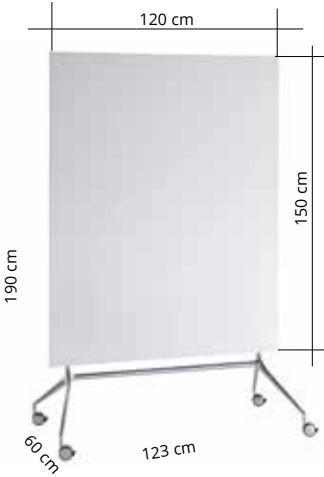
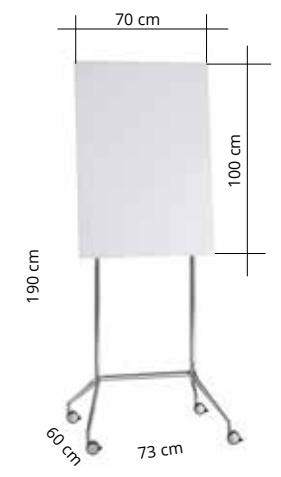
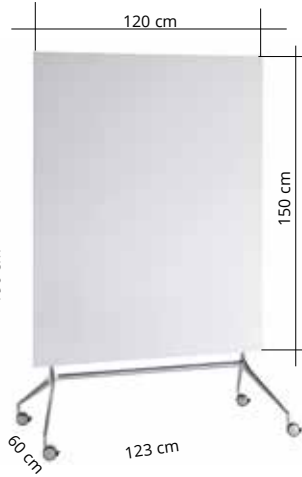

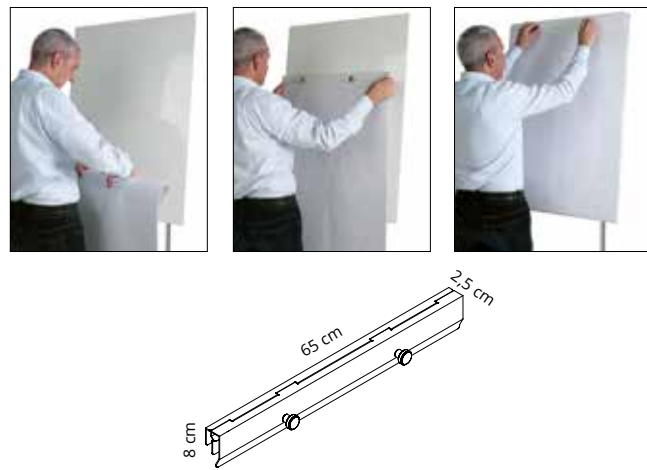
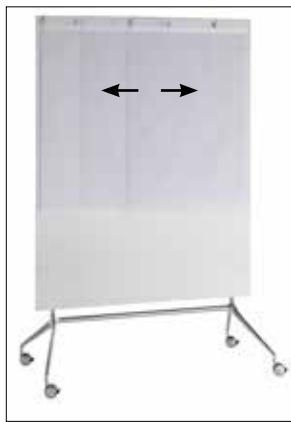
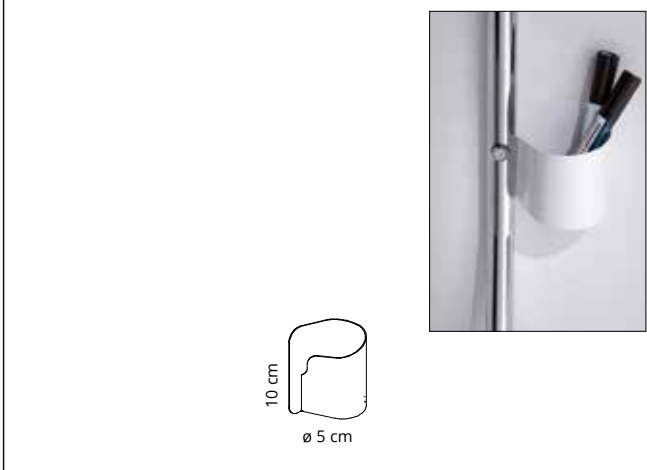
 <p>1SL0710-C</p>	 <p>1SL1215-C</p>	 <p>1SLM0710-C</p>	 <p>1SLM1215-C</p>
<p>CD. 1SL0710-C</p> <p>PR. € 796,00</p> <p>CL. C</p>	<p>CD. 1SL1215-C</p> <p>PR. € 1.150,00</p> <p>CL. C</p>	<p>CD. 1SLM0710-C</p> <p>PR. € 978,00</p> <p>CL. C</p>	<p>CD. 1SLM1215-C</p> <p>PR. € 1.530,00</p> <p>CL. C</p>
<p>DS. Piano scrivibile in laminato colore bianco, con basi in alluminio lucidato montata su ruote con freno e struttura portante in acciaio cromato Writable laminate white top, with polished aluminum bases mounted on casters with stoppers and chrome-plated steel support structure Surface inscriptible en stratifié blanc, avec bases en aluminium poli montée sur des roulettes avec frein et structure portante en acier chromé Tablero de escritura en laminado blanco, con bases de aluminio brillante montada sobre ruedas con freno y estructura portante de acero cromado Schreibtafel aus weißem Laminat, Untergestell aus poliertem Aluminium auf Rollen mit Bremsen und Halterung aus verchromtem Stahl</p>		<p>DS. Piano scrivibile MAGNETICO in laminato colore bianco, con basi in alluminio lucidato montata su ruote con freno e struttura portante in acciaio cromato Writable MAGNETIC laminate top, with polished aluminum bases mounted on casters with stoppers and chrome-plated steel support structure Surface inscriptible MAGNETIQUE en stratifié blanc, avec bases en aluminium poli sur des roulettes avec frein et structure portante en acier chromé Tablero de escritura MAGNÉTICO en laminado blanco, con bases de aluminio brillante con ruedas con freno y estructura portante de acero cromado MAGNETISCH Schreibtafel aus weißem Laminat, Untergestell aus poliertem Aluminium auf Rollen mit Bremsen und Halterung aus verchromtem Stahl</p>	
	 <p>1ME204</p>		 <p>1SL/PP-BO</p>
<p>CD.</p> <p>PR. € 168,00</p> <p>CL. BO</p>	<p>CD.</p> <p>PR. € 168,00</p> <p>CL. BO</p>	<p>CD.</p> <p>PR. € 49,00</p> <p>CL. BO</p>	<p>CD.</p> <p>PR. € 49,00</p> <p>CL. BO</p>
<p>DS. Supporto asportabile in acciaio verniciato con dettagli in alluminio per blocchi carta (non inclusi) Removable support in powder coated steel with aluminium details for notebooks (not included) Support amovible en acier peint avec détails en aluminium pour bloc-papier (pas inclus) Acero pintado soporte extraíble con detalles de aluminio para blocs de papel (no incluidas) Abnehmbarer Halter aus beschichtetem Stahl mit Aluminiumdetails für Papierblock (nicht enthalten)</p>		<p>DS. Portapennarelli in acciaio verniciato con polveri epossidiche Powder-coated steel penholder Porte-stylo en acier peint en époxy Portalápices en acero pintado con polvos epoxídicos Stiftablage aus pulverbeschichtetem Stahl</p>	

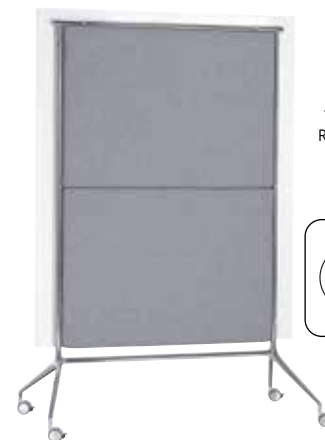
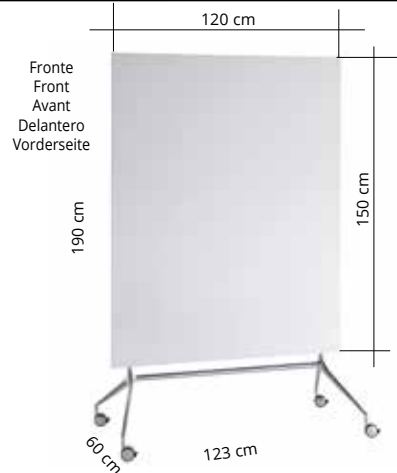

**SOUND ABSORBING
PANELS**



Tessuto asportabile e lavabile
Removable and washable fabric
Tissu amovible et lavable
Tejido extraíble y lavable
Abnehmbares und waschbares Gewebe
Snowsound Fiber Textiles 3 - 300

CD.

1SL1216-C

PR.

€ 1.600,00

CL.

C

DS.

Piano scrivibile in laminato colore bianco, con basi in alluminio lucidato montata su ruote con freno e struttura portante in acciaio cromato. Con elemento fonoassorbente in tessuto acustico Snowsound Fiber Textiles con imbottitura in fibre di poliestere.
Writable laminate white top, with polished aluminum bases mounted on casters with stoppers and chrome-plated steel support structure. Fitted with a sound-absorbing sheet made from Snowsound Fiber Textiles with polyester fiber padding.
Surface inscriptible en stratifié blanc, avec bases en aluminium poli montée sur des roulettes avec frein et structure portante en acier chromé. Complétées par un élément anti-bruit en tissu acoustique Snowsound Fiber Textiles avec rembourrage en fibres de polyester.
Tablero de escritura en laminado blanco, con bases de aluminio brillante montada sobre ruedas con freno y estructura portante de acero cromado. Completado con un elemento fonoabsorbente de tejido acústico Snowsound Fiber Textiles acolchado de fibras de poliéster.
Schreibtafeln aus weißem Laminat, Untergestell aus poliertem Aluminium auf Rollen mit Bremsen und Halterung aus verchromtem Stahl. Die Schreibflächen können durch eine mit Polyester gefüllte Schalldämpf-Platte aus Snowsound-Fiber-Textiles-Gewebe versehen werden

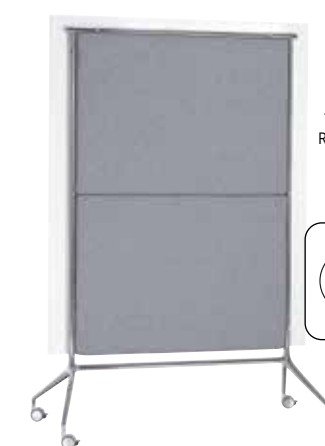
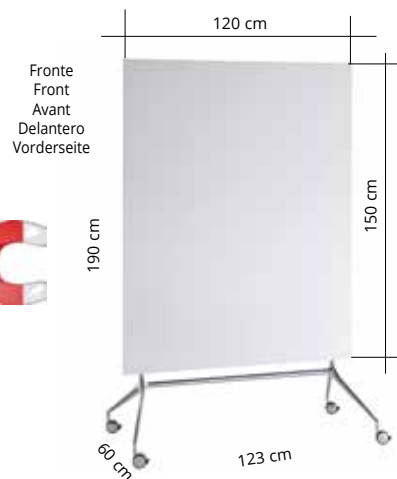

**SOUND ABSORBING
PANELS**



Tessuto asportabile e lavabile
Removable and washable fabric
Tissu amovible et lavable
Tejido extraíble y lavable
Abnehmbares und waschbares Gewebe
Snowsound Fiber Textiles 3 - 300

CD.

1SLM1216-C

PR.



€ 1.980,00



CL.

C

DS.

Piano scrivibile MAGNETICO in laminato colore bianco, con basi in alluminio lucidato montata su ruote con freno e struttura portante in acciaio cromato. Con elemento fonoassorbente in tessuto acustico Snowsound Fiber Textiles con imbottitura in fibre di poliestere.
Writable MAGNETIC laminate top, with polished aluminum bases mounted on casters with stoppers and chrome-plated steel support structure. Fitted with a sound-absorbing sheet made from Snowsound Fiber Textiles with polyester fiber padding.
Surface inscriptible MAGNETIQUE en stratifié blanc, avec bases en aluminium poli sur des roulettes avec frein et structure portante en acier chromé. Complétées par un élément anti-bruit en tissu acoustique Snowsound Fiber Textiles avec rembourrage en fibres de polyester.
Tablero de escritura MAGNÉTICO en laminado blanco, con bases de aluminio brillante con ruedas con freno y estructura portante de acero cromado. Completado con un elemento fonoabsorbente de tejido acústico Snowsound Fiber Textiles acolchado de fibras de poliéster.
MAGNETISCH Schreibtafeln aus weißem Laminat, Untergestell aus poliertem Aluminium auf Rollen mit Bremsen und Halterung aus verchromtem Stahl. Die Schreibflächen können durch eine mit Polyester gefüllte Schalldämpf-Platte aus Snowsound-Fiber-Textiles-Gewebe versehen werden.

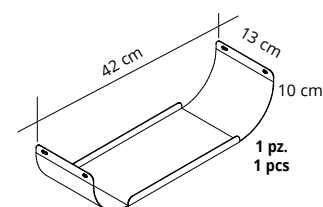
	 <p>1SP07-CBO € 758,00</p>	
CD.		
PR.		
CL.	BO	
DS.	<p>Leggio in alluminio verniciato con polveri epossidiche, con basi in alluminio lucidato montata su ruote con freno e struttura portante in acciaio cromato. Bookstand in powder-coated aluminum, with polished aluminium bases mounted on casters with stoppers and chrome-plated steel support structure. Pupitre en aluminium peint en époxy, avec bases en aluminium poli montées sur des roulettes avec frein et structure portante en acier chromé. Atril de aluminio pintado con polvos epoxi, con bases de aluminio brillante montadas sobre ruedas con freno y estructura portante de acero cromado. Rednerpult aus pulverbeschichtetem Aluminium, Untergestell aus poliertem Aluminium auf Rollen mit Bremsen und Halterung aus verchromtem Stahl.</p>	

	 <p>4 pz. 4 pcs</p> <p>1 pz. 1 pcs</p> 	  <p>1SP07/S € 148,00</p>
CD.		
PR.		
CL.	BO	T
DS.	<p>Vaschetta in acciaio verniciato con polveri epossidiche per l'alloggiamento dei cavi e 4 anelli passacavi in tecnopolimero applicabili al leggio cod. Steel tray painted with epoxy powders for housing the cables and 4 technopolymer cable rings applicable to the bookstand structure cod.: Bac en acier peint en époxy pour le logement des câbles et 4 anneaux passacâbles en technopolymère à appliquer à la structure du pupitre réf.: Bandeja de acero recubierta en epoxi para el alojamiento los cables y 4 anillos de cable de tecnopolimero aplicables a la estructura del atril código Epoxipulver beschichtetem Stahlwanne zur Aufnahme von Kabeln und 4 Technopolymer-Kabelverschraubungen für den Aufbau des Rednerpultes Code 1SP07-CBO</p>	<p>Espositore a busta in metacrilato trasparente per leggio cod. Transparent methacrylate eveloppe like display for bookstand cod. Présentoir à enveloppe en méthacrylate transparent pour pupitre réf. Pantalla a sobre de metacrilato transparente para soporte de voz cód. Methacrylat-Display für Rednerpult Art.Nr. 1SP07-CBO</p>

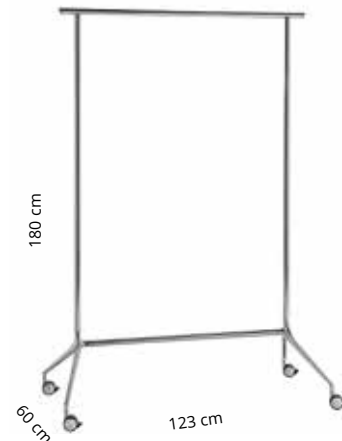

Vedi articoli disponibili
a pag. 192
See the available items
at page 192
Voir les articles
disponibles à la page 192
Ver los artículos
disponibles en la página 192
Bitte beachten Sie die verfügar-
en Produkte auf Seite 192



CD.

1SS12-C

PR.

€ 496,00

CL.

C

DS.

Stander portabili in acciaio cromato, con base in alluminio lucidato montata su ruote con freno e struttura portante in acciaio cromato.
 Chrome-plated steel free-standing coat stand, with polished aluminum base mounted on casters with stoppers and chrome-plated steel support structure.
 Portemanteau stander en acier chromé, avec base en aluminium poli montée sur des roulettes avec frein et structure portante en acier chromé.
 Percheros de acero cromado, con base de aluminio brillante montada sobre ruedas con freno y estructura portante de acero cromado.
 Kleiderständer aus verchromtem Stahl, Untergestell aus poliertem Aluminium auf Rollen mit Bremsen und Halterung aus verchromtem Stahl









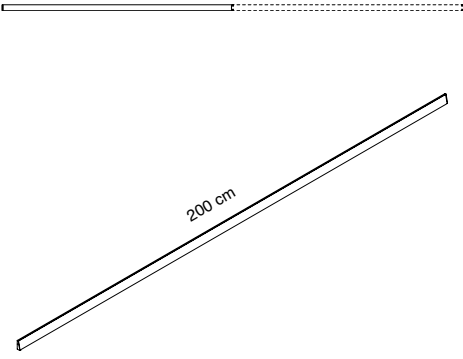
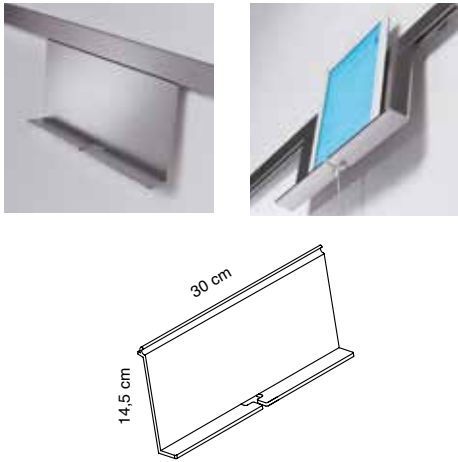
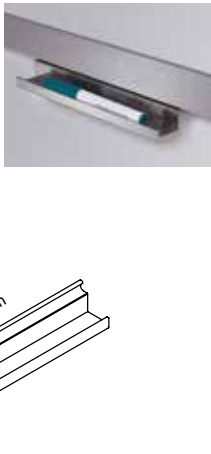
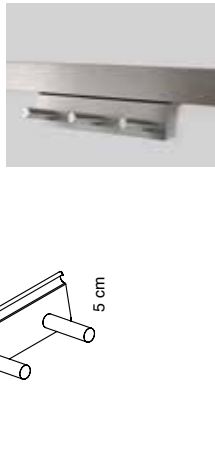
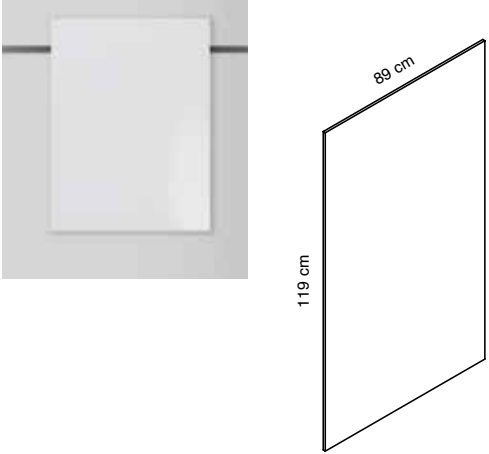
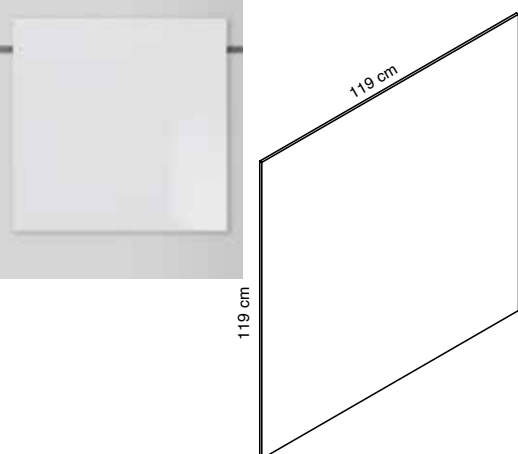
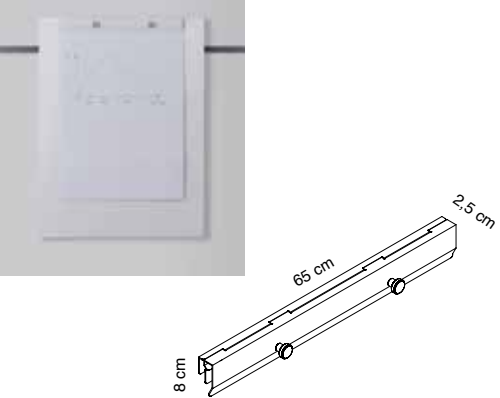

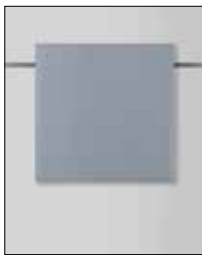

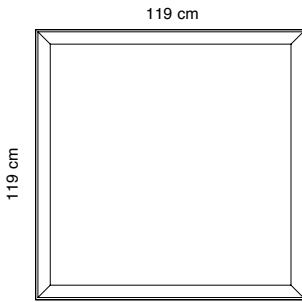









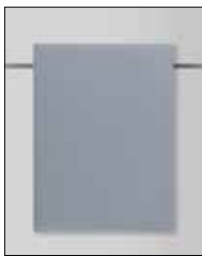

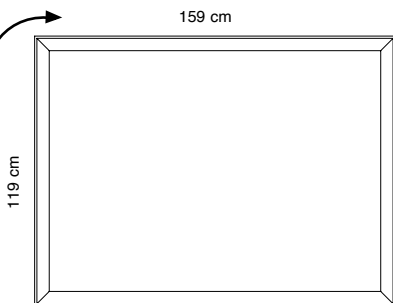
CD.

PR.

CL.

DS.

 <p>200 cm</p>	 <p>30 cm 14,5 cm</p>	 <p>20 cm 4 cm</p>	 <p>20 cm 5 cm</p>
<p>CD. 1ME200</p>	<p>CD. 1ME201</p>	<p>CD. 1ME202</p>	<p>CD. 1ME203</p>
<p>PR. € 178,00</p>	<p>PR. € 107,00</p>	<p>PR. € 38,00</p>	<p>PR. € 109,00</p>
<p>CL.</p>	<p>CL.</p>	<p>CL.</p>	<p>CL.</p>
<p>DS. Profilo modulare a parete in alluminio satinato. Modular wall profile in glazed aluminum. Profilé modulaire à fixation murale en aluminium satiné. Perfil modular de pared en aluminio satinado. Modulares Wandprofil aus satiniertem Aluminium.</p>	<p>DS. Porta tablet in alluminio satinato. Tablet support in glazed aluminum. Support tablette en aluminium satiné. Soporte para Tablet en aluminio satinado. Tablet-Ablage aus satiniertem Aluminium.</p>	<p>DS. Portaoggetti in alluminio satinato. Storage compartment in glazed aluminum. Porte-objets en aluminium satiné. Compartimento para almacenar en aluminio satinado. Ablagefach aus satiniertem Aluminium.</p>	<p>DS. Portabiti in acciaio e alluminio satinato. Clothes hanger in glazed aluminum and steel. Portemanteau en acier et aluminium satiné. Colgador de ropa en aluminio satinado y acero. Kleiderhaken aus satiniertem Aluminium und Stahl.</p>
 <p>89 cm 119 cm</p>	 <p>119 cm 119 cm</p>	 <p>8 cm 65 cm 2,5 cm</p>	
<p>CD. 1ME90</p>	<p>CD. 1ME120</p>	<p>CD. 1ME204</p>	
<p>PR. € 405,00</p>	<p>PR. € 586,00</p>	<p>PR. € 168,00</p>	
<p>CL.</p>	<p>CL.</p>	<p>CL. BO</p>	
<p>DS. Lavagna in laminato lucido colore bianco, completa di struttura posteriore in acciaio verniciato bianco e tecnopolimero, con piastra per fissaggio a profilo cod. 1ME200. Shiny laminated whiteboard, integrated with powder coated white steel and technopolymer structure with plate for fixings to wall profile code 1ME200. Tableau en laminé poli blanc, avec structure postérieure en acier peint époxy blanc et technopolymère avec platine pour la fixation au profilé réf. 1ME200. Pizarra laminada brillante, incluye estructura de respaldo de acero barnizado epoxy blanco y tecnopolimero con una pletina para fijación al perfil a pared ref. 1ME200. Glänzend laminierte Weißwandtafel, integriert mit Halterung aus weiss pulver beschichtetem Stahl aus Technopolymer zur Befestigung am Wandprofil Art. Nr. 1ME200.</p>	<p>DS. Supporto asportabile in acciaio verniciato con dettagli in alluminio per blocchi carta (non inclusi). Removable support in powder coated steel with aluminium details for notebooks (not included). Supporto amovibile en acier peint avec détails en aluminium pour bloc-papier (pas inclus). Acero pintado soporte extraíble con detalles de aluminio para blocs de papel (no incluidas). Abnehmbarer Halter aus beschichtetem Stahl mit Aluminiumdetails für Papierblock (nicht enthalten).</p>		

		 <p>SOUND ABSORBING PANELS</p> <p>Assorbimento acustico: vedi grafico pag 133 Sound absorption: see graph p. 133 Absorption acoustique: voir graphique p. 133 Absorción acústica: ver gráfico p. 133 Schallabsorption: siehe Grafik S. 133</p>					
CD.	1ME1212-0001	1ME1212-8004	1ME1212-8007	1ME1212-1008	1ME1212-4030	1ME1212-4027	1ME1212-7004
PR.	€ 758,00	€ 758,00	€ 758,00	€ 758,00	€ 758,00	€ 758,00	€ 758,00
CL.							
							
DS.	<p>Pannelli con imbottitura interna in poliestere a densità variabile Snowsound Technology. Rivestimento esterno in tessuto di poliestere Trevira CS. Completati di struttura posteriore in acciaio zincato e tecnopolimero, con piastra per fissaggio a profilo cod. 1ME200</p> <p>Panel with polyester internal padding with Snowsound Technology variable density. Polyester covering in Trevira CS fabric. Complete with galvanized steel and technopolymer structure with plate for fixings to wall profile code 1ME200</p> <p>Panneau avec rembourrage interne en polyester à densité variable Snowsound Technology. Revêtement externe en tissu de polyester Trevira CS. Avec structure postérieure en acier zingué et technopolymère avec platine pour la fixation au profilé réf. 1ME200</p> <p>Panel con acolchado interior de poliéster de densidad variable Snowsound Technology. Revestimiento exterior en tejido de poliéster Trevira CS. Completo con estructura de respaldo de acero galvanizado y tecnopolimero con una pletina para fijación al perfil a pared ref. 1ME200</p> <p>Paneel mit Polyester Füllung und Snowsound Technologie mit variabler Dichte. Polyester-Stoffbezug aus Trevira CS. Inklusive Halterung aus galvanisiertem Stahl aus Technopolymer zur Befestigung am Wandprofil Art. Nr. 1ME200</p>						
		 <p>SOUND ABSORBING PANELS</p> <p>Assorbimento acustico: vedi grafico pag 133 Sound absorption: see graph p. 133 Absorption acoustique: voir graphique p. 133 Absorción acústica: ver gráfico p. 133 Schallabsorption: siehe Grafik S. 133</p>					
CD.	1ME1216-0001	1ME1216-8004	1ME1216-8007	1ME1216-1008	1ME1216-4030	1ME1216-4027	1ME1216-7004
PR.	€ 848,00	€ 848,00	€ 848,00	€ 848,00	€ 848,00	€ 848,00	€ 848,00
CL.							
							
DS.	<p>Pannelli con imbottitura interna in poliestere a densità variabile Snowsound Technology. Rivestimento esterno in tessuto di poliestere Trevira CS. Completati di struttura posteriore in acciaio zincato e tecnopolimero, con piastra per fissaggio a profilo cod. 1ME200.</p> <p>Panel with polyester internal padding with Snowsound Technology variable density. Polyester covering in Trevira CS fabric. Complete with galvanized steel and technopolymer structure with plate for fixings to wall profile code 1ME200.</p> <p>Panneau avec rembourrage interne en polyester à densité variable Snowsound Technology. Revêtement externe en tissu de polyester Trevira CS. Avec structure postérieure en acier zingué et technopolymère avec platine pour la fixation au profilé réf. 1ME200.</p> <p>Panel con acolchado interior de poliéster de densidad variable Snowsound Technology. Revestimiento exterior en tejido de poliéster Trevira CS. Completo con estructura de respaldo de acero galvanizado y tecnopolimero con una pletina para fijación al perfil a pared ref. 1ME200.</p> <p>Paneel mit Polyester Füllung und Snowsound Technologie mit variabler Dichte. Polyester-Stoffbezug aus Trevira CS. Inklusive Halterung aus galvanisiertem Stahl aus Technopolymer zur Befestigung am Wandprofil Art. Nr. 1ME200.</p>						

RECYCLING

design

Sezgin Aksu

Caimi Lab

Silvia Suardi

I_La raccolta differenziata è un'azione fondamentale per la sostenibilità ambientale e sociale, poiché promuove un utilizzo responsabile delle risorse naturali. Le nostre soluzioni per la raccolta differenziata sono pensate per integrarsi armoniosamente in diversi ambienti unendo design, praticità e cura dei dettagli, rendendo semplice e gratificante la partecipazione a questo gesto ecologico.

E_Separate waste collection is at the heart of environmental and social sustainability as it promotes the responsible use of natural resources. Our recycling solutions deliberately blend harmoniously into a variety of environments by combining design, practicality and attention to detail, making it easy and rewarding to be part of a greener world.

F_La collecte sélective est une action fondamentale pour la durabilité environnementale et sociale, puisqu'elle favorise l'utilisation responsable des ressources naturelles. Nos solutions pour le tri des déchets sont conçues pour s'intégrer harmonieusement dans différents milieux en combinant design, praticité et attention aux détails, ce qui fait de ce geste écologique une action simple et gratifiante.

E_La recogida selectiva de residuos fomenta un uso responsable de los recursos naturales, por lo que resulta esencial para alcanzar la sostenibilidad, tanto medioambiental como social. Nuestras soluciones para la recogida selectiva de residuos están proyectadas para integrarse de manera armoniosa en entornos diversos, conciliando el diseño, el sentido práctico y la atención al detalle, y consiguiendo que participar en este gesto ecológico resulte sencillo y gratificante.

D_Mülltrennung ist ein grundlegendes Element für die ökologische und soziale Nachhaltigkeit, indem sie einen verantwortungsvollen Umgang mit den natürlichen Ressourcen fördert. Unsere Lösungen für die Mülltrennung sind so konzipiert, dass sie sich harmonisch in verschiedene Räumlichkeiten einfügen, indem sie Design, Zweckmäßigkeit und Liebe zum Detail miteinander verbinden. Die Mülltrennung ist somit ein einfacher und lohnender Weg in eine Grünere Umwelt.

MAXI

70 L



CD.	360-GAGR	360-GAR	360-GAVE	360-GABL	360-GAGL
PR.	€ 198,00	€ 208,00	€ 208,00	€ 208,00	€ 208,00
CL.	GA	GA	GA	GA	GA
	Top grigio Grey top Top gris Top gris Graues Top	Top rosso Red top Top rouge Top rojo Rotes Top	Top verde Green top Top vert Top verde Grünes Top	Top blu Blue top Top bleu Top azul Blaues Top	Top giallo Yellow top Top jaune Top amarillo Gelbes Top

DS. Cestino per la raccolta differenziata in acciaio verniciato. Top in tecnopolimero.
Bin for waste separation, made in powder-coated steel. High-tech polymer top.
Corbeille en acier peint pour le tri sélectif des déchets. Top en technopolymère.
Papelerera en acero pintado para la recogida selectiva. Top en tecnopolimero.
Abfallbehälter zur Mülltrennung, aus pulverbeschichtetem Stahl. Aufsatz aus Technopolymer.

MAXI

85 L



CD.	365-GAGR	365-GAR	365-GAVE	365-GABL	365-GAGL
PR.	€ 208,00	€ 218,00	€ 218,00	€ 218,00	€ 218,00
CL.	GA	GA	GA	GA	GA
	Top grigio Grey top Top gris Top gris Graues Top	Top rosso Red top Top rouge Top rojo Rotes Top	Top verde Green top Top vert Top verde Grünes Top	Top blu Blue top Top bleu Top azul Blaues Top	Top giallo Yellow top Top jaune Top amarillo Gelbes Top

DS. Cestino per la raccolta differenziata in acciaio verniciato. Top in tecnopolimero.
Bin for waste separation, made in powder-coated steel. High-tech polymer top.
Corbeille en acier peint pour le tri sélectif des déchets. Top en technopolymère.
Papelerera en acero pintado para la recogida selectiva. Top en tecnopolimero.
Abfallbehälter zur Mülltrennung, aus pulverbeschichtetem Stahl. Aufsatz aus Technopolymer.

MAXI					70 L
CD.	360-BOBO	360-BOR	360-BOVE	360-BOBL	360-BOGL
PR.	€ 198,00	€ 208,00	€ 208,00	€ 208,00	€ 208,00
CL.	BO	BO	BO	BO	BO
	Top bianco White top Top blanc Top blanco Weiss Top	Top rosso Red top Top rouge Top rojo Rotes Top	Top verde Green top Top vert Top verde Grünes Top	Top blu Blue top Top bleu Top azul Blaues Top	Top giallo Yellow top Top jaune Top amarillo Gelbes Top
DS.	<p>Cestino per la raccolta differenziata in acciaio verniciato. Top in tecnopolimero. Bin for waste separation, made in powder-coated steel. High-tech polymer top. Corbeille en acier peint pour le tri sélectif des déchets. Top en technopolymère. Papelera en acero pintado para la recogida selectiva. Top en tecnopolimero. Abfallbehälter zur Mülltrennung, aus pulverbeschichtetem Stahl. Aufsatz aus Technopolymer.</p>				
MAXI					85 L
CD.	365-BOBO	365-BOR	365-BOVE	365-BOBL	365-BOGL
PR.	€ 208,00	€ 218,00	€ 218,00	€ 218,00	€ 218,00
CL.	BO	BO	BO	BO	BO
	Top bianco White top Top blanc Top blanco Weiss Top	Top rosso Red top Top rouge Top rojo Rotes Top	Top verde Green top Top vert Top verde Grünes Top	Top blu Blue top Top bleu Top azul Blaues Top	Top giallo Yellow top Top jaune Top amarillo Gelbes Top
DS.	<p>Cestino per la raccolta differenziata in acciaio verniciato. Top in tecnopolimero. Bin for waste separation, made in powder-coated steel. High-tech polymer top. Corbeille en acier peint pour le tri sélectif des déchets. Top en technopolymère. Papelera en acero pintado para la recogida selectiva. Top en tecnopolimero. Abfallbehälter zur Mülltrennung, aus pulverbeschichtetem Stahl. Aufsatz aus Technopolymer.</p>				

MAXI

50 L



CD.	363-BOBO	363-BOR	363-BOVE	363-BOBL	363-BOGL
PR.	€ 168,00	€ 178,00	€ 178,00	€ 178,00	€ 178,00
CL.	BO	BO	BO	BO	BO
	Top bianco White top Top blanc Top blanco Weiss Top	Top rosso Red top Top rouge Top rojo Rotes Top	Top verde Green top Top vert Top verde Grünes Top	Top blu Blue top Top bleu Top azul Blaues Top	Top giallo Yellow top Top jaune Top amarillo Gelbes Top

DS. Cestino per la raccolta differenziata in acciaio verniciato. Top in tecnopolimero.
 Bin for waste separation, made in powder-coated steel. High-tech polymer top.
 Corbeille en acier peint pour le tri sélectif des déchets. Top en technopolymère.
 Papelera en acero pintado para la recogida selectiva. Top en tecnopolimero.
 Abfallbehälter zur Mülltrennung, aus pulverbeschichtetem Stahl. Aufsatz aus Technopolymer.

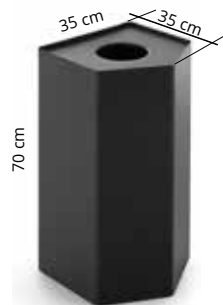

BINZ

70 L



CD.	287-N
PR.	€ 328,00
CL.	N
	Nero / Top nero Black / Black top Noir / Top noir Negro / Top negro Schwarze / Schwarzer Top

DS. Cestino per la raccolta differenziata in acciaio verniciato. Coperchio ribaltabile in acciaio verniciato.
 Bin for waste separation, made in powder-coated steel. Powder-coated steel hinged top.
 Corbeille en acier peint pour le tri sélectif des déchets. Couvercle rebattable en acier peint.
 Papelera en acero pintado para la recogida selectiva. Tapa basculante en acero pintado.
 Abfallbehälter zur Mülltrennung, aus pulverbeschichtetem Stahl. Klappdeckel aus pulverbeschichtetem Stahl.

<p>MAXIMO MODULAR</p>  <p>24 cm 35 cm 72 cm</p> <p>60 L</p> <p>469-GY</p>	 <p>24 cm 35 cm 72 cm</p> <p>60 L</p> <p>469-VO</p>
<p>CD.</p>	<p>PR.</p>
<p>CL.</p>	<p>€ 248,00</p>
<p>GY (RAL 7043)</p> <p>Grigio city RAL 7043 Dark grey RAL 7043 Gris foncé RAL 7043 Gris oscuro RAL 7043 Dunkelgrau RAL 7043</p>	<p>VO (RAL 6013)</p> <p>Verde oliva RAL 6013 Green RAL 6013 Vert RAL 6013 Verde RAL 6013 Grün RAL 6013</p>
<p>DS.</p> <p>Cestino modulare per la raccolta differenziata interamente realizzato in acciaio verniciato con polveri epossidiche, dotato di coperchi ribaltabili e reggisacchetto asportabile. Modular bin/trash can designed for separate waste collection made entirely of epoxy-coated steel, with hinged lids and a removable inner bucket. Corbeille modulaire conçue pour le tri sélectif des déchets, réalisée entièrement en acier verni avec poudres époxy, munie de couvercles rabattables et d'un porte-sacchet amovible. Papelera modular concebido para la recogida selectiva completamente de acero pintado con polvos epoxi, equipado con tapa basculante y soporte para bolsa extraíble. Modularer idealer Behälter für Mülltrennung, gänzlich aus epoxidstaublackiertem Stahl hergestellt, mit Klappdeckel und abnehmbarem Sackhalter.</p>	

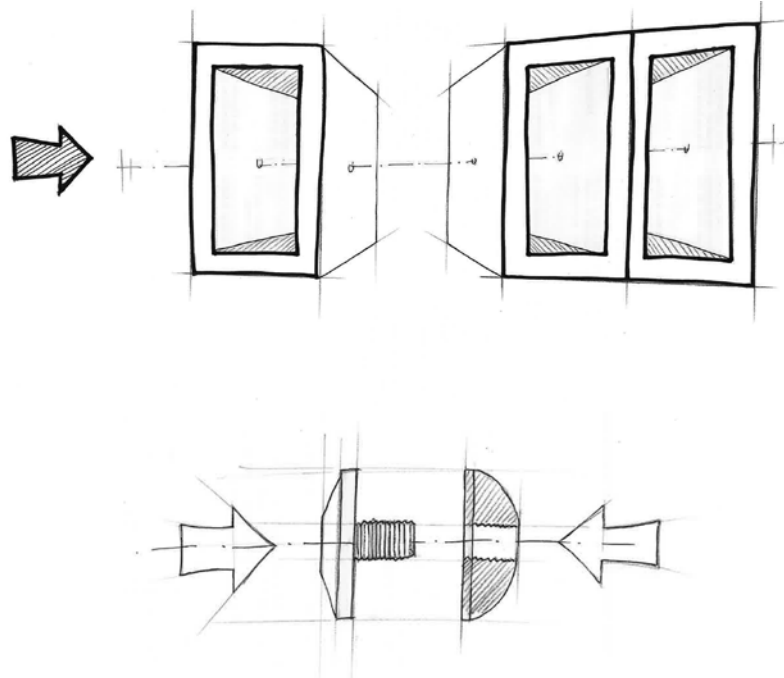

CENTOLITRI

100 L



CD.	280-GAGR	280-GAR	280-GAVE	280-GABL	280-GAGL
PR.	€ 358,00	€ 358,00	€ 358,00	€ 358,00	€ 358,00
CL.	GA	GA	GA	GA	GA
	Top grigio Grey top Top gris Top gris Graues Top	Top rosso Red top Top rouge Top rojo Rotes Top	Top verde Green top Top vert Top verde Grünes Top	Top blu Blue top Top bleu Top azul Blaues Top	Top giallo Yellow top Top jaune Top amarillo Gelbes Top

DS. Cestino per la raccolta differenziata in acciaio verniciato. Top in acciaio verniciato.
Bin for waste separation, made in powder-coated steel. Powder-coated steel top.
Corbeille en acier peint pour le tri sélectif des déchets. Top en acier peint.
Papelera en acero pintado para la recogida selectiva. Top en acero pintado.
Abfallbehälter zur Mülltrennung, aus pulverbeschichtetem Stahl. Aufsatz aus pulverbeschichtetem Stahl.

CENTOLITRI

100 L



CD.	280-BOBO	280-BOR	280-BOVE	280-BOBL	280-BOGL
PR.	€ 358,00	€ 358,00	€ 358,00	€ 358,00	€ 358,00
CL.	BO	BO	BO	BO	BO
	Top bianco White top Top blanc Top blanco Weiss Top	Top rosso Red top Top rouge Top rojo Rotes Top	Top verde Green top Top vert Top verde Grünes Top	Top blu Blue top Top bleu Top azul Blaues Top	Top giallo Yellow top Top jaune Top amarillo Gelbes Top

DS. Cestino per la raccolta differenziata in acciaio verniciato. Top in acciaio verniciato.
Bin for waste separation, made in powder-coated steel. Powder-coated steel top.
Corbeille en acier peint pour le tri sélectif des déchets. Top en acier peint.
Papelera en acero pintado para la recogida selectiva. Top en acero pintado.
Abfallbehälter zur Mülltrennung, aus pulverbeschichtetem Stahl. Aufsatz aus pulverbeschichtetem Stahl.

CENTOLITRI

100 L



CD.	280-NN	280-NR	280-NVE	280-NBL	280-NGL
PR.	€ 358,00	€ 358,00	€ 358,00	€ 358,00	€ 358,00
CL.	N	N	N	N	N
	Top nero Black top Top noir Top negro Schwarzes Top	Top rosso Red top Top rouge Top rojo Rotes Top	Top verde Green top Top vert Top verde Grünes Top	Top blu Blue top Top bleu Top azul Blauzes Top	Top giallo Yellow top Top jaune Top amarillo Gelbes Top

DS. Cestino per la raccolta differenziata in acciaio verniciato. Top in acciaio verniciato.
Bin for waste separation, made in powder-coated steel. Powder-coated steel top.
Corbeille en acier peint pour le tri sélectif des déchets. Top en acier peint.
Papelera en acero pintado para la recogida selectiva. Top en acero pintado.
Abfallbehälter zur Mülltrennung, aus pulverbeschichtetem Stahl. Aufsatz aus pulverbeschichtetem Stahl.

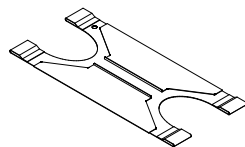
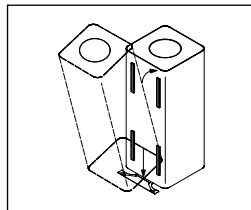

CD.	282-GA
PR.	€ 49,50
CL.	GA
	

DS. Piastra e magneti per unione lineare cestoni Centolitre. **Opzionale. Per art. 280-XX e 285-XX**
Plate and magnets for linear union baskets Centolitre. **Optional. For codes 280-XX and 285-XX**
Plaque et aimants pour l'assemblage linéaire des paniers Centolitre. **Optionnel. Pour art. 280-XX et 285-XX**
Placa e imanes para la unión lineal de cestas Centolitre. **Opcional. Para art. 280-XX y 285-XX**
Platte und Magnete für die lineare Verbindung von Körben Centolitre. **Optional. Für Art. 280-XX und 285-XX**



CENTOLITRI

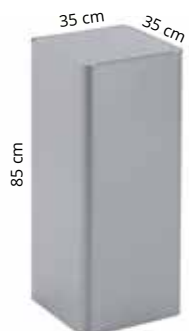

100 L



CD.	285-GA	285-BO	285-N
PR.	€ 358,00	€ 358,00	€ 358,00
CL.	GA	BO	N
DS.	Grigio / Top grigio Grey / Grey top Gris / Top gris Gris / Top gris Graue / Graues Top	Bianco / Top bianco White / White top Blanc / Top blanc Blanco / Top blanco Weiss / Weisser Top	Nero / Top nero Black / Black top Noir / Top noir Negro / Top negro Schwarze / Schwarzer Top
<p>Cestino per la raccolta differenziata in acciaio verniciato. Top in acciaio verniciato. Bin for waste separation, made in powder-coated steel. Powder-coated steel top. Corbeille en acier peint pour le tri sélectif des déchets. Top en acier peint. Papelera en acero pintado para la recogida selectiva. Top en acero pintado. Abfallbehälter zur Mülltrennung, aus pulverbeschichtetem Stahl. Aufsatz aus pulverbeschichtetem Stahl.</p>			

CENTOLITRI LOCK











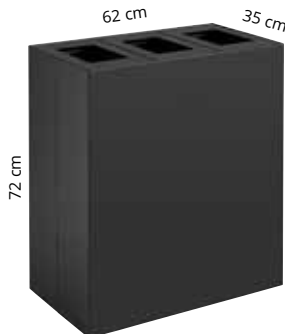



Con serratura
With lock
Avec serrure
Con cerradura
Mit Schloss



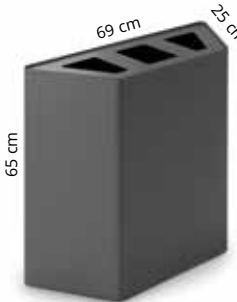
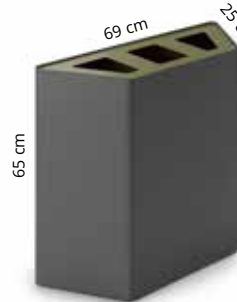
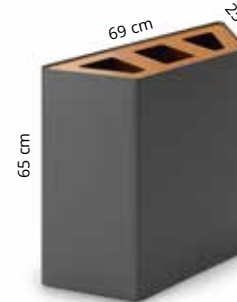

100 L

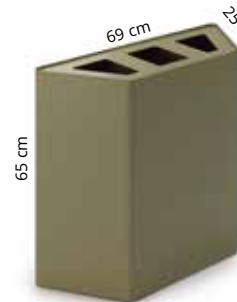
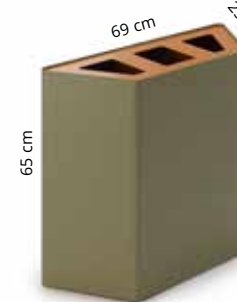

CD.	283-NN	283-NR	283-NVE	283-NBL	283-NGL
PR.	€ 419,00	€ 419,00	€ 419,00	€ 419,00	€ 419,00
CL.	N	N	N	N	N
DS.	Top nero Black top Top noir Top negro Schwarzes Top	Top rosso Red top Top rouge Top rojo Rotes Top	Top verde Green top Top vert Top verde Grünes Top	Top blu Blue top Top bleu Top azul Blaues Top	Top giallo Yellow top Top jaune Top amarillo Gelbes Top
<p>Cestino per la raccolta differenziata in acciaio verniciato. Top in acciaio verniciato. Apertura frontale. Bin for waste separation, made in powder-coated steel. Powder-coated steel top. Frontal opening. Corbeille en acier peint pour le tri sélectif des déchets. Top en acier peint. Ouverture frontale. Papelera en acero pintado para la recogida selectiva. Top en acero pintado. Apertura frontal. Abfallbehälter zur Mülltrennung, aus pulverbeschichtetem Stahl. Aufsatz aus pulverbeschichtetem Stahl. Vordere Öffnung.</p>					

	<p>MAXIMO</p>  <p>62 cm 35 cm 72 cm</p> <p>468-N</p>	  <p>62 cm 35 cm 72 cm</p> <p>468-BO</p>	<p>3 x 50 L = 150 L</p> 
CD.	<p>€ 580,00</p>		<p>€ 580,00</p>
CL.	<p>N</p>		<p>BO</p>
	<p>Nero / Top nero Black / Black top Noir / Top noir Negro / Top negro Schwarze / Schwarzer Top</p>		<p>Bianco / Top bianco White / White top Blanc / Top blanc Blanco / Top blanco Weiss / Weisser Top</p>
DS.	<p>Cestino per la raccolta differenziata interamente realizzato in acciaio verniciato con polveri epossidiche, dotato di coperchi ribaltabili e reggisacchetto asportabile. A bin/trash can designed for separate waste collection made entirely of epoxy-coated steel, with hinged lids and a removable inner bucket. Corbeille conçue pour le tri sélectif des déchets, réalisée entièrement en acier verni avec poudres époxy, munie de couvercles rabattables et d'un porte-sacchet amovible. Papelerera concebido para la recogida selectiva completamente de acero pintado con polvos epoxi, equipado con tapa basculante y soporte para bolsa extraíble. Ein idealer Behälter für Mülltrennung, gänzlich aus epoxidstaublackiertem Stahl hergestellt, mit Klappdeckel und abnehmbarem Sackhalter.</p>		
	<p>MAXIMO LOCK</p>  	 <p>62 cm 35 cm 72 cm</p> <p>468/S-BO</p>	<p>3 x 50 L = 150 L</p> 
CD.	<p>€ 595,00</p>		<p>€ 595,00</p>
PR.			
CL.	<p>BO</p>		<p>BO</p>
	<p>Bianco / Top bianco White / White top Blanc / Top blanc Blanco / Top blanco Weiss / Weisser Top</p>		<p>Con serratura With lock Avec serrure Con cerradura Mit Schloss</p> 
DS.	<p>Cestino per la raccolta differenziata interamente realizzato in acciaio verniciato con polveri epossidiche, dotato di coperchi ribaltabili e reggisacchetto asportabile. A bin/trash can designed for separate waste collection made entirely of epoxy-coated steel, with hinged lids and a removable inner bucket. Corbeille conçue pour le tri sélectif des déchets, réalisée entièrement en acier verni avec poudres époxy, munie de couvercles rabattables et d'un porte-sacchet amovible. Papelerera concebido para la recogida selectiva completamente de acero pintado con polvos epoxi, equipado con tapa basculante y soporte para bolsa extraíble. Ein idealer Behälter für Mülltrennung, gänzlich aus epoxidstaublackiertem Stahl hergestellt, mit Klappdeckel und abnehmbarem Sackhalter.</p>		

LINEAR				3 x 30 L = 90 L	
					
CD.	460-GYGY	460-GYVO	460-GYGO		
PR.	€ 495,00	€ 495,00	€ 495,00		
CL.	GY (RAL 7043)	GY (RAL 7043)	GY (RAL 7043)		
DS.	<p>Top grigio city RAL 7043 Dark grey top RAL 7043 Top gris foncé RAL 7043 Top gris oscuro RAL 7043 Dunkelgrau Top RAL 7043</p> 	<p>Top verde oliva RAL 6013 Green top RAL 6013 Top vert RAL 6013 Top verde RAL 6013 Grünes Top RAL 6013</p> 	<p>Top giallo ocra RAL 8001 Yellow top RAL 8001 Top jaune RAL 8001 Top amarillo RAL 8001 Gelbes Top RAL 8001</p> 	<p>Cestino per la raccolta differenziata interamente realizzato in acciaio verniciato con polveri epossidiche, dotato di reggisacchetti asportabile. A bin/trash can designed for separate waste collection made entirely of epoxy-coated steel, with removable inner buckets. Corbeille conçue pour le tri sélectif des déchets, réalisée entièrement en acier verni avec poudres époxy, munie de porte-sachets amovible. Papeleria concebido para la recogida selectiva completamente de acero pintado con polvos epoxi, equipado con soportes para bolsa extraíble. Ein idealer Behälter für Mülltrennung, gänzlich aus epoxidstaublackiertem Stahl hergestellt, mit abnehmbarem Sackhalter.</p>	

LINEAR				3 x 30 L = 90 L	
					
CD.	460-VOGY	460-VOVO	460-VOGO		
PR.	€ 495,00	€ 495,00	€ 495,00		
CL.	VO (RAL 6013)	VO (RAL 6013)	VO (RAL 6013)		
DS.	<p>Top grigio city RAL 7043 Dark grey top RAL 7043 Top gris foncé RAL 7043 Top gris oscuro RAL 7043 Dunkelgrau Top RAL 7043</p> 	<p>Top verde oliva RAL 6013 Green top RAL 6013 Top vert RAL 6013 Top verde RAL 6013 Grünes Top RAL 6013</p> 	<p>Top giallo ocra RAL 8001 Yellow top RAL 8001 Top jaune RAL 8001 Top amarillo RAL 8001 Gelbes Top RAL 8001</p> 	<p>Cestino per la raccolta differenziata interamente realizzato in acciaio verniciato con polveri epossidiche, dotato di reggisacchetti asportabile. A bin/trash can designed for separate waste collection made entirely of epoxy-coated steel, with removable inner buckets. Corbeille conçue pour le tri sélectif des déchets, réalisée entièrement en acier verni avec poudres époxy, munie de porte-sachets amovible. Papeleria concebido para la recogida selectiva completamente de acero pintado con polvos epoxi, equipado con soportes para bolsa extraíble. Ein idealer Behälter für Mülltrennung, gänzlich aus epoxidstaublackiertem Stahl hergestellt, mit abnehmbarem Sackhalter.</p>	

LINEAR

3 x 30 L = 90 L

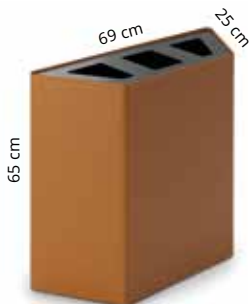

460-GOGY

€ 495,00

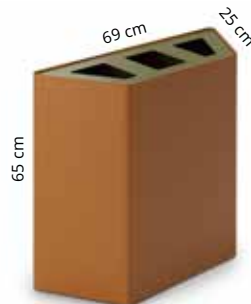

460-GOVO

€ 495,00

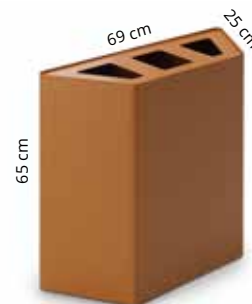

460-GOGO

€ 495,00

CD.

PR.

CL.

GO (RAL 8001)

GO (RAL 8001)

GO (RAL 8001)

Top grigio city RAL 7043
Dark grey top RAL 7043
Top gris foncé RAL 7043
Top gris oscuro RAL 7043
Dunkelgrau Top RAL 7043



Top verde oliva RAL 6013
Green top RAL 6013
Top vert RAL 6013
Top verde RAL 6013
Grünes Top RAL 6013





Top giallo ocra RAL 8001
Yellow top RAL 8001
Top jaune RAL 8001
Top amarillo RAL 8001
Gelbes Top RAL 8001



DS.

Cestino per la raccolta differenziata interamente realizzato in acciaio verniciato con polveri epossidiche, dotato di reggisacchetti asportabile.
A bin/trash can designed for separate waste collection made entirely of epoxy-coated steel, with removable inner buckets.
Corbeille conçue pour le tri sélectif des déchets, réalisée entièrement en acier verni avec poudres époxy, munie de porte-sachets amovible.
Papeleria concebido para la recogida selectiva completamente de acero pintado con polvos epoxi, equipado con soportes para bolsa extraible.
Ein idealer Behälter für Mülltrennung, gänzlich aus epoxidstaublackiertem Stahl hergestellt, mit abnehmbarem Sackhalter.

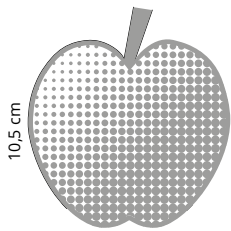
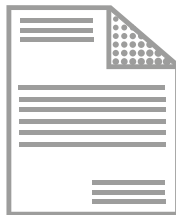
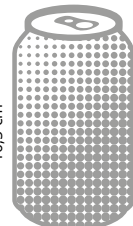
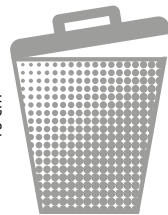
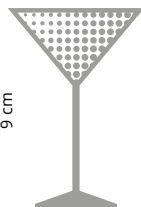







	 10,5 cm 9,5 cm	 9,5 cm 8 cm	 10,5 cm 6 cm	 10 cm 8 cm	 9 cm 7 cm	 10,5 cm 3,5 cm
CD.	324	325	326	327	328	329
PR.	€ 17,80	€ 17,80	€ 17,80	€ 17,80	€ 17,80	€ 17,80
CL.						

Utilizzabili per articoli: **MAXI - MAXIMO - CENTOLITRI - BINZ - LINEAR - PRISMA**
 Usable for items: **MAXI - MAXIMO - CENTOLITRI - BINZ - LINEAR - PRISMA**
 A utiliser pour les réf **MAXI - MAXIMO - CENTOLITRI - BINZ - LINEAR - PRISMA**
 Para **MAXI - MAXIMO - CENTOLITRI - BINZ - LINEAR - PRISMA**
 S Verwendung mit Art. **MAXI - MAXIMO - CENTOLITRI - BINZ - LINEAR - PRISMA**



DS. Grafiche adesive in tecnopolimero.
 Adhesive graphics in technopolymer.
 Graphiques autocollantes en technopolymère.
 Gráficas adhesivas de tecnopolímero.
 Kleber aus technischem Kunststoff mit Grafiken.

	 ~ 5 cm ~ 4,5 cm			
				
CD.	330			
PR.	€ 39,00			
CL.				

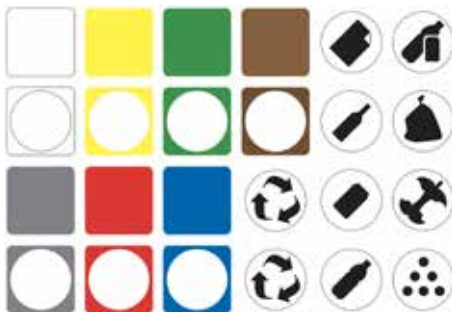
	 5,5 cm 5,5 cm
CD.	80326
PR.	€ 52,00
CL.	

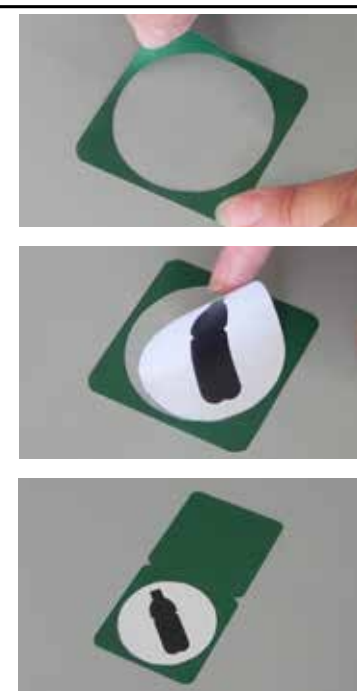

DS. Utilizzabili per articoli: **MAXI - MAXIMO - CENTOLITRI - BINZ - LINEAR - PRISMA**
 Usable for items: **MAXI - MAXIMO - CENTOLITRI - BINZ - LINEAR - PRISMA**
 A utiliser pour les réf **MAXI - MAXIMO - CENTOLITRI - BINZ - LINEAR - PRISMA**
 Para **MAXI - MAXIMO - CENTOLITRI - BINZ - LINEAR - PRISMA**
 S Verwendung mit Art. **MAXI - MAXIMO - CENTOLITRI - BINZ - LINEAR - PRISMA**

Grafiche adesive in tecnopolimero.
 Adhesive graphics in technopolymer.
 Graphiques autocollantes en technopolymère.
 Gráficas adhesivas de tecnopolímero.
 Kleber aus technischem Kunststoff mit Grafiken.

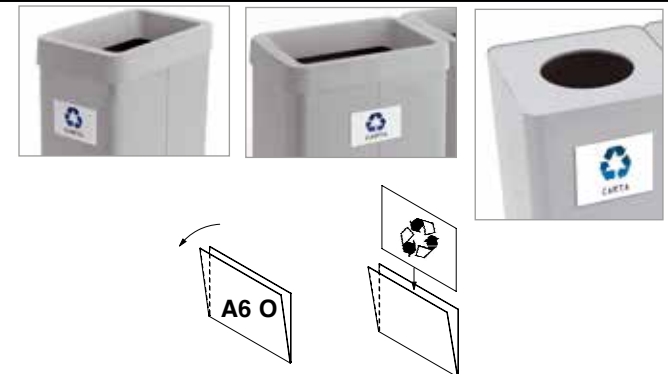

Kit 24 etichette combinabili fra di loro.
 Kit of 24 combinable labels.
 Jeu de 24 étiquettes combinables.
 Set von 24 kombinierbaren Etiketten.

		
CD.	379	236
PR.	€ 17,50	€ 39,50
CL.		T
	<p>6 etichette per simbolo (6x9 = tot. 54). Per articoli: MAXI - MAXIMO - CENTOLITRI - BINZ - LINEAR - PRISMA 6 labels per symbol (6x9 = tot. 54). For items: MAXI - MAXIMO - CENTOLITRI - BINZ - LINEAR - PRISMA 6 étiquettes par symbole (6x9 = tot. 54). Pour les réf MAXI - MAXIMO - CENTOLITRI - BINZ - LINEAR - PRISMA 6 etiquetas para simbolo (6x9 = tot. 54). Para MAXI - MAXIMO - CENTOLITRI - BINZ - LINEAR - PRISMA 6 Etiketten pro Symbolen (6x9 = insg. 54). Für Art. MAXI - MAXIMO - CENTOLITRI - BINZ - LINEAR - PRISMA</p>	<p>Utilizzabili per articoli: MAXI - MAXIMO - CENTOLITRI - BINZ - PRISMA Usable for items: MAXI - MAXIMO - CENTOLITRI - BINZ - PRISMA A utiliser pour les réf MAXI - MAXIMO - CENTOLITRI - BINZ - PRISMA Para MAXI - MAXIMO - CENTOLITRI - BINZ - PRISMA S Verwendung mit Art. MAXI - MAXIMO - CENTOLITRI - BINZ - PRISMA</p>
DS.	<p>Foglio di etichette con simboli per la raccolta differenziata. Label sheet with symbols for waste separation. Feuille d'étiquettes avec symboles pour le tri sélectif des déchets. Hoja de etiquetas con símbolos para la recogida selectiva. Etiketten mit Symbolen für Mülltrennung.</p>	<p>Espositore a busta in metacrilato trasparente applicabile ai contenitori tramite biadesivo. Envelope display unit for bins, in transparent methacrylate with double-sided tape. Présentoir en méthacrylate transparent et biadhésif pour corbeilles. Expositor en metacrilato transparente con puertas aplicable al contenedor con bi-adesivo. Beschriftungsschild für Abfallbehälter, aus transparentem Kunststoff, + doppelseitigem Klebeband.</p>



**Personalizzazione.
 Customization.
 Personnalisation.
 Personalización.
 Anpassung.**

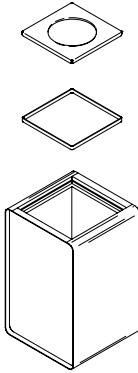

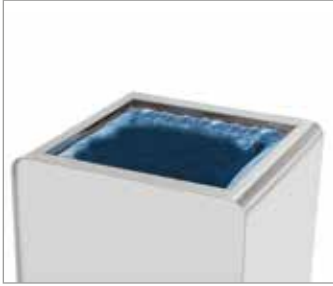
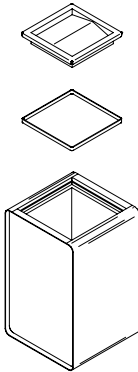
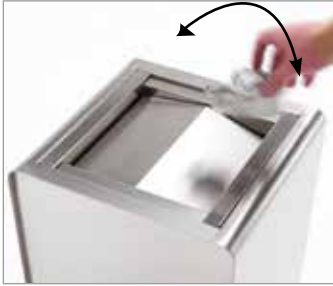
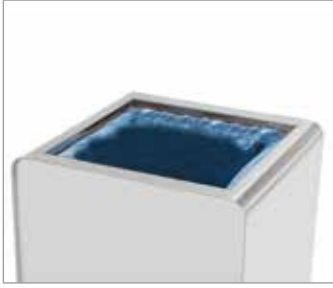
PRISMA		80 L	57 L	40 L		
CD.	217-I	217-IO	215-I	215-IO	213-I	
PR.	€ 488,00	€ 588,00	€ 478,00	€ 578,00	€ 418,00	
CL.						
	Indoor (Inox AISI 430)	Outdoor (Inox AISI 304)	Indoor (Inox AISI 430)	Outdoor (Inox AISI 304)	Indoor (Inox AISI 430)	
DS.	<p>Cestino gettacarte in acciaio inox. Stainless steel waste paper bin. Corbeille à papier en acier inox. Papelerera en acero inoxidable. Papierkorb aus rostfreiem Stahl.</p>					  
CD.	227-I	227-IO	225-I	225-IO	223-I	
PR.	€ 530,00	€ 630,00	€ 520,00	€ 620,00	€ 460,00	
CL.						
	Indoor (Inox AISI 430)	Outdoor (Inox AISI 304)	Indoor (Inox AISI 430)	Outdoor (Inox AISI 304)	Indoor (Inox AISI 430)	
DS.	<p>Cestino gettacarte in acciaio inox con coperchio basculante a perno centrale. Stainless steel waste paper bin with central-pin up-and-over. Corbeille à papier en acier inox avec couvercle basculant à pivot central. Papelerera en acero inoxidable con oscilante de perno central. Papierkorb aus rostfreiem Stahl mit Schwingdeckel.</p>					<p>Coperchio basculante Up-and-over top Couvercle basculant Top oscillante Schwingdeckel</p>   

PRISMA



265-I

€ 530,00



265-IO

€ 630,00

CD.

PR.

CL.

Indoor (Inox AISI 430)

Outdoor (Inox AISI 304)



DS.

Portaombrelli in acciaio inox con vaschetta per ombrellini pieghevoli.
Stainless steel umbrella stand with tray for folding umbrellas.
Porte-parapluies en acier inox avec bac pour parapluies pliables.
Paragüero en acero inoxidable con cubeta para paraguas plegables.
Schirmständer aus rostfreiem Stahl mit Wanne für Knirpse.

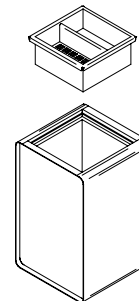

255-I

€ 488,00



255-IO

€ 588,00

CD.

PR.

CL.

Indoor (Inox AISI 430)

Outdoor (Inox AISI 304)



DS.

Portaombrelli in acciaio inox.
Stainless steel umbrella stand.
Porte-parapluies en acier inox.
Paragüero en acero inoxidable.
Schirmständer aus rostfreiem Stahl.

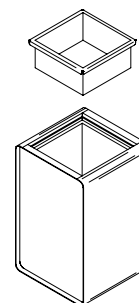

PRISMA



247-I

€ 530,00

247-IO

€ 630,00



245-I

€ 520,00

245-IO

€ 620,00

CD.

PR.

CL.

Indoor (Inox AISI 430)

Outdoor (Inox AISI 304)

Indoor (Inox AISI 430)

Outdoor (Inox AISI 304)



DS.

Posaceneri in acciaio inox.
Stainless steel ashtray.
Cendrier en acier inox.
Cenicero en acero inoxidable.
Standascher aus rostfreiem Stahl.

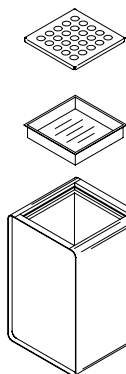

237-I

€ 530,00

237-IO

€ 630,00



235-I

€ 520,00

235-IO

€ 620,00

CD.

PR.

CL.

Indoor (Inox AISI 430)

Outdoor (Inox AISI 304)

Indoor (Inox AISI 430)

Outdoor (Inox AISI 304)



DS.

Posaceneri in acciaio inox con setaccio asportabile.
Stainless steel ashtray with removable sifter.
Cendrier en acier inox avec tamis amovible.
Cenicero en acero inoxidable con filtro extraible.
Standascher aus rostfreiem Stahl mit herausnehmbarem Sieb.

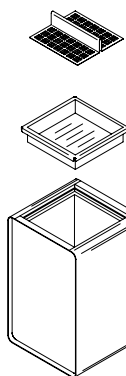

PRISMA				
CD. 277-I	277-IO	275-I	275-IO	273-I
PR. € 550,00	€ 650,00	€ 540,00	€ 640,00	€ 485,00
CL.				
Indoor (Inox AISI 430)	Outdoor (Inox AISI 304)	Indoor (Inox AISI 430)	Outdoor (Inox AISI 304)	Indoor (Inox AISI 430)
DS.	Fioriera in acciaio inox. Stainless steel flower box. Jardinière en acier inox. Maceta en acero inoxidable. Blumentöpfe aus rostfreiem Stahl.			

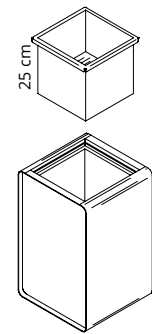

CD. 201-I	
PR. € 49,00 (4 pcs)	
CL.	
DS.	Giunti in alluminio e Velcro per unione contenitori Prisma. Aluminium and Velcro connecting joints for Prisma bins. Pièces de jonction en aluminium et Velcro pour corbeilles Prisma. Juntas en aluminio y Velcro para la union de los fustes Prisma. Verbindungsstücke aus Aluminium und Klettmaterial für Behälter Prisma.

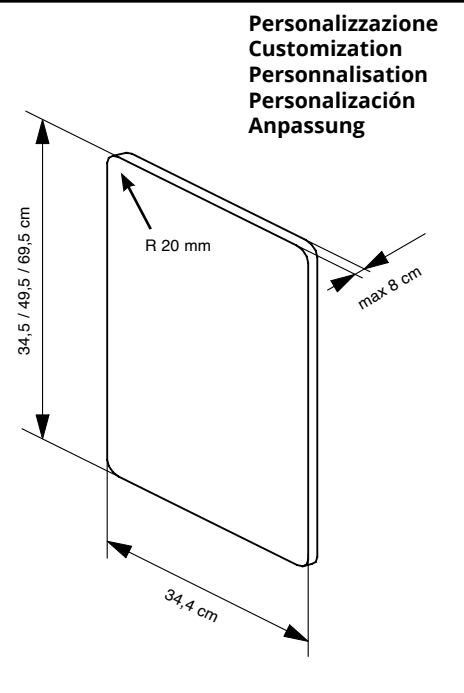

ACCESSORIES & LIGHTING

design

Acropoli

Angelotti & Cardile

Sezgin Aksu

Claudio Bellini

Claus Breinholt

Caimi Lab

Massimo Colagrande

Michele De Lucchi

Gillo Dorfles

Giulio Iacchetti

Raffaello Manzoni

Atelier Mendini

Francesca Smiraglia

Silvia Suardi

Alessandro Zambelli

ACCESSORIES

I_I nostri accessori non sono solo complementi d'arredo di alta qualità, ma veri e propri elementi che trasformano gli ambienti. Ogni pezzo è pensato per unire piacevolezza estetica, praticità e cura del dettaglio, garantendo quindi un comfort tangibile, fondamentale in tutti quegli spazi che ambiscono alla promozione del benessere dei loro occupanti.

EN_Our accessories are much more than just quality furnishings; they are transformative elements for spaces. Each piece combines aesthetic appeal, practicality and attention to detail, providing the tangible comfort essential for spaces where people's well-being is paramount.

F_Nos accessoires ne sont pas seulement des compléments d'ameublement de qualité, mais de véritables éléments qui transforment les espaces. Chaque unité est conçue pour allier plaisir esthétique, praticité et souci du détail, garantissant ainsi un confort tangible, essentiel dans tous les espaces qui visent à promouvoir le bien-être de leurs occupants.

E_Nuestros accesorios no solo son complementos de decoración de elevada calidad, sino que se trata de elementos que consiguen transformar realmente el entorno que los rodea. Cada pieza está concebida para conciliar el aspecto estético, el sentido práctico y la atención a los detalles, y para garantizar un confort tangible, esencial en aquellos espacios que aspiran a propiciar el bienestar de quien los habita.

D_Unser Zubehör umfasst nicht nur hochwertige Einrichtungsgegenstände, sondern Elemente, die Räume grundlegend verwandeln. Jedes Stück ist so konzipiert, dass es Ästhetik, Zweckmäßigkeit und Liebe zum Detail miteinander verbindet und so in allen Räumen für spürbaren Komfort und persönliches Wohlbefinden sorgt.

LIGHTING

I_Molto più che semplici fonti di luce, questi corpi illuminati portano con sé significati più profondi, legati a particolari funzioni accessorie piuttosto che originali scelte tecniche. Veri esempi di design all'avanguardia che con semplicità interpretano eleganza, personalità e comfort.

EN_More than just basic sources of illumination, these lights embody deeper meanings linked to specific accessory functions rather than mere technical choices. They are examples of cutting-edge design, interpreting elegance, personality and comfort with refreshing simplicity.

F_Plus que de simples sources de lumière, ces systèmes d'éclairage sont porteurs de significations plus profondes, liées à de particulières fonctions accessoires plutôt qu'à des choix techniques originaux. De véritables exemples de design d'avant-garde qui interprètent avec simplicité l'élégance, la personnalité et le confort.

E_Mucho más que una mera fuente de luz, estos objetos luminosos encierran significados más profundos, vinculados a funciones complementarias peculiares y a originales decisiones técnicas. Diversos ejemplos de diseños de vanguardia que interpretan con sencillez la elegancia, la personalidad y el confort.

D_Diese Leuchtkörper sind viel mehr als bloße Lichtquellen, ihre tiefere Bedeutung verdanken sie ihren einzigartigen Zusatzfunktionen und origineller technischer Auswahl. Sie sind ein Beispiel für innovatives Design, das in seiner Schlichtheit Eleganz, Persönlichkeit und Komfort vereint.

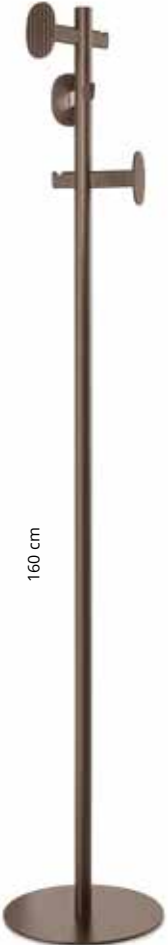
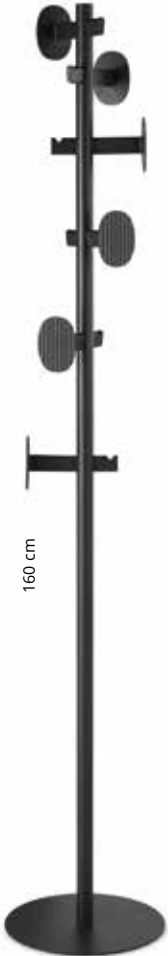
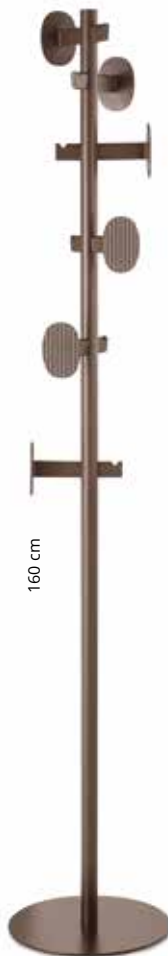
LUTHEA					
					
	160 cm	160 cm	160 cm	160 cm	
	6 ganci hooks crochets ganchos Haken	6 ganci hooks crochets ganchos Haken	12 ganci hooks crochets ganchos Haken	12 ganci hooks crochets ganchos Haken	
	ø 30 cm	ø 30 cm	ø 30 cm	ø 30 cm	
CD.	1455-N	1455-TM	1457-N	1457-TM	
PR.	€ 257,00	€ 257,00	€ 298,00	€ 298,00	
CL.	N	TM	N	TM	
	Nero opaco Matt black Noir mat Nigro mate Mattschwarz	Testa di moro Dark brown Marron foncé Marrón oscuro Dunkelbraun	Nero opaco Matt black Noir mat Nigro mate Mattschwarz	Testa di moro Dark brown Marron foncé Marrón oscuro Dunkelbraun	
DS.	<p>Portabiti a piantana interamente in metallo. Pomoli portabiti in zama, tubo centrale e base in acciaio verniciati con polveri epossidiche. Standing coat stand. Zamak hanger knobs, powder-coated steel central tube and base.</p> <p>Portemanteau sur pied entièrement en métal. Crochets en zamak, tube central et base en acier peint en époxy.</p> <p>Perchero de pie realizado en metal. Pomos colgadores de zamak, tubo central y base de acero barnizado con polvos epoxídicos.</p> <p>Vollständig aus Metall gefertigter Garderobenständer. Zamak Aufhänger Knöpfe, zentrale Rohr und Stahlbasis mit Epoxid-Pulver beschichtet.</p>				

MET'ALL					
					
	163 cm	163 cm	163 cm	163 cm	163 cm
	ø 30 cm	ø 30 cm	ø 30 cm	ø 30 cm	ø 30 cm
CD.	1497-BO	1497-NM	1497-AR	1497-O	1497-CL
PR.	€ 228,00	€ 228,00	€ 228,00	€ 228,00	€ 278,00
CL.	BO	NM	RAL 2002	C	C
	Bianco opaco Mat white Blanc mat Blanco mate Mattweiß	Nero micaceo Micaceous black Noir micacé Nigro micaceo Schwarz glimmerhaltig	Arancione rosso Orange red Rouge orangé Rojo naranja Orange-rot	Sabbia metallizzato Metallic sand Sable métallisé Arena metalizada Sand metallic	Cromato Chrome-plated Cromé Cromado Verchromt
DS.	<p>Portabiti a piantana interamente in metallo. Testa in zama e tubo centrale in acciaio cromato o verniciato con polveri epossidiche. Base in acciaio verniciato con polveri epossidiche o in acciaio inox lucido. Standing coat stand. Head in zamak and central post in chrome-plated or powder-coated steel. Powder-coated steel or polished stainless steel base.</p> <p>Portemanteau sur pied entièrement en métal. Tête en zamak et tube central en acier chromé ou peint en époxy. Base en acier peint en époxy ou en acier inox brillant.</p> <p>Perchero de pie realizado en metal. Cabezal de zamak y cilindro central de acero cromado o barnizado con polvos epoxi. Base de acero barnizada con polvos epoxi o en acero inox brillante.</p> <p>Vollständig aus Metall gefertigter Garderobenständer. Kopf aus Zamak und Standsäule aus verchromtem oder pulverbeschichtetem Stahl. Fuß aus Stahl mit Epoxidpulverlackierung oder aus poliertem Edelstahl.</p>				
					
	<p>4 ganci hooks crochets ganchos Haken</p>				

BATTISTA

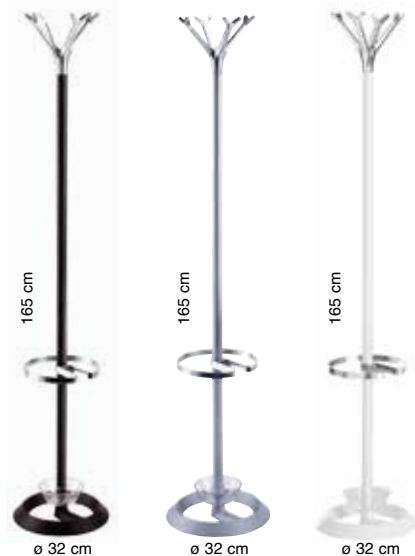

CD.	1695 (N)	1695 (GA)	1695 (BO)	1696 (N)	1696 (GA)	1696 (BO)	1692 (N)	1692 (GA)	1692 (BO)	1697
PR.	€ 427,00	€ 427,00	€ 427,00	€ 458,00	€ 458,00	€ 458,00	€ 218,00	€ 218,00	€ 218,00	€ 88,00
CL.	N	GA	BO	N	GA	BO	N	GA	BO	AL

DS. Portabiti in acciaio e ghisa verniciati, testa in alluminio lucidato. Coat stand made in powder-coated steel and cast iron, polished aluminum top.
 Portemanteau en acier et fonte peints, tête en aluminium poli. Perchero en acero y hierro fundido pintados, cabeza en aluminio pulido.
 Garderobenständer aus pulverbeschichtetem Stahl und Gusseisen, Kopf aus poliertem Aluminium.

Portabiti in acciaio e ghisa verniciati, testa e anello in alluminio lucidato e particolari in tecnopolimero. Coat stand made in powder-coated steel and cast iron, polished aluminum top and umbrella ring and high-tech polymer details.
 Portemanteau en acier et fonte peints, tête et anneau porte-parapluie en aluminium poli et détails en technopolymère. Perchero en acero y hierro fundido pintados, cabeza en aluminio pulido y detalles en tecnopolimero.
 Garderobenständer aus pulverbeschichtetem Stahl und Gusseisen, Kopf aus poliertem Aluminium und Details aus Technopolymer.

Portaombrelli in acciaio e ghisa verniciati, anello in alluminio lucidato e particolari in tecnopolimero. Umbrella stand made in powder-coated steel and cast iron, polished aluminum ring and high-tech polymer details.
 Porte-parapluies en acier et fonte peints, anneau en aluminium poli et détails en technopolymère. Paragüero en acero y hierro fundido pintados, anillo en aluminio pulido y detalles en tecnopolimero.
 Schirmständer aus pulverbeschichtetem Stahl und Gusseisen, Ring aus poliertem Aluminium und Details aus Technopolymer.

Gancio portabiti in alluminio lucidato. Polished aluminum hook.
 Crochet en aluminium poli. Gancho en aluminio pulido. Haken aus poliertem Aluminium.

8
ganci
hooks
crochets
ganchos
Haken

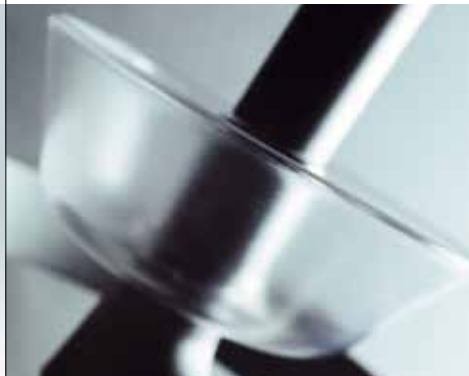

BATTISTA



CD.	1695-I (N)	1695-I (GA)	1695-I (BO)	1696-I (N)	1696-I (GA)	1696-I (BO)	1692-I (N)	1692-I (GA)	1692-I (BO)
PR.	€ 447,00	€ 447,00	€ 447,00	€ 478,00	€ 478,00	€ 478,00	€ 238,00	€ 238,00	€ 238,00
CL.	N	GA	BO	N	GA	BO	N	GA	BO

DS. Portabiti in acciaio verniciato, testa in alluminio lucidato, base in acciaio inox.
Coat stand made in powder-coated steel, polished aluminum top, stainless steel base.
Portemanteau en acier peint, tête en aluminium poli, base inox.
Perchero en acero pintado, cabeza en aluminio pulido, base inox.
Garderobenständer aus pulverbeschichtetem Stahl, Kopf aus poliertem Aluminium, Fuß aus Edelstahl.

Portabiti in acciaio verniciato, testa e anello in alluminio lucidato e particolari in tecnopolimero. Base in acciaio inox.
Coat stand made in powder-coated steel, polished aluminum top and umbrella ring and high-tech polymer details. Stainless steel base.
Portemanteau en acier peint, tête et anneau porte-parapluie en aluminium poli et détails en technopolymère. Base inox.
Perchero en acero ecubierto, cabeza en aluminio pulido y detalles en tecnopolimero. Base inox.
Garderobenständer aus pulverbeschichtetem Stahl, Kopf aus poliertem Aluminium und Details aus Technopolymer. Fuß aus Edelstahl.

Portaombrelli in acciaio verniciato, anello in alluminio lucidato e particolari in tecnopolimero, base in acciaio inox.
Umbrella stand made in powder-coated steel, polished aluminum ring and high-tech polymer details. Stainless steel base.
Porte-parapluies en acier peint, anneau en aluminium poli et détails en technopolymère. Base inox.
Paraguero en acero pintado, anillo en aluminio pulido y detalles en tecnopolimero. Base inox.
Schirmständer aus pulverbeschichtetem Stahl, Ring aus poliertem Aluminium und Details aus Technopolymer. Fuß aus Edelstahl.

8
ganci
hooks
crochets
ganchos
Haken



BATTISTA COLOR				
				
	161 cm	161 cm	161 cm	161 cm
	ø 30 cm	ø 30 cm	ø 30 cm	ø 30 cm
CD.	1698-BO	1698-N	1698-CU	1698-O
PR.	€ 298,00	€ 298,00	€ 298,00	€ 298,00
CL.	BO	N	RAL 8023	
	Bianco opaco Matt white Blanc mat Blanco mate Mattweiß	Nero opaco Matt black Noir mat Nigro mate Mattschwarz	Marrone cuoio Leather brown Brun orangé Marron cuero Lederbraun	Sabbia metallizzato Metallic sand Sable métallisé Arena metalizada Sand metallic
DS.	<p>Portabiti a piantana interamente in metallo. Testa in alluminio, tubo centrale e base in acciaio verniciati con polveri epossidiche. Standing coat stand. Powder coated aluminum head, powder coated steel central post and base Portemanteau sur pied entièrement en métal. Tête en aluminium, tube central et base en acier peint en époxy. Perchero de pie realizado en metal. Cabezal de aluminio, cilindro central y base de acero barnizado con polvos epoxi. Vollständig aus Metall gefertigter Garderobenständer. Kopf aus Aluminium, Standsäule und Fuß aus pulverbeschichtetem Stahl.</p>			
				
	<p>8 ganci hooks crochets ganchos Haken</p>			

<p>STELLA</p>  <p>179 cm 35 cm 35 cm</p>	<p>MAESTRALE</p>  <p>161 cm ø 55 cm</p>	<p>QUADRANGOLO</p>  <p>164 cm 35 cm 35 cm</p> 	<p>QUADRANGOLO</p>  <p>164 cm 35 cm 35 cm</p> 
<p>CD. 1499-RC PR. € 490,00 CL. RAL 3003</p>	<p>1482-TM € 968,00</p>	<p>1488-RN € 228,00</p>	<p>1488-BO € 189,00</p>
<p>Rosso rubino Ruby red Rouge rubis Rojo rubí Rubinrot</p>	<p>Tinto ebano Ebony finish Teinté ébène Teñida color ebano Ebenholzoptik</p>	<p>Testa bianca White top Tête blanche Cabeza blanca Weisser Kopf</p>	<p>BO Testa bianca White top Tête blanche Cabeza blanca Weisser Kopf</p>
<p>DS. Portabiti in acciaio verniciato con polveri epossidiche. Pomoli in ottone e viti in acciaio placcato oro. Coat stand in powder coated steel. Brass knobs and gold plated screws. Portemanteau en acier peint en époxy. Pommeaux en laiton et vis en acier plaqué or. Perchero de pie en acero barnizado. Pomos en latón y tornillos dorados. Garderobenständer aus pulverbeschichtetem Stahl mit Messingknöpfen und vergoldeten Schrauben.</p>  <p>9 ganci hooks crochets ganchos Haken</p>	<p>Portabiti in legno multistrato, con pomoli in metallo tornito color bronzo. Coat stand in plywood, with bronze finish turned metal knobs. Portemanteau en bois multicouches, avec pommeaux en métal bronze. Perchero en madera multicapa, con pomelos de metal bronze. Kleiderständer aus mehrschichtigem Holz und Knöpfen aus bronzefarbenem Metall.</p>  <p>15 ganci hooks crochets ganchos Haken</p>	<p>Portabiti acciaio verniciato finitura legno e bianco. Testa polycarbonato bianco. Coat stand painted steel (wood / white finish). White polycarbonate top Portemanteau acier peint finition bois et blanc. Tête en polycarbonate blanc. Perchero de pie en acero pintado (acabados en madera y blanco) Cabeza en polycarbonato blanco. Garderobenständer aus Stahl, lackiert (Holzdekor und weiß), Kopf aus weißem Polykarbonat.</p>  <p>8 ganci hooks crochets ganchos Haken</p>	<p>Portabiti in acciaio verniciato e polycarbonato. Coat stand made in powder-coated steel and polycarbonate. Portemanteau en acier peint et polycarbonate. Perchero en acero pintado y polycarbonato. Garderobenständer aus pulverbeschichtetem Stahl und Polycarbonat.</p>  <p>8 ganci hooks crochets ganchos Haken</p>

SWING

**1486-N****€ 196,00**

N

Nero
Black
Noir
Negro
Schwarz

**1486-B****€ 196,00**

B

Bianco
White
Blanc
Blanco
Weiß

**1486-AR****€ 196,00**

RAL 2002

Arancione rosso
Orange red
Rouge orangé
Rojo naranja
Orange-rot

**1486-OT****€ 196,00**

RAL 5021

Blu acqua
Water blue
Bleu turquoise
Azul agua
Wasserblau

DS.

8
ganci
hooks
crochets
ganchos
Haken

Portabiti in acciaio verniciato lucido e tecnopolimero lucido o policarbonato.
Coat stand made in glossy powder-coated steel and glossy high-tech polymer or polycarbonate.
Portemanteau en acier peint brillant et technopolymère brillant ou polycarbonate.
Perchero en acero pintado brillante y tecnopolimero brillante o policarbonato.
Garderobenständer aus glänzendem pulverbeschichtetem Stahl und glänzendem Technopolymer oder Polycarbonat.



Portaombrelli asportabile.
Removable umbrella-holder.
Porte-parapluies emportable.
Paragüero exportable.
Demontierbarer
Schirmhalter.



ELK



1476 (N)

€ 196,00

N

Testa nera
Black top
Tête noire
Cabeza negra
Schwarzer Kopf



1476-GGA

€ 228,00

GA

Testa grigio argento
Silver grey top
Tête gris argent
Cabeza gris plata
Silbergrauer Kopf

KING



1485-GA

€ 168,00

GA

Portabiti in acciaio verniciato, tecnopolimero e policarbonato.
Coat stand in powder-coated steel, high-tech polymer and polycarbonate.

Portemanteau en acier peint, technopolymère et polycarbonate.
Perchero en acero pintado, tecnopolimero y policarbonato.
Garderobenständer aus pulverbeschichtetem Stahl, Technopolymer und Polycarbonat.

CD.

PR.

CL.

DS.

Portabiti in acciaio verniciato, tecnopolimero e tecnopolimero verniciato.
Coat stand made in powder-coated steel, high-tech polymer or painted high-tech polymer.
Portemanteau en acier peint, technopolymère ou technopolymère peint.
Perchero en acero pintado, tecnopolimero o tecnopolimero pintado.
Garderobenständer aus pulverbeschichtetem Stahl, Technopolymer oder beschichtetem Technopolymer.



8
ganci
hooks
crochets
ganchos
Haken



Portaombrelli asportabile.
Removable umbrella-holder.
Porte-parapluies emportable.
Paragüero exportable.
Demontierbarer Schirmhalter.



8
ganci
hooks
crochets
ganchos
Haken

Portaombrelli asportabile.
Removable umbrella-holder.
Porte-parapluies emportable.
Paragüero exportable.
Demontierbarer Schirmhalter.

GIOIA



167 cm
ø 39 cm



167 cm
ø 39 cm

CD.	1489-N
PR.	€ 178,00
CL.	N Nero Black Noir Negro Schwarz

CD.	1489-B
PR.	€ 178,00
CL.	B Bianco White Blanc Blanco Weiß

DS. Portabiti in acciaio verniciato lucido e tecnopolimero lucido.
Coat stand made in glossy powder-coated steel and glossy high-tech polymer.
Portemanteau en acier peint brillant et technopolymère brillant.
Perchero en acero pintado brillante y tecnopolimero brillante.
Garderobenständer aus glänzendem pulverbeschichtetem Stahl und glänzendem Technopolymer.



8
ganci
hooks
crochets
ganchos
Haken



Portaombrelli asportabile.
Removable umbrella-holder.
Porte-parapluies emportable.
Paragüero exportable.
Demontierbarer Schirmhalter.



EVA



164 cm
ø 39 cm



164 cm
ø 39 cm

CD.	1483-N
PR.	€ 69,50 cad each
CD.	1483M-N
PR.	€ 59,80 cad each ≥ 6 pz
CL.	N

CD.	1483-GA
PR.	€ 69,50 cad each
CD.	1483M-GA
PR.	€ 59,80 cad each ≥ 6 pz
CL.	GA

DS. Portabiti in acciaio verniciato e tecnopolimero.
Coat stand made in powder-coated steel and high-tech polymer.
Portemanteau en acier peint et technopolymère.
Perchero en acero pintado y tecnopolimero.
Garderobenständer aus pulverbeschichtetem Stahl und Technopolymer.



12
ganci
hooks
crochets
ganchos
Haken



Portaombrelli asportabile.
Removable umbrella-holder.
Porte-parapluies emportable.
Paragüero exportable.
Demontierbarer Schirmhalter.

≥ 6 pz : Prezzo unitario per ordini ≥ 6 pz / Unit price for orders ≥ 6 pcs. / Prix unitaire pour commandes ≥ 6 pcs. / Precio por unidad para pedidos ≥ 6 pzs. / Stückpreis für Bestellungen ≥ 6 St.

HOOK				
				<p>Componibile in lunghezza Modular in length Composable en longueur Componible en longitud Modulare Länge</p>
CD.	1562 (N)	1563 (N)	1564 (N)	
PR.	€ 49,00	€ 68,00	€ 79,00	
CL.	N	N	N	
DS.	<p>Portabiti da parete cromato con ganci in tecnopolimero. Componibile in lunghezza. Chrome-plated wall-mounted coat rail with hooks in high-tech polymer. Modular in length. Portemanteau mural chromé avec crochets en technopolymère. Composable en longueur. Perchero de pared cromado con ganchos en tecnopolimero. Componible en longitud. Verchromte Wandgarderobe mit Haken aus Technopolymer. Modulare Länge.</p>			
DUO				
		<p>Componibile in lunghezza Modular in length Composable en longueur Componible en longitud Modulare Länge</p>		
CD.	1519-N	1519-BO	1519-V	1519-BE
PR.	€ 39,00 cad each	€ 39,00 cad each	€ 39,00 cad each	€ 39,00 cad each
CD.	1519M-N	1519M-BO	1519M-V	1519M-BE
PR.	€ 32,00 cad each ≥ 6 pz	€ 32,00 cad each ≥ 6 pz	€ 32,00 cad each ≥ 6 pz	€ 32,00 cad each ≥ 6 pz
CL.	N	BO	V	BE
DS.	<p>Portabiti da parete in tecnopolimero. Componibile in lunghezza. Wall-mounted coat rail in high-tech polymer. Modular in length. Portemanteau mural en technopolymère. Composable en longueur. Perchero de pared en tecnopolimero. Componible en longitud. Wandgarderobe aus Technopolymer. Modulare Länge.</p>			

≥ 6 pz : Prezzo unitario per ordini ≥ 6 pz / Unit price for orders ≥ 6 pcs. / Prix unitaire pour commandes ≥ 6 pcs. / Precio por unidad para pedidos ≥ 6 pzs. / Stückpreis für Bestellungen ≥ 6 St.

RAPID

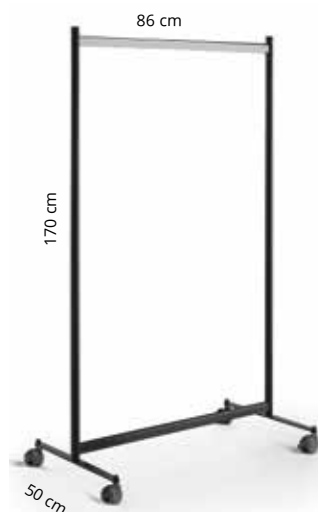

SPEECH STANDER

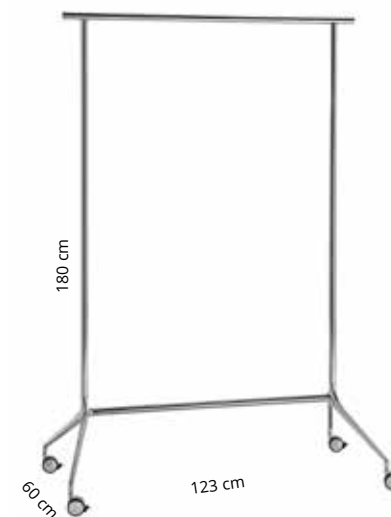

CD.

5214-N

5215-N

1SS12-C

PR.

€ 318,00

€ 328,00

€ 496,00

CL.

N

N

C

DS.

Stander portabiti in acciaio su ruote con freno. Barra portabiti in acciaio cromato
 Steel free-standing coat stand on casters with stoppers. Chrome-plated steel clothes rail
 Portemanteau stander en acier avec roulettes avec frein. Barre porte-vêtements en acier chromé
 Percheros de acero con ruedas con freno. Barra de colgar de acero cromado
 Kleiderständer aus Stahl, mit Rollen mit Bremsen. Kleiderstange aus verchromtem Stahl

Stander portabiti in acciaio cromato, con base in alluminio lucidato montata su ruote con freno e struttura portante in acciaio cromato.
 Chrome-plated steel free-standing coat stand, with polished aluminum base mounted on casters with stoppers and chrome-plated steel support structure.

Portemanteau stander en acier chromé, avec base en aluminium poli montée sur des roulettes avec frein et structure portante en acier chromé.

Percheros de acero cromado, con base de aluminio brillante montada sobre ruedas con freno y estructura portante de acero cromado.
 Kleiderständer aus verchromtem Stahl, Untergestell aus poliertem Aluminium auf Rollen mit Bremsen und Halterung aus verchromtem Stahl



Vedi articoli disponibili a pag. 192.
 See the available items at page 192
 Voir les articles disponibles à la page 192
 Ver los artículos disponibles en la página 192
 Bitte beachten Sie die verfügbaren Produkte auf Seite 192



Vedi articoli disponibili a pag. 192.
 See the available items at page 192
 Voir les articles disponibles à la page 192
 Ver los artículos disponibles en la página 192
 Bitte beachten Sie die verfügbaren Produkte auf Seite 192



AMBROGIO

moduli base
start units

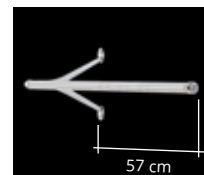
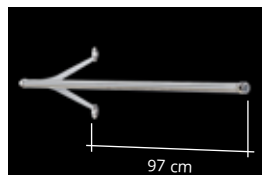
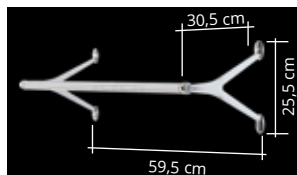
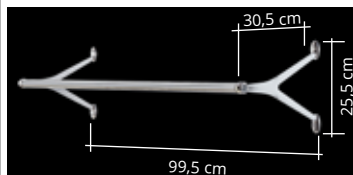

moduli seguito
add-on units

CD.	1546	1547	1548	1549
PR.	€ 218,00	€ 214,00	€ 154,00	€ 150,00
CL.	C	C	C	C

DS. Portabiti da parete in alluminio lucido e acciaio cromato. Componibile in lunghezza. Wall-mounted coat rail in polished aluminium and chrome-plated steel. Modular in length. Portemanteau mural en aluminium poli et acier chromé. Composable en longueur. Perchero de pared en aluminio pulido y acero cromado. Componible en longitud. Wandgarderobe aus poliertem Aluminium und verchromtem Stahl. Modulare Länge.

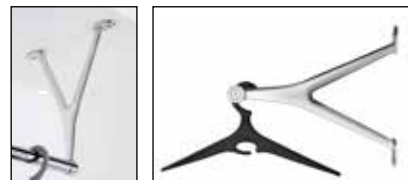

AMBROGINO

moduli base
start units

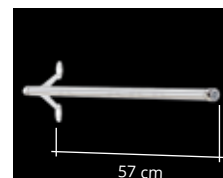
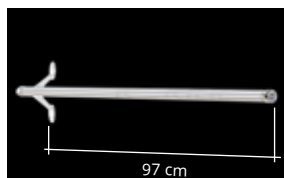
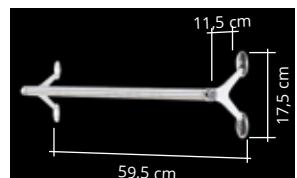

moduli seguito
add-on units



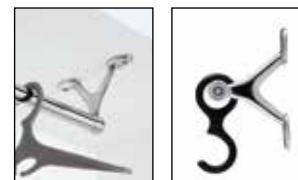

CD.	1551	1552	1553	1554
PR.	€ 208,00	€ 204,00	€ 144,00	€ 140,00
CL.	C	C	C	C



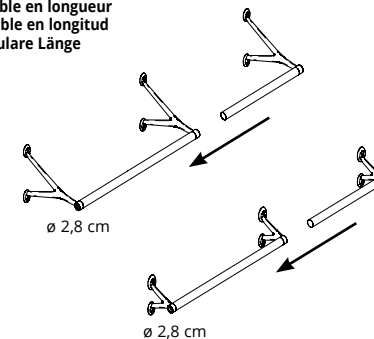

DS. Portabiti da parete in alluminio lucido e acciaio cromato. Componibile in lunghezza. Wall-mounted coat rail in polished aluminium and chrome-plated steel. Modular in length. Portemanteau mural en aluminium poli et acier chromé. Composable en longueur. Perchero de pared en aluminio pulido y acero cromado. Componible en longitud. Wandgarderobe aus poliertem Aluminium und verchromtem Stahl. Modulare Länge.







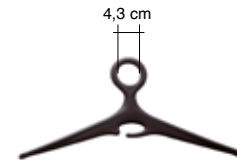



Componibile in lunghezza
Modular in length
Composable en longueur
Componible en longitud
Modulare Länge

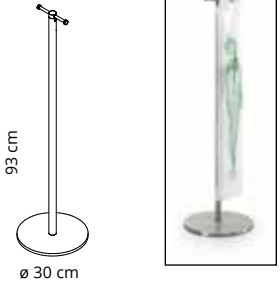

HANGER		  	
	 <p>42 cm</p> <p>1527/4-N</p>		 <p>42 cm</p> <p>1527/4-B</p>
CD.			
PR.	€ 29,80 (4 pcs)		€ 29,80 (4 pcs)
CL.	N		B
DS.	<p>Grucce portabiti in ABS. ABS hangers. Cintres en ABS. Perchas en ABS. Kleiderbügel aus ABS.</p>		

OMETTO				
	 <p>41,5 cm</p> <p>1537/4 (N)</p>	 <p>4,3 cm</p> <p>41,5 cm</p> <p>1538/4</p>		 <p>4,3 cm</p> <p>16 cm</p> <p>7 cm</p> <p>1529/8</p>
CD.				
PR.	€ 36,00 (4 pcs)	€ 39,00 (4 pcs)		€ 48,00 (8 pcs)
CL.	N	N		N
DS.	<p>Grucce portabiti in polipropilene. Polypropylene hangers. Cintres en polypropylène. Perchas en polipropileno. Kleiderbügel aus Polypropylen.</p>	<p>Grucce portabiti in polipropilene. Polypropylene hangers. Cintres en polypropylène. Perchas en polipropileno. Kleiderbügel aus Polypropylen.</p>	<p>Ganci portabiti in polipropilene. Polypropylene hooks. Crochets en polypropylène. Ganchos en polipropileno. Haken aus Polypropylen.</p>	

<p>PLAT</p> 		<p>KABO</p> 	
<p>CD. 1431-GL</p>	<p>CD. 1431-R</p>	<p>CD. 1430-B</p>	<p>CD. 1430-R</p>
<p>PR. € 129,00</p>	<p>PR. € 129,00</p>	<p>PR. € 229,00</p>	<p>PR. € 229,00</p>
<p>CL. GL</p>	<p>CL. R</p>	<p>CL. B</p>	<p>CL. R</p>
<p>DS. Portaoggetti realizzato in gres colorato. Multifunctional object made of coloured stoneware. Objet multifonctions réalisé en grès coloré. Objeto multifuncional de gres de colores. Mehrzweckobjekt aus farbigem Steingut.</p>		<p>DS. Portaombrelli / portaoggetti realizzato in gres colorato. Umbrella stand / multifunctional object made of coloured stoneware. Porte-parapluies / Objet multifonctions réalisé en grès coloré. Paragüero / objeto multifuncional de gres de colores. Schirmständer / Mehrzweckobjekt aus farbigem Steingut.</p>	
<p>SET</p> 		<p>PIOGGIA</p> 	
<p>CD. 1SECBA7-IN</p>	<p>CD. 1SECBA7-I</p>	<p>CD. 510-GA</p>	
<p>PR. € 218,00</p>	<p>PR. € 228,00</p>	<p>PR. € 208,00</p>	
<p>CL. I/N</p>	<p>CL. I</p>	<p>CL. GA</p>	
			
<p>DS. Colonnina in acciaio inossidabile satinato, con portaborse e porta buste per ombrelli realizzato in acciaio inossidabile satinato. Pole made of satin stainless steel with bag holder and umbrella bag holder made of satin stainless steel. Colonnette en acier inox satiné avec porte-sac et porte-housse pour parapluies réalisés en acier inox satiné. Poste en acero inoxidable satinado con percha para bolsos y fundas de paraguas en acero inoxidable satinado. Standsäule aus mattem Edelstahl mit Taschenhalter und Regenschirmbeutelspender aus mattem Edelstahl.</p>		<p>DS. Portaombrelli a rastrelliera su ruote in acciaio verniciato e tecnopolimero. Umbrella-rack on castors in epoxy-coated steel and high-tech polymer. Porte-parapluies à râtelier sur roulettes en acier peint époxy et technopolymère. Paragüero con ruedas, en acero pintado y tecnopolimero. Schirmständer-Gestell aus pulverbeschichtetem Stahl und Technopolymer, auf Rollen.</p>	

12 L

HI-TECH



PER CODICI
FOR CODES
414 (N)
414M (N)



CD.	414 (N)	414-GR	414-BO
PR.	€ 15,80 ^{cad} each	€ 16,80 ^{cad} each	€ 16,80 ^{cad} each
CD.	414M (N)	414M-GR	414M-BO
PR.	€ 13,80 ^{cad} each ≥ 10 pz	€ 14,80 ^{cad} each ≥ 10 pz	€ 14,80 ^{cad} each ≥ 10 pz
CL.	N	GR	BO

Cestino gettacarte impilabile in polipropilene.
Polypropylene stackable waste-paper bin.
Corbeille à papier empilable en polypropylène.
Papelera apilable en polipropileno.
Stapelbarer Papierkorb aus Polypropylen.



Per art. / For ref. / Pour réf. / Para ref. / Für Art. 414 (N), 414-GR, 414-BO			Per art. / For ref. / Pour réf. / Para ref. / Für Art. 414 (N), 414-GR, 414-BO			
CD.	404 (N)	404-GR	404-BO	415 (N)	415-GR	415-BO
PR.	€ 8,20 ^{cad} each	€ 9,20 ^{cad} each	€ 9,20 ^{cad} each	€ 11,00 ^{cad} each	€ 11,70 ^{cad} each	€ 11,70 ^{cad} each
CD.	404M (N)	404M-GR	404M-BO	415M (N)	415M-GR	415M-BO
PR.	€ 7,60 ^{cad} each ≥ 10 pz	€ 8,20 ^{cad} each ≥ 10 pz	€ 8,20 ^{cad} each ≥ 10 pz	€ 10,00 ^{cad} each ≥ 10 pz	€ 10,50 ^{cad} each ≥ 10 pz	€ 10,50 ^{cad} each ≥ 10 pz
CL.	N	GR	BO	N	GR	BO

Reggisacchetto in polipropilene.
Polypropylene liner holder.
Anneau porte-sac en polypropylène.
Sujeta bolsas en polipropileno.
Müllsackhalter aus Polypropylen.

















Reggisacchetto per la raccolta differenziata in polipropilene.
Polypropylene liner holder for waste separation.
Anneau porte-sac en polypropylène pour le tri sélectif des déchets.
Sujeta bolsas en polipropileno para la recogida selectiva.
Mülltrennring und Müllsackhalter, aus Polypropylen.

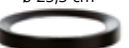
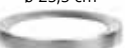
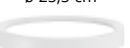









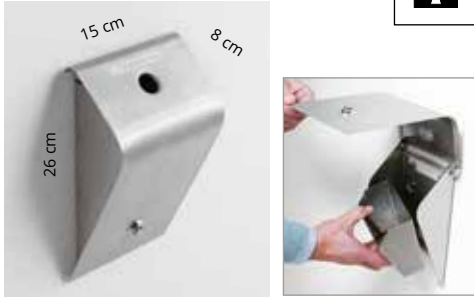

<p>DIVIDO</p>  <p>44,5 cm 22 cm 31 cm</p>	<p>20 L</p>		  <p>429</p>
<p>CD. 427-GR</p>	<p>€ 49,50</p>		<p>€ 12,40</p>
<p>CL. GR</p>			
<p>DS. Cestino per la raccolta differenziata in tecnopolimero. Completo di 1 divisorio. Bin for waste separation, made in high-tech polymer. Equipped with 1 partition. Corbeille en technopolymère pour le tri sélectif des déchets. Avec un séparateur. Papelera para recogida selectiva en tecnopolimero. Completo de 1 separador. Abfallbehälter zur Mülltrennung, aus Technopolymer. 1 Trennelement inbegriffen.</p>			<p>5 etichette per colore (tot. 30) 5 labels per colour (tot. 30) 5 étiquettes par couleur (tot. 30) 5 etiquetas para color (tot. 30) 5 Etiketten pro Farbe (insg. 30)</p> <p>Etichette in 6 colori per art. 427-GR. Set of labels in 6 colours for code 427-GR. Jeu d'étiquettes en 6 couleurs pour réf. 427-GR. Set de etiquetas en 6 colores para cod. 427-GR. Selbstklebeetiketten in 6 Farben für Art. 427-GR.</p>
<p>SWING</p>  <p>25 cm 25 cm 32 cm 25 cm 25 cm 32 cm 25 cm 25 cm 32 cm 25 cm 25 cm 32 cm</p>	<p>13 L</p>	 <p>5 cm 26 cm 26 cm 5 cm 26 cm 26 cm 5 cm 26 cm 26 cm 5 cm 26 cm 26 cm</p>	
<p>CD. 421-N 421-B 421-AR 421-OT</p>	<p>€ 26,80</p>	<p>€ 28,50</p>	<p>€ 15,80 € 17,80 € 17,80 € 17,80</p>
<p>PR. N B RAL 2002 RAL 5021</p>			
<p>CL. N B RAL 2002 RAL 5021</p>			
<p>DS. Cestino gettacarte impilabile in tecnopolimero lucido. Stackable waste-paper bin in glossy high-tech polymer. Corbeille à papier empilable en technopolymère brillant. Papelera apilable en tecnopolimero brillante. Stapelbarer Papierkorb aus glänzendem Technopolymer.</p>			<p>Reggisacchetto in tecnopolimero lucido per art. 421-N, 421-B, 421-AR e 421-OT. Glossy high-tech polymer liner holder for codes 421-N, 421-B, 421-AR and 421-OT. Anneau porte-sac en technopolymère brillant pour réf. 421-N, 421-B, 421-AR et 421-OT. Sujeta bolsas en tecnopolimero brillante para cod. 421-N, 421-B, 421-AR y 421-OT. Müllsackhalter aus glänzendem Technopolymer für Art. 421-N, 421-B, 421-AR und 421-OT.</p>





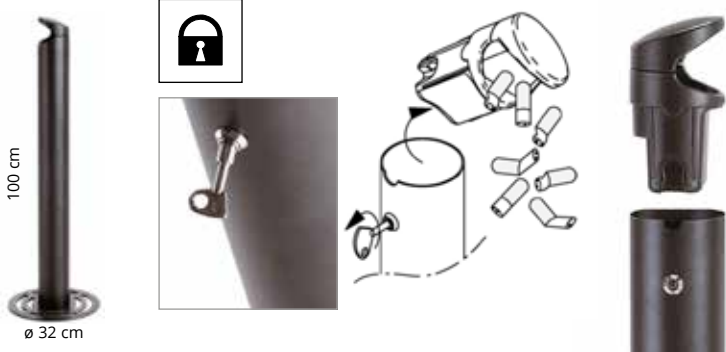



DESIGN COLLECTION		13 L		20 L		35 L		35 L		
CD.	463-BO	463-N	465-BO	465-N	462-BO	462-N	464-BO	464-N		
PR.	€ 78,00	€ 78,00	€ 108,00	€ 108,00	€ 168,00	€ 168,00	€ 198,00	€ 198,00		
CL.	BO	N	BO	N	BO	N	BO	N		
DS.	<p>Cestino gettacarte in acciaio verniciato. Waste paper bin in powder-coated steel. Corbeille à papier en acier peint. Papelera en acero pintado. Papierkorb aus pulverbeschichtetem Stahl.</p>				<p>Portaombrelli in acciaio verniciato. Umbrella stand in powder-coated steel. Porte-parapluies en acier peint. Paragüero en acero pintado. Schirmständer aus pulverbeschichtetem Stahl.</p>					
DS.	<p>Portaombrelli in acciaio verniciato. Umbrella stand in powder-coated steel. Porte-parapluies en acier peint. Paragüero en acero pintado. Schirmständer aus pulverbeschichtetem Stahl.</p>				<p>Portaombrelli con vaschetta per ombrellini pieghevoli in acciaio verniciato Powder coated steel umbrella stand with tray for folding umbrellas. Porte-parapluies avec bac pour parapluies pliables en acier peint Paragüero con cubeta para paraguas plegables en acero pintado Schirmständer aus pulverbeschichtetem Stahl mit Wanne für Knirpse.</p>					
DS.	<p>Portaombrelli in acciaio verniciato. Umbrella stand in powder-coated steel. Porte-parapluies en acier peint. Paragüero en acero pintado. Schirmständer aus pulverbeschichtetem Stahl.</p>				<p>Portaombrelli in acciaio verniciato. Umbrella stand in powder-coated steel. Porte-parapluies en acier peint. Paragüero en acero pintado. Schirmständer aus pulverbeschichtetem Stahl.</p>					

<p>HI-TECH</p> <p>14 L</p> 			<p>HI-TECH</p> <p>14 L</p>			<p>HI-TECH</p> 															
 <p>32 cm</p> <p>ø 25 cm</p> <p>411-N</p>			 <p>32 cm</p> <p>ø 25 cm</p> <p>411-GA</p>			 <p>32 cm</p> <p>ø 25 cm</p> <p>411-BO</p>			 <p>32 cm</p> <p>ø 25 cm</p> <p>412-F (N)</p>			 <p>32 cm</p> <p>ø 25 cm</p> <p>412-GAF</p>			 <p>32 cm</p> <p>ø 25 cm</p> <p>412-BOF</p>			 <p>ø 25,5 cm</p> <p>418 (N)</p>	 <p>ø 25,5 cm</p> <p>418-GR</p>	 <p>ø 25,5 cm</p> <p>418-BO</p>	 <p>ø 25,5 cm</p> <p>419 (N)</p>
<p>CD. 411-N</p> <p>PR. € 43,80^{cad} each</p>			<p>CD. 411-GA</p> <p>PR. € 43,80^{cad} each</p>			<p>CD. 411-BO</p> <p>PR. € 43,80^{cad} each</p>			<p>CD. 412-F (N)</p> <p>PR. € 48,50^{cad} each</p>			<p>CD. 412-GAF</p> <p>PR. € 48,50^{cad} each</p>			<p>CD. 412-BOF</p> <p>PR. € 48,50^{cad} each</p>			<p>CD. 418 (N)</p> <p>PR. € 11,80</p>	<p>CD. 418-GR</p> <p>PR. € 11,80</p>	<p>CD. 418-BO</p> <p>PR. € 11,80</p>	<p>CD. 419 (N)</p> <p>PR. € 12,80</p>
<p>CD. 411M-N</p> <p>PR. € 38,80^{cad} each ≥ 8 pz</p>			<p>CD. 411M-GA</p> <p>PR. € 38,80^{cad} each ≥ 8 pz</p>			<p>CD. 411M-BO</p> <p>PR. € 38,80^{cad} each ≥ 8 pz</p>			<p>CD. 412M-F (N)</p> <p>PR. € 39,80^{cad} each ≥ 8 pz</p>			<p>CD. 412M-GAF</p> <p>PR. € 39,80^{cad} each ≥ 8 pz</p>			<p>CD. 412M-BOF</p> <p>PR. € 39,80^{cad} each ≥ 8 pz</p>						
<p>CL. N</p>			<p>CL. GA</p>			<p>CL. BO</p>			<p>CL. N</p>			<p>CL. GA</p>			<p>CL. BO</p>			<p>CL. N</p>			
<p>DS. Cestino gettacarte in acciaio verniciato e tecnopolimero. Waste paper bin in powder-coated steel and high-tech polymer. Corbeille à papier en acier peint et technopolymère. Papelerera en acero pintado y tecnopolimero. Papierkorb aus pulverbeschichtetem Stahl und Technopolymmer.</p>			<p>DS. Cestino gettacarte in acciaio forato verniciato e tecnopolimero. Waste paper bin in powder-coated perforated steel and high-tech polymer. Corbeille à papier en acier perforé peint et technopolymère. Papelerera en acero perforado pintado y tecnopolimero. Papierkorb aus pulverbeschichtetem gelochtem Stahl und Technopolymmer.</p>			<p>DS. Reggisacchetto in polipropilene. Polypropylene liner holder. Anneau porte-sac en polypropylène. Sujeta bolsas en polipropileno. Müllsackhalter aus Polypropylen.</p>			<p>DS. Reggisacchetto raccolta differenziata. Liner holder for waste separation. Anneau porte-sac pour le tri sélectif. Sujeta bolsas recogida selectiva. Mülltrennring und Müllsackhalter</p>												
<p>HI-TECH</p> <p>22 L</p> 																					
 <p>50 cm</p> <p>ø 25 cm</p> <p>506-N</p>		 <p>50 cm</p> <p>ø 25 cm</p> <p>506-GA</p>		 <p>50 cm</p> <p>ø 25 cm</p> <p>506-BO</p>																	
<p>CD. 506-N</p> <p>PR. € 68,00^{cad} each</p>		<p>CD. 506-GA</p> <p>PR. € 68,00^{cad} each</p>		<p>CD. 506-BO</p> <p>PR. € 68,00^{cad} each</p>																	
<p>CD. 506M-N</p> <p>PR. € 58,00^{cad} each ≥ 6 pz</p>		<p>CD. 506M-GA</p> <p>PR. € 58,00^{cad} each ≥ 6 pz</p>		<p>CD. 506M-BO</p> <p>PR. € 58,00^{cad} each ≥ 6 pz</p>																	
<p>CL. N</p>		<p>CL. GA</p>		<p>CL. BO</p>																	
<p>DS. Portaombrelli in acciaio verniciato e tecnopolimero. Umbrella stand in powder-coated steel and high-tech polymer. Porte-parapluies en acier peint et technopolymère. Paragüero en acero pintado y tecnopolimero. Schirmständer aus pulverbeschichtetem Stahl und Technopolymmer.</p>																					

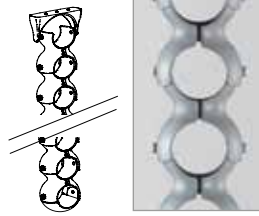
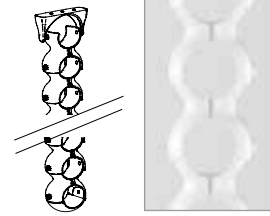
≥ 6 pz : Prezzo unitario per ordini ≥ 6 pz / Unit price for orders ≥ 6 pcs. / Prix unitaire pour commandes ≥ 6 pcs. / Precio por unidad para pedidos ≥ 6 pzs. / Stückpreis für Bestellungen ≥ 6 St.

≥ 8 pz : Prezzo unitario per ordini ≥ 8 pz / Unit price for orders ≥ 8 pcs. / Prix unitaire pour commandes ≥ 8 pcs. / Precio por unidad para pedidos ≥ 8 pzs. / Stückpreis für Bestellungen ≥ 8 St.

<p>PIAZZA</p>  	<p>SMILE</p>  	
<p>CD. 435-I</p>	<p>CD. 430-I</p>	
<p>PR. € 258,00</p>	<p>PR. € 368,00</p>	
<p>CL. Outdoor</p> 	<p>CL. Outdoor</p> 	
<p>DS. Posacenere da parete in acciaio inox AISI 304. Wall ashtray in stainless steel AISI 304. Cendrier mural en acier inox AISI 304. Cenicero de pared en acero inoxidable AISI 304. Wand-Aschenbecher aus rostfreiem Stahl AISI 304.</p>	<p>DS. Cestino gettacarte da parete in acciaio inox AISI 304. Wall waste bin in stainless steel AISI 304. Corbeille à papier murale en acier inox AISI 304. Papelera de pared en acero inoxidable AISI 304. Wand-Papierkorb aus rostfreiem Stahl AISI 304.</p>	
<p>ESTERNO</p>  		
<p>CD. 307-NM</p>		
<p>PR. € 448,00</p>		
<p>CL. NM Outdoor</p> 		
<p>DS. Posacenere in alluminio per esterni con base autoportante in acciaio. Outdoor aluminium ashtray with free-standing steel base. Cendrier pour l'extérieur en aluminium avec base autoportante en acier. Cenicero en aluminio para exterior con base auto-portante en acero. Standascher aus Aluminium für den Außenbereich, freistehend, Bodenplatte aus Stahl.</p>		

<p>HI-TECH</p> 	<p>UP</p> 	<p>BISS</p> 		 <p>cod.1740-GR</p>
<p>CD. 1463</p>	<p>8740-GA</p>	<p>1740-GR</p>	<p>1740-BO</p>	
<p>PR. € 38,70 ^{cad} each</p>	<p>€ 74,80</p>	<p>€ 38,80</p>	<p>€ 39,80</p>	
<p>CL. N</p> <p>2 pz. per scatola Box of 2 pcs Condit. à 2 pcs 2 pz. por embalaje Verpackungseinheit 2 St.</p>	<p>GA</p>	<p>GR</p>	<p>BO</p>	
<p>DS.</p>	<p>Sottomano in espanso. Desk pad in foam. Sous-main en expansé. Carpetta de expandido. Schreibunterlage aus Schaumstoff.</p>	<p>Piano poggia computer / monitor in acciaio verniciato con polveri epossidiche. Computer/monitor support base made of epoxy powder-coated steel. Support pour ordinateur / écran en acier peint aux poudres époxy. Superficie de apoyo computadora / monitor de acero pintado con polvos epoxi. PC-/Monitor-Ablagefläche aus mit Epoxypulver beschichtetem Stahl.</p>	<p>Passacavi in tecnopolimero composto da 12 elementi completo di attacco a scrivania e peso. High-tech polymer cables holder with 12 elements, desk fixing bracket and terminal ballast included. Canalisation en technopolymère avec 12 éléments.Étrier de fixation au bureau et ballast inclus. Pasacables en tecnopolimero componido por 12 elementos, enganche para mesa y peso terminal incluidos. Kabelhalter aus Technopolymer, bestehend aus 12 Elementen. Komplett mit Schreibtischanschlussstück und Gewicht.</p>	
<p>OREDODICI</p> 		<p>ST DORFLES</p> 		
<p>CD. 1472-NB</p>	<p>1472-BN</p>	<p>1425-N</p>	<p>1425-BO</p>	
<p>PR. € 86,00</p>	<p>€ 86,00</p>	<p>€ 78,00</p>	<p>€ 78,00</p>	
<p>CL. N</p> <p>Numeri bianchi White numbers Chiffres blancs Numeros blancos Weisse Nummern</p>	<p>B</p> <p>Numeri neri Black numbers Chiffres noirs Numeros negros Schwarze Nummern</p>	<p>N</p>	<p>BO</p>	
<p>DS.</p>	<p>Orologio da parete in tecnopolimero. High-tech polymer wall clock. Horloge mural en technopolymère. Reloj de pared en tecnopolimero. Wanduhr aus Technopolymer.</p>	<p>Fermalibri in acciaio verniciato con polveri epossidiche. Bookends made of epoxy powder-coated steel. Serre-livres en acier peint aux poudres époxy. Sujetalibros de acero pintado con polvos epoxi. Buchstützen aus mit Epoxypulver beschichtetem Stahl.</p>		

DESK-UP		
CD. 1209 (N)	CD. 1209-GM	CD. 1209-T
PR. € 15,80 cad each	PR. € 38,80 cad each	PR. € 26,80 cad each
CL. N	CL. GM	CL. T
DS. 2 pz. per scatola Box of 2 pcs Condit. à 2 pcs 2 pz. por embalaje Verpackungseinheit 2 St.	DS. 2 pz. per scatola Box of 2 pcs Condit. à 2 pcs 2 pz. por embalaje Verpackungseinheit 2 St.	DS. 2 pz. per scatola Box of 2 pcs Condit. à 2 pcs 2 pz. por embalaje Verpackungseinheit 2 St.
DS. Vaschetta portacorrispondenza in policarbonato o tecnopolimero. Letter-tray made of polycarbonate or high-tech polymer. Bac à courrier en polycarbonate ou technopolymère. Portacorrespondencia en policarbonato o tecnopolimero. Papierablagekorb aus Polycarbonat oder Technopolymer.		
CD. 1200 (N)	CD. 1200-GM	CD. 1200-T
PR. € 15,80 cad each	PR. € 38,80 cad each	PR. € 26,80 cad each
CL. N	CL. GM	CL. T
DS. 2 pz. per scatola Box of 2 pcs Condit. à 2 pcs 2 pz. por embalaje Verpackungseinheit 2 St.	DS. 2 pz. per scatola Box of 2 pcs Condit. à 2 pcs 2 pz. por embalaje Verpackungseinheit 2 St.	DS. 2 pz. per scatola Box of 2 pcs Condit. à 2 pcs 2 pz. por embalaje Verpackungseinheit 2 St.
DS. Vaschetta portacorrispondenza in policarbonato o tecnopolimero. Letter-tray made of polycarbonate or high-tech polymer. Bac à courrier en polycarbonate ou technopolymère. Portacorrespondencia en policarbonato o tecnopolimero. Papierablagekorb aus Polycarbonat oder Technopolymer.		
CD. 1201 (N)	CD. 1201-GM	CD. 1201-T
PR. € 7,50 (4 pcs)	PR. € 15,80 (4 pcs)	PR. € 9,80 (4 pcs)
CL. N	CL. GM	CL. T
DS. Supporti per la sovrapposizione delle vaschette portacorrispondenza in policarbonato o tecnopolimero. Supports to stack the letter-trays made of polycarbonate or high-tech polymer. Supports pour superposer les bacs à courrier en polycarbonate ou technopolymère. Soportes para el apilamiento de las bandejas portacorrespondencia en policarbonato o tecnopolimero. Stützen zum Stapeln der Papierablage aus Polycarbonat oder Technopolymer.		

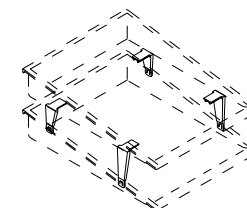

(2x) 1200-T + (1x) 1201-T

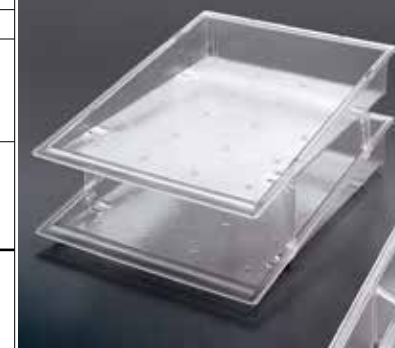

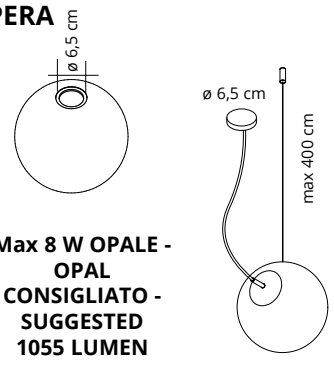
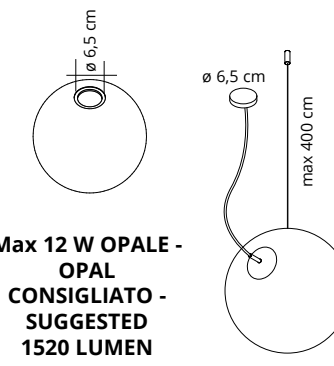
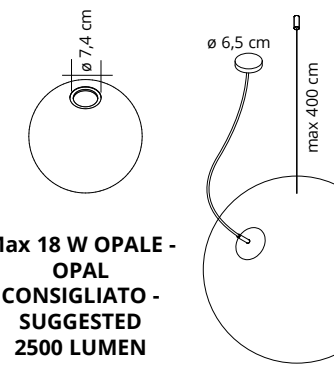

DESK-UP						
CD.	1206 (N)	1206-GM	1206-T	1208 (N)	1208-GM	1208-T
PR.	€ 28,80	€ 45,00	€ 39,50	€ 12,70	€ 22,80	€ 19,60
CL.	N	GM	T	N	GM	T
DS.	Portaoggetti in policarbonato o tecnopolimero. Object holder made of polycarbonate or high-tech polymer. Porte-objets en polycarbonate ou technopolymère. Portaobjectos en policarbonato o tecnopolimero. Objektablage aus Polycarbonat oder Technopolymer.			Portamatite in policarbonato o tecnopolimero. Pen holder made of polycarbonate or high-tech polymer. Pot à crayons en polycarbonate ou technopolymère. Portalapiceros en policarbonato o tecnopolimero. Bleistiftköcher aus Polycarbonat oder Technopolymer.		

DESK-UP					
		1271 = L 97 cm # 1272 = L 117 cm 1276 = L 157 cm #			
CD.	1271	1272	1276		
PR.	#	€ 79,50	#		
CL.	AL	AL	AL		
DS.	Profili in alluminio anodizzato per montaggio su parete - completo di 2 tappi terminali neri. Anodized aluminium profiles for wall fixing - 2 black caps included. Profiles en aluminium anodisé pour fixation au mur - avec 2 taquets noirs. Perfiles en aluminio anodizado para el montaje a pared - 2 tapas negras incluidas. Profile aus eloxiertem Aluminium zur Wandmontage - 2 Abdeckkappen inklusive.				
	(#) Disponibili solo per quantitativi, prezzi su richiesta - (#) Available in large numbers only, prices on request (#) Disponibles seulement pour quantités, prix sur demande - (#) Disponibles solo por cantidades, solicitar precios - (#) Erhältlich nur in großen Stückzahlen, Preis auf Anfrage				

	<p>OPERA</p>  <p>Max 8 W OPALE - OPAL CONSIGLIATO - SUGGESTED 1055 LUMEN</p> <p>CD. 1891</p> <p>PR. € 287,00</p>	 <p>Max 12 W OPALE - OPAL CONSIGLIATO - SUGGESTED 1520 LUMEN</p> <p>CD. 1892</p> <p>PR. € 298,00</p>	 <p>Max 18 W OPALE - OPAL CONSIGLIATO - SUGGESTED 2500 LUMEN</p> <p>CD. 1893</p> <p>PR. € 318,00</p>
CL.			
DS.	<p>Lampada LED a sospensione in tecnopolimero traslucido, con cavo regolabile in altezza. Attacco lampadina E27. Lampadina non inclusa. LED suspension lamp made of translucent technopolymer, with height-adjustable cable. E27 bulb socket. Bulb not included. Suspension LED en technopolymère translucide, avec câble réglable en hauteur. Douille E27. Ampoule non incluse. Lámpara de suspensión LED de tecnopolímero translúcido, con cable regulable en altura. Casquillo E27. Bombilla no incluida. LED-Hängeleuchte aus lichtdurchlässigem Technopolymer, mit höhenverstellbarem Kabel. E27-Glühlampen-Fassung. Glühlampe nicht enthalten.</p>		

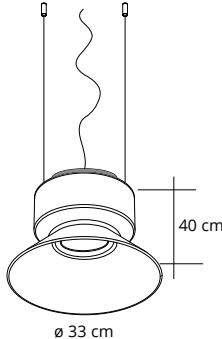

TELETA		
		
CD.	1803-RBO	1803-BBO
PR.	€ 790,00	€ 790,00
CL.	R	BO
DS.	Lampada led a sospensione in gres 6,2W - 3000K dotata nella parte superiore del paralume di un filtro con ioni d'argento per la purificazione dell'aria. Suspension led lamp 6,2W - 3000K equipped in the upper part of the lampshade with a filter containing silver ions for air purification. Lampe led à suspension 6,2W - 3000K équipée dans la partie supérieure de l'abat-jour d'un filtre contenant des ions argent pour la purification de l'air. Lámpara led de suspensión 6,2W - 3000K equipada en la parte superior de la pantalla con un filtro que contiene iones de plata para la purificación del aire. LED-Hängelampe 6,2W - 3000K, ausgestattet im oberen Teil des Lampenschirms mit einem Filter, der Silberionen zur Luftreinigung enthält.	Lampada led a sospensione in alluminio 17,3W - 3000K dotata nella parte superiore del paralume di un filtro con ioni d'argento per la purificazione dell'aria. Aluminum suspension led lamp 17,3W - 3000K equipped in the upper part of the lampshade with a filter containing silver ions for air purification. Lampe led à suspension 17,3W - 3000K équipée dans la partie supérieure de l'abat-jour d'un filtre contenant des ions argent pour la purification de l'air. Lámpara led de suspensión 17,3W - 3000K equipada en la parte superior de la pantalla con un filtro que contiene iones de plata para la purificación del aire. LED-Hängelampe 17,3W - 3000K, ausgestattet im oberen Teil des Lampenschirms mit einem Filter, der Silberionen zur Luftreinigung enthält.

CD.
1804-BO
PR.
€ 690,00
CL.
BO
DS.
Lampada led a sospensione in alluminio 17,3W - 3000K dotata nella parte superiore del paralume di un filtro con ioni d'argento per la purificazione dell'aria. Aluminum suspension led lamp 17,3W - 3000K equipped in the upper part of the lampshade with a filter containing silver ions for air purification. Lampe led à suspension 17,3W - 3000K équipée dans la partie supérieure de l'abat-jour d'un filtre contenant des ions argent pour la purification de l'air. Lámpara led de suspensión 17,3W - 3000K equipada en la parte superior de la pantalla con un filtro que contiene iones de plata para la purificación del aire. LED-Hängelampe 17,3W - 3000K, ausgestattet im oberen Teil des Lampenschirms mit einem Filter, der Silberionen zur Luftreinigung enthält.

AIR PURIFICATION TECHNOLOGY

I_ Il calore della lampada riscalda l'aria nella parte superiore generando un moto convettivo. L'aria così riscaldata passa attraverso un filtro realizzato in maglia di alluminio, galvanizzato e trattato con ioni d'argento, purificandosi.

EN_ The lamp heats the air in the upper part, generating a convective motion. The heated air passes through a filter made of galvanized aluminum mesh, treated with silver ions, purifying itself.

F_ La chaleur d'une lampe réchauffe l'air dans la partie supérieure, en créant un mouvement convectif. Cet air chaud est purifié en passant à travers un filtre en maille d'aluminium galvanisé et traité aux ions d'argent.

E_ La lámpara calienta el aire en la parte superior, generando un movimiento convectivo. El aire caliente pasa a través de un filtro de malla de aluminio galvanizado, tratado con iones de plata, purificándose.

D_ Die Wärme der Lampe erhitzt die Luft im oberen Bereich und erzeugt eine Konvektionsbewegung. Die so erwärmte Luft strömt durch einen Filter aus galvanisiertem Aluminiumgewebe, das mit Silberionen behandelt wurde, und wird so gereinigt.

- 1** I_Filtro di purificazione dell'aria.
EN_Air purification filter.
F_Filtre de purification de l'air.
D_Luftreinigungsfilter.
E_Filtro de purificación del aire.

- 2** I_Corpo illuminante LED.
EN_LED element.
F_Corps d'éclairage à LED.
D_LED-Leuchtkörper.
E_Cuerpo de iluminación LED.

- 3** I_Flusso dell'aria.
EN_Air flow.
F_Flux d'air.
D_Luftstrom.
E_Flujo de aire

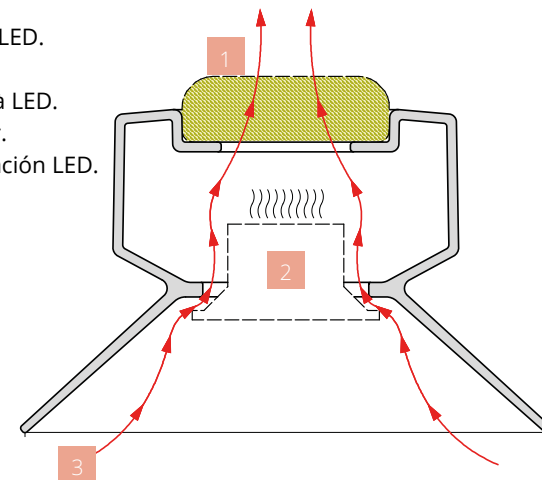

CONDIZIONI GENERALI DI VENDITA

1. Il presente listino annulla e sostituisce i precedenti e non costituisce offerta.
2. I prezzi dei prodotti possono essere variati dalla venditrice in qualsiasi momento senza preavviso; tutti i prezzi non sono comprensivi di montaggio.
3. La venditrice si riserva la facoltà di modificare, a proprio insindacabile giudizio e senza preavviso alcuno, i materiali costruttivi, le caratteristiche tecniche ed estetiche, nonché le dimensioni dei prodotti.
4. Le immagini dei prodotti sono puramente indicative.
5. La vendita è regolata, oltre che dalle condizioni particolari di volta a volta pattuite, dalle presenti condizioni generali, che si reputano conosciute dall'acquirente; eventuali clausole derogatorie a quanto previsto nelle presenti condizioni generali di vendita devono risultare per iscritto.
6. Le proposte d'acquisto e/o gli ordini dell'acquirente sono condizionati all'accettazione espressa o all'inizio dell'esecuzione del contratto da parte della venditrice, nei casi in cui ciò sia consentito. Qualsiasi successiva modifica al contratto di vendita non sarà valida e vincolante ove non risulti da atto scritto e sottoscritto dalla parte nei cui confronti tale modifica viene invocata.
7. Conformemente all'articolo 1510 codice civile, la consegna dei beni venduti si ha con la rimessione degli stessi al vettore o allo spedizioniere, sicché i beni stessi viaggiano a rischio e pericolo dell'acquirente; ciò vale anche nei casi in cui la merce venga venduta franco arrivo all'indirizzo dell'acquirente. Ogni eventuale richiesta, reclamo e/o azione relativi alla spedizione o al trasporto della merce dovrà essere promossa dall'acquirente direttamente nei confronti dello spedizioniere o del vettore. Ogni eventuale danno, perdita o avaria dei beni venduti dipendente dalla spedizione o dal trasporto dei medesimi non esonera l'acquirente dal pagamento del prezzo convenuto.
8. Il termine di consegna è indicativo e non tassativo; lo stesso potrà essere ritardato senza alcun obbligo di indennizzo o risarcimento di eventuali danni diretti o indiretti subiti dall'acquirente per la ritardata consegna e senza che ciò possa comunque comportare la risoluzione del contratto di vendita per inadempimento della venditrice.
9. Fatti salvi i casi di forza maggiore, in caso di scioperi ed in tutti gli altri casi che impediscano temporaneamente alla venditrice di regolarmente adempiere al contratto di vendita, è fatto salvo il diritto della medesima venditrice di recedere dal contratto, senza che l'acquirente sia legittimato ad eventuali pretese di danno, fatta salva nell'ipotesi di recesso la restituzione di quanto eventualmente versato a titolo di acconto.
10. Il pagamento del prezzo di vendita dei prodotti dovrà avvenire presso la sede della venditrice. In caso di pagamento ritardato, l'acquirente sarà automaticamente costituito in mora e sarà tenuto al pagamento degli interessi nella misura e con la decorrenza stabilita dal D.Lgs. 231/2002 per i ritardi di pagamento nelle transazioni commerciali.
11. La venditrice non risponde degli eventuali vizi dei prodotti conosciuti o conoscibili da parte dell'acquirente, che non abbia immediatamente respinto la merce. Le contestazioni od i reclami sulle quantità dei prodotti devono essere segnalate all'atto della consegna, con annotazione sul relativo documento di trasporto. La eventuale sostituzione del prodotto non significa accettazione della contestazione o del reclamo. L'accredito all'acquirente verrà fatto solo dopo la restituzione dei prodotti difettosi ed a condizione che sia stata riconosciuta o altrimenti accertata la responsabilità dalla venditrice.
12. I disegni, i modelli, i grafici e le altre informazioni tecniche dei prodotti oggetto di vendita, così come i campioni, i cataloghi, le fotografie e materiali simili, rimangono sempre di proprietà intellettuale della venditrice e non possono pertanto essere copiati, né trasmessi ad altri, né utilizzati in altro modo.
13. Le somme versate a titolo di caparra confirmatoria potranno essere ritenute dalla venditrice in caso di revoca dell'ordine e/o in ogni altro caso di inadempimento dell'acquirente che giustifichi il recesso della venditrice, salvo il diritto di chiedere l'adempimento del contratto e salvo altresì il diritto di chiedere il risarcimento del maggiore danno. Per converso, nel caso di adempimento da parte dell'acquirente dei propri obblighi contrattuali, le somme da questi versate a titolo di caparra confirmatoria saranno imputate al pagamento del prezzo; le stesse, così come gli eventuali acconti, saranno comunque infruttifere di interessi.
14. L'eventuale tolleranza di una delle parti di comportamenti dell'altra posti in essere in violazione delle clausole che regolano la vendita non costituisce rinuncia ai diritti derivanti dalle clausole violate né al diritto di esigere l'esatto adempimento di tutti i termini e condizioni previsti dal contratto di vendita.
15. La venditrice mantiene la proprietà dei prodotti consegnati fino al completo pagamento del prezzo indicato in fattura. Fino a tale data i prodotti consegnati sono considerati solo come depositati presso l'acquirente. Quest'ultimo si accolla quindi il rischio di danni che i prodotti depositati possano subire imputabili a qualsiasi causa.
16. L'acquirente è invitato a prestare particolare attenzione sul fatto che non tutti i prodotti riportati nel presente listino sono compatibili con il mercato statunitense o con quello canadese. Conseguentemente, qualora l'acquirente intendesse utilizzare o esportare detti prodotti negli Stati Uniti d'America e/o, in ogni caso, in qualsiasi altro paese extra UE, è obbligato a preventivamente contattare l'ufficio commerciale della venditrice per avere la conferma che il prodotto interessato risponda a tutti i requisiti tecnici ed agli standard legali previsti a tutela dei consumatori finali del mercato di destino. La venditrice declina ogni responsabilità conseguente alle iniziative assunte dall'acquirente senza essere stata preventivamente informata ed indipendentemente dall'eventuale autorizzazione scritta della venditrice all'esportazione e/o all'uso del prodotto in un paese extra UE.
17. La venditrice garantisce la conformità dei prodotti alle specifiche indicate nella conferma d'ordine, fatte salve le tolleranze ritenute accettabili dalla produzione industriale.
18. L'acquirente è tenuto ad informare i propri clienti e/o gli utilizzatori finali sulle caratteristiche del prodotto al fine di ridurre al minimo il rischio di un uso improprio che potrebbe esporre la venditrice a possibili ragioni di danno. In difetto di tale attività informativa preventiva, l'acquirente esonera espressamente la venditrice da qualsiasi ipotetica responsabilità.
19. La venditrice non garantisce l'idoneità dei prodotti per scopi particolari e/o usi speciali, salvo specifica richiesta dell'acquirente espressamente accettata per iscritto dalla venditrice e riportata nella relativa conferma d'ordine; l'acquirente deve assicurarsi che gli eventuali standard specifici e/o requisiti legali richiesti siano specificati nella relativa conferma d'ordine della venditrice.
20. Le informazioni della venditrice sull'idoneità specifica dei prodotti sono puramente indicative.
21. Eventuali attività di assistenza e/o calcolo effettuate dalla venditrice sui prodotti, sono da considerarsi puramente indicative e non vincolanti costituendo un mero suggerimento sul posizionamento di massima dei prodotti, ogni dato suggerito deve essere in ogni caso verificato compiutamente dall'acquirente; va da sé che trattandosi comunque di meri suggerimenti non vincolanti, la venditrice non si assume alcuna responsabilità sui risultati di tali attività.
22. Poiché le applicazioni dei prodotti fatte dall'acquirente sono fuori dal controllo della venditrice, quest'ultima non è responsabile per l'uso effettivo dei prodotti; la venditrice non è responsabile per eventuali danni e/o perdite derivanti dall'applicazione non corretta o insolita dei prodotti.
23. L'annullamento di un ordine da parte dell'acquirente è consentito solo in casi eccezionali e previo consenso scritto da parte della venditrice.
24. Nel caso di ordini di prodotti e/o colori fuori standard l'acquirente deve acquistare l'intera produzione effettuata appositamente.
25. Salvo diversa pattuizione e salvo il caso di dolo, la responsabilità della venditrice per i prodotti venduti è limitata ad un importo pari a tre volte il valore della conferma d'ordine, anche in caso di colpa grave.
26. Tutte le controversie che dovessero insorgere in relazione alla vendita, suoi atti modificativi ed esecutivi, comprese quelle inerenti alla validità, efficacia, interpretazione, esecuzione e risoluzione del contratto, saranno devolute alla competenza esclusiva del Foro di Milano.
27. In ogni caso, prima di procedere all'acquisto dei prodotti è necessario consultare le condizioni di vendita, le caratteristiche tecniche e le seguenti ulteriori:

AVVERTENZE

- prima di procedere all'installazione dei prodotti è necessario verificare la portanza della parete/pavimento/superficie su cui verranno collocati i prodotti assicurandosi che siano idonei al tipo di utenza e/o di utilizzo a cui sono destinati;
- i prodotti non sono idonei all'uso da parte di bambini;
- i prodotti non sono idonei ad essere utilizzati in ambienti esterni;
- i prodotti applicati a parete/pavimento/superficie prevedono l'installazione con dispositivi di ancoraggio che non compaiono nelle illustrazioni del catalogo;
- i prodotti devono essere montati e/o installati esclusivamente da personale tecnico competente utilizzando strumenti ed attrezzi adatti allo scopo;
- prima di procedere al montaggio ed all'installazione dei prodotti è necessario leggere attentamente le istruzioni allegate ai prodotti, prestando particolare attenzione sia alle avvertenze che ai disegni esplicativi; qualora le istruzioni non fossero allegate contattare l'ufficio tecnico della venditrice;
- per fissare i prodotti a parete/pavimento/superfici, è necessario utilizzare dei dispositivi di fissaggio adeguati ed in grado di resistere alle forze generate; in ogni caso è necessario utilizzare degli elementi di sostegno idonei a reggere ogni singola struttura;
- in caso di installazione non corretta e/o in caso di superamento dei carichi massimi indicati nel presente listino e/o nelle istruzioni allegate ai singoli prodotti, si potrebbe creare una situazione di pericolo, i prodotti potrebbero collassare, cadere e causare danni a cose e/o persone: non superare mai i carichi evidenziati;
- in caso di dubbi sulle modalità di installazione e/o sulla portanza della parete/pavimento/superficie su cui verrà collocato il prodotto non procedere alla installazione;
- attenersi alle istruzioni e alle composizioni riportate nel presente listino; per composizioni differenti e/o per ulteriori informazioni sui prodotti o sulle modalità di installazione degli stessi contattate l'ufficio tecnico della venditrice.
- leggere differenze di colore fra una partita e l'altra sono da considerarsi normali attese le tolleranze ritenute accettabili per la produzione industriale;
- Il testo facente fede è esclusivamente quello in lingua italiana, le traduzioni hanno la finalità esclusiva di semplificarne la lettura.

GENERAL TERMS OF SALE

1. This price list cancels and replaces the previous ones and is not a proposal.
2. The product prices may be changed by the vendor at any moment without prior notice; all prices are not inclusive of installation.
3. The vendor reserves the right to alter the construction materials, the technical and visual characteristics and also the dimensions of the products, at its own unquestionable discretion and without any prior notice.
4. Product images are purely indicative.
5. In addition to the specific terms agreed each time, sale is governed by these general terms, which are considered to be known by the purchaser; any clauses derogating from these general terms of sale must be in writing.
6. The purchaser's purchase proposals and/or orders are conditional upon the vendor expressly accepting or starting fulfilment of the agreement, in cases where this is permitted. Any subsequent amendment to the sales agreement will not be valid and binding unless entered in a written document signed by the party being asked to accept this amendment.
7. In compliance with article 1510 of the Italian Civil Code, delivery of the goods sold is with remittance thereon to the carrier or forwarder, so that the goods travel at the purchaser's risk and danger; this also applies in cases where the goods are sold free to the purchaser's address. Any other request, complaint and/or action relating to shipment or transport of the goods must be brought by the purchaser directly against the forwarder or the carrier. Any damage, loss or breakage of the goods sold which is attributable to shipment or transport thereof will not exempt the purchaser from liability for payment of the agreed price.
8. The delivery time is indicative and not binding; it may be delayed without any obligation of indemnity or compensation of any direct or consequential damages suffered by the purchaser as a result of late delivery and without this leading to termination of the sales agreement due to the vendor's non-fulfilment.
9. With the exception of cases of force majeure, in the case of strikes and all other cases which temporarily prevent the vendor from fulfilling the sales agreement properly, the vendor is entitled to withdraw from the agreement, without the purchaser being entitled to claim any damages, except for the repayment in the case of withdrawal, of any amount paid as an advance.
10. Payment of the sale price of the products must be made at the vendor's registered office. In the case of late payment, the purchaser will automatically be placed in arrears and will be required to pay interest in the amount and from the time required by Legislative Decree 231/2002 for late payment in commercial transactions.
11. The vendor is not liable for any defects of the products known or knowable to the purchaser, who has not immediately refused to accept delivery of the goods. Disputes or complaints over the product quantities must be notified upon delivery, with noting on the relative transport document. Replacement of the product does not signify acceptance of the claim or complaint. The purchaser will only be credited the amount after the faulty products have been returned and provided that the vendor's liability has been recognised or otherwise ascertained.
12. The drawings, models, graphs and other technical information on the products being sold, and also samples, catalogues, photographs and similar materials, always remain the intellectual property of the vendor and may not be copied, or transmitted to others, or used in any other way.
13. The amounts paid by way of a deposit may be withheld by the vendor if the order is cancelled and/or in all other cases of non-fulfilment by the purchaser which justifies the vendor's withdrawal, without prejudice to the right to request fulfilment of the agreement and also the right to demand compensation of greater damages. In contrast, if the purchaser fulfils its contractual obligations, the amounts paid by way of deposit will be allocated to payment of the price; said amounts, and all other advances, will be non-interest-bearing.
14. Any tolerance by one of the parties of the other's conduct which breaches the clauses governing sale does not constitute waiving of the rights deriving from the breached clauses nor the right to demand precise fulfilment of all the terms and conditions contained in the sales agreement.
15. The vendor maintains ownership of the products until complete payment of the price indicated on the invoice. Up until that date, the products delivered are considered as only held in deposit by the purchaser. The latter therefore accepts the risk of damages to the products deposited attributable to any cause.
16. The purchaser is invited to pay particular attention to the fact that not all products on the price list are compatible with the US or Canadian markets. Consequently, if intending to use or export said products into the USA and/or, in any case, into any other non-EU country, the purchaser is required to contact the vendor's sales office beforehand for confirmation that the product concerned satisfies all technical requirements and legal standards protecting final consumers on the market of destination. The vendor declines all liability consequent upon initiatives taken by the purchaser without it having been informed beforehand and irrespective of any written authorisation of the vendor for exportation to and/or use of the product in a non-EU country.
17. The purchaser is required to inform its own customers and/or final users of the product characteristics, in order to reduce to a minimum the risk of improper use which could expose the vendor to possible claims of damage. In the case of failure to provide this prior information, the purchaser expressly exempts the vendor from any hypothetical liability.
18. The seller guarantees the conformity of the products to the specifications indicated in the order confirmation, except for the tolerances considered acceptable in industrial production.
19. The seller does not guarantee the suitability of the products for particular purposes and/or special uses, unless specifically requested by the buyer and expressly accepted in writing by the seller with a statement in the relative order confirmation; the buyer must ensure that any specific standards and/or legal requirements are specified in the relative order confirmation of the seller.
20. The seller's information regarding specific suitability of the products is purely indicative.
21. Any eventual consulting and/or design activity and/or calculation carried out by the seller pertaining products is to be considered purely indicative and represents a simple suggestion concerning products' generic positioning, hence not binding. Each suggested fact must be fully verified by the buyer; the seller assumes no responsibility for the results of such activities.
22. Since the applications of the products made by the buyer are beyond the seller's control, the seller is not responsible for the actual use of the products; the seller is not responsible for any damage and/or loss resulting from incorrect or unusual application of the products.
23. Cancellation of an order by the buyer is permitted only in exceptional cases and subject to prior written consent from the seller.
24. In case of orders containing non-standard products and/or colors, the buyer must purchase the entire production carried out specifically for this purpose.
25. Unless otherwise agreed and unless in case of fraud, the seller's liability for the products sold is limited to an amount equal to three times the value of the order confirmation, even in case of severe guilt.
26. Milan Court will be the sole court of competent jurisdiction for all disputes which may arise in relation to sale and any actions of amendment and enforcement thereof, including those relating to the validity, effectiveness, interpretation, fulfilment and termination of the agreement.
27. In any case, before purchasing the products, it is necessary to consult the terms of sale, technical characteristics and furthermore the following:

WARNINGS

- Before installing the products, check the bearing capacity of the wall/floor/surface on which the products will be positioned, ensuring they are suitable for the intended type of user/use.
- The products are not suitable for use by children.
- The products are not suitable for use outside.
- If the products are applied to the wall/floor/surface, they must be installed with anchoring devices (not shown in the catalogue).
- The products must be assembled and/or installed exclusively by skilled technical personnel, using instruments and tools appropriate for this purpose.
- Carefully read the instructions enclosed with the product before proceeding with assembly and installation, paying particular attention to the warnings and to the explanatory drawings; if the instructions are not attached, contact the vendor's technical office.
- Suitable attachment devices must be used to attach the products to the wall/floor/surfaces, which are strong enough to resist the forces generated; in any case, suitable supporting elements to support each individual element must be used.
- In the case of incorrect installation and/or weights exceeding the maximum loads indicated on this price list and/or the instructions attached to the individual products, a situation of danger could be created, the products could collapse, fall and cause damage to people and/or things: never exceed the loads indicated.
- Do not install the product in the case of any doubts over the methods of installation and/or bearing capacity of the wall/floor/surface on which the product is to be positioned.
- Comply with the instructions and compositions shown on this price list; for different compositions and/or further information on the products or installation methods, contact the vendor's technical office.
- Slight color differences between one lot and another have to be considered normal, within usual tolerances usually accepted for industrial productions.
- The authentic text is only in Italian, the translation has the mere purpose of simplifying the reading.

CONDITIONS GÉNÉRALES DE VENTE

1. Le présent catalogue des prix annule et remplace les précédents et ne constitue pas une offre.
2. Les prix des produits peuvent être changés par la venderesse à tout moment sans préavis; aucun prix ne comprend le montage.
3. La venderesse se réserve le droit de modifier, selon sa décision sans appel et sans aucun préavis, les matériaux servant à la construction, les caractéristiques techniques et esthétiques ainsi que les dimensions des produits.
4. Les images des produits sont fournies à titre purement indicatif.
5. La vente est réglemtée, en plus des conditions particulières convenues à chaque fois, par les présentes conditions générales, qui sont considérées comme connues par l'acheteur; d'éventuelles clauses dérogatoires aux dispositions des présentes conditions générales de vente doivent être mises par écrit.
6. Les offres d'achat et/ou commandes de l'acheteur sont soumises à l'acceptation explicite ou au début de l'exécution du contrat par la venderesse, dans les cas où cela est possible. Aucune modification suivante au contrat de vente ne sera valide et contraignante sans acte écrit et signé par la partie contre laquelle cette modification est invoquée.
7. Conformément à l'article 1510 du code civil, la livraison des biens vendus se fait par la remise de ceux-ci au transporteur ou à l'expéditionnaire, de sorte que les dits biens voyagent aux risques et périls de l'acheteur; cette règle vaut aussi dans les cas où la marchandise est vendue franco adresse de l'acheteur. Toute éventuelle demande, réclamation et/ou action relative à l'expédition ou au transport de la marchandise devra être faite par l'acheteur directement à l'expéditionnaire ou au transporteur. Les éventuels dommages, perte ou avarie des biens vendus dépendant de leur expédition ou du transport n'exonèrent pas l'acheteur du paiement du prix convenu.
8. La date de livraison est indicative et non péremptoire; elle pourra être retardée sans aucune obligation d'indemnisation ou de dédommagement d'éventuels dommages directs ou indirects subis par l'acheteur à cause de la livraison retardée et sans que cela puisse de toute manière comporter la résiliation du contrat de vente pour inexécution de la venderesse.
9. Sauf les cas de force majeure, en cas de grèves et dans tous les autres cas qui empêchent temporairement la venderesse de remplir normalement le contrat de vente, la venderesse a le droit de résilier le contrat, sans pour autant que ce fait légitime l'acheteur à d'éventuelles prétentions de dommage, sauf, dans l'hypothèse de résiliation, la restitution des sommes éventuellement versées à titre d'acompte.
10. Le paiement du prix de vente des produits devra se faire au siège de la venderesse. En cas de paiement en retard, l'acheteur sera automatiquement mis en demeure et sera tenu de payer des intérêts au taux et dans les délais établis par le décret de loi 231/2002 régissant les retards de paiement dans les transactions commerciales.
11. La venderesse n'est pas responsable des éventuels vices des produits connus ou que l'acheteur aurait pu connaître s'il n'a pas immédiatement refusé la marchandise. Les contestations ou les réclamations sur les quantités des produits doivent être signalées au moment de la livraison, au moyen d'une note écrite sur le document de transport. L'éventuel remplacement du produit ne signifie pas l'acceptation de la contestation ou de la réclamation. Le remboursement de l'acheteur sera fait uniquement après la restitution des produits défectueux et à condition qu'il ait été reconnue ou autrement établie la responsabilité de la venderesse.
12. Les dessins, les modèles, les graphiques et les autres informations techniques sur les produits objet de la vente, ainsi que les échantillons, les catalogues, les photos et tout le matériel similaire demeurent toujours la propriété intellectuelle de la venderesse et ne peuvent par conséquent pas être copiés, ni transmis à des tiers, ni utilisés d'aucune autre manière.
13. Les sommes versées à titre d'arrhes de confirmation pourront être retenues par la venderesse en cas de révocation de la commande et/ou dans tout autre cas d'inexécution de l'acheteur justifiant la résiliation par la venderesse, sauf le droit de demander l'exécution du contrat et aussi sauf le droit de demander le dédommagement du dommage supérieur. Au contraire, dans le cas d'exécution par l'acheteur de ses propres obligations contractuelles, les sommes qu'il aura versées à titre d'arrhes de confirmation seront imputées au paiement du prix; celles-ci, ainsi que les éventuels acomptes, ne produiront pas d'intérêts.
14. L'éventuelle tolérance par une des parties des comportements de l'autre en violation des clauses qui régissent la vente ne constitue pas une renonciation aux droits découlant des clauses violées ni au droit d'exiger l'exécution exacte de tous les termes et conditions prévus par le contrat de vente.
15. La venderesse garde la propriété des produits livrés jusqu'au paiement total du prix indiqué dans la facture. Jusqu'à cette date, les produits livrés sont considérés comme seulement déposés chez l'acheteur. Ce dernier prend donc en charge le risque des dommages que les produits déposés pourraient subir qu'ils soient imputables à n'importe quelle cause.
16. L'acheteur est invité à faire particulièrement attention au fait que tous les produits indiqués dans le présent catalogue des prix ne sont pas nécessairement compatibles avec les marchés américain ou canadien. Par conséquent, si l'acheteur a l'intention d'utiliser ou d'exporter les dits produits aux États-Unis et, dans tous les cas, dans n'importe quel autre pays extra UE, il doit préalablement contacter le bureau commercial de la venderesse pour avoir la confirmation que le produit concerné remplit toutes les exigences techniques et est conforme aux standards légaux prévus pour la protection des consommateurs finaux du marché de destination. La venderesse décline toute responsabilité pour des initiatives prises par l'acheteur dont elle n'a pas été préalablement informée et indépendamment de l'éventuelle autorisation écrite de la venderesse pour l'exportation et ou l'emploi du produit dans un pays extra UE.
17. L'acheteur est tenu d'informer ses propres clients et/ou les utilisateurs finaux des caractéristiques du produit afin de réduire au minimum le risque d'emploi impropre qui pourrait exposer la venderesse à d'éventuelles demandes de dédommagement. À défaut de cette activité d'information préventive, l'acheteur exonère expressément la venderesse de toute hypothétique responsabilité.
18. Le vendeur garantit la conformité des produits avec les spécifications indiquées dans la confirmation de la commande, sous réserve des tolérances considérées acceptables pour la production industrielle.
19. Le vendeur ne garantit pas que les produits sont appropriés pour des occasions particulières et/ou des usages spéciaux, sous réserve de demande spécifique de l'acheteur expressément acceptée par écrit par le vendeur et indiquée dans la confirmation de la commande; l'acheteur doit s'assurer que les normes spécifiques éventuelles et/ou les conditions légales exigées soient spécifiées dans la confirmation de la commande de la part du vendeur.
20. Les informations du vendeur sur la pertinence spécifique des produits sont purement indicatives.
21. Toute activité d'assistance et/ou calcul effectuée par le vendeur sur les produits est à considérer comme purement indicative et non contraignante en s'agissant d'un simple conseil sur le positionnement des produits, chaque donnée doit être dûment vérifiée par l'acheteur; il est évident qu'en s'agissant de simples suggestions non contraignantes, le vendeur n'assume aucune responsabilité quant aux résultats de ces activités.
22. Etant donné que les utilisations des produits faites par l'acheteur sont en dehors du contrôle du vendeur, ce dernier n'est pas responsable pour l'utilisation effective des produits; le vendeur n'est pas responsable pour d'éventuels dommages et/ou pertes dus à l'utilisation non correcte ou inhabituelle des produits.
23. L'annulation d'une commande de la part de l'acheteur n'est autorisée qu'en des cas exceptionnels et avec l'accord écrit préalable du vendeur.
24. En cas de commandes de produits et/ou couleurs hors norme l'acheteur est tenu à acheter toute la production effectuée expressément pour lui.
25. Sauf convention contraire et sauf en cas de fraude, la responsabilité du vendeur pour les produits vendus est limitée à un montant égal au triple de la valeur de la confirmation de la commande, même en cas de faute grave.
26. Toutes les controverses qui devraient surgir relatives à la vente, à ses actes de modification et d'exécution, y compris celles concernant la validité, l'efficacité, l'interprétation, l'exécution et la résiliation du contrat, seront du ressort exclusif du Tribunal de Milan.
27. De toute manière, avant de procéder à l'achat des produits, il faut consulter les conditions de vente, les caractéristiques techniques et les autres suivantes:

MISES EN GARDE

- avant de procéder à l'installation des produits, il faut vérifier la portée maximum des murs/ sol/surfaces sur lesquelles les produits seront placés en s'assurant qu'ils soient adaptés au type d'usage et/ou d'utilisation auquel ils sont destinés;
- les produits ne doivent pas être utilisés par les enfants;
- les produits ne doivent pas être utilisés à l'extérieur des bâtiments;
- les produits appliqués aux murs/ sol/surfaces comportent l'installation avec des dispositifs d'ancrage qui ne sont pas montrés dans les illustrations du catalogue;
- les produits doivent être montés et/ou installés exclusivement par du personnel technique compétent en utilisant des instruments et outils prévus à cet effet;
- avant de procéder au montage et à l'installation des produits, il faut lire attentivement les instructions jointes aux produits, en faisant particulièrement attention tant aux instructions qu'aux dessins explicatifs; si les instructions ne sont pas jointes, contacter le bureau technique de la venderesse;
- pour fixer les produits aux murs/sol/surfaces, il faut utiliser des dispositifs de fixation adéquats et en mesure de résister aux forces générées; dans tous les cas il est nécessaire d'utiliser des éléments de soutien adéquats à supporter chaque structure en particulier;
- en cas d'installation non correcte et/ou en cas de dépassement des charges maximales indiquées dans le présent catalogue des prix et/ou dans les instructions jointes à chaque produit, une situation de danger pourrait se créer, les produits pourraient s'effondrer, céder, tomber et causer des dommages aux choses et/ou aux personnes; jamais dépasser les charges indiquées;
- en cas de doutes sur les modes d'installation et/ou sur le maximum de portée des murs/ sol/surface sur lesquels sera placé le produit, ne pas procéder à l'installation;
- s'en tenir aux instructions et aux compositions indiquées dans le présent catalogue des prix; pour des compositions différentes et/ou pour toute information supplémentaire sur les produits ou sur les modes d'installation de ceux-ci, contacter le bureau technique de la venderesse;
- légères différences de couleur entre un lot et l'autre doivent être considérées comme étant normales si dans le limite des tolérances jugées acceptables pour la production industrielle;
- le texte de référence est seulement celui en italien, les traductions ont le seul but de simplifier la lecture.

CONDICIONES DE VENTA

1. Esta lista de precios anula y sustituye las anteriores y no es una oferta.
2. El vendedor puede cambiar los precios de los productos en cualquier momento sin previo aviso; ninguno de los precios incluye el montaje.
3. El vendedor se reserva el derecho de modificar, a su entera discreción y sin previo aviso, los materiales de construcción, las características técnicas y estéticas así como también las dimensiones de los productos.
4. Las imágenes de los productos son meramente ilustrativas.
5. La venta se rige no sólo por las condiciones especiales acordadas caso por caso, sino también por las presentes condiciones generales, que el comprador ha de conocer; posibles cláusulas de exención a lo dispuesto en las presentes condiciones generales de venta deben figurar por escrito.
6. Las propuestas de compra y/o pedidos del comprador dependen de la aceptación o del inicio del contrato por parte del vendedor, en los casos en que esto esté permitido. Cualquier modificación posterior al contrato de venta no será válida ni vinculante si no figura en un contrato escrito, firmado por la parte en relación a la cual se pide dicha modificación.
7. En conformidad con el artículo 1510 del Código Civil, la entrega de los bienes vendidos se considera a partir de la remisión de los mismos al transportista o al agente de transporte, es decir que los bienes viajan a riesgo y peligro del comprador; esto vale también en los casos en los cuales la mercancía haya sido vendida con el transporte pagado hasta la sede del comprador. Cualquier posible petición, queja y/o acción relacionada con el envío o transporte de mercancías deberá ser efectuada por el comprador directamente contra el transportista o agente de transportes. Cualquier posible daño, pérdida o rotura de los bienes vendidos debidos a la expedición o al transporte de los mismos no exime al comprador de pagar el precio convenido.
8. El plazo de entrega es indicativo y no perentorio; el mismo podrá retrasarse sin ninguna obligación de indemnización ni compensación de los daños directos o indirectos sufridos por el comprador por la entrega tardía y sin que esto pueda llevar a la terminación del contrato de venta por incumplimiento del vendedor.
9. Excepto en los casos de fuerza mayor, en caso de huelgas y en los demás casos que impidan temporalmente al vendedor cumplir normalmente con el contrato de venta, el vendedor tendrá el derecho de rescindir el contrato, sin que el comprador pueda presentar ninguna reclamación por daños y perjuicios, salvo en el caso de cancelación, la devolución de lo pagado por adelantado.
10. El pago del precio de venta de los productos debe llevarse a cabo en las instalaciones del vendedor. En caso de demora en el pago, el comprador estará automáticamente en mora y deberá pagar intereses en la medida y con la fecha establecida por el Decreto Legislativo. 231/2002 de la morosidad en las transacciones comerciales
11. El vendedor no se hace responsable por posibles defectos de los productos identificados o identificables por parte del comprador, que no haya rechazado inmediatamente. Cualquier disputa o queja sobre las cantidades de productos deben ser indicadas en el momento de la entrega, con la anotación en el documento de transporte correspondiente. La posible sustitución del producto no implica la aceptación de la objeción o queja. El pago al comprador se realizará sólo una vez efectuada la devolución de los productos defectuosos y siempre que se haya reconocido o comprobado la responsabilidad del vendedor.
12. Los dibujos, modelos, diagramas y otra información técnica de los productos vendidos, así como las muestras, catálogos, fotografías y otros materiales similares, siguen siendo de propiedad intelectual del vendedor y no pueden ser copiados ni transmitidos a otras personas ni utilizarse de otro modo.
13. Las sumas abonadas en concepto de señal confirmatoria podrán ser retenidas por el vendedor en caso de revocación del pedido y/o ante cualquier otro caso de incumplimiento por parte del comprador que justifique la retirada del vendedor, salvo el derecho a exigir el cumplimiento del contrato y también el derecho a reclamar indemnización por daños y perjuicios adicionales. Por el contrario, en el caso de cumplimiento por parte del comprador de sus obligaciones contractuales, las cantidades pagadas en concepto de señal confirmatoria serán consideradas con el pago del precio; las mismas, así como también los pagos iniciales, serán de todos modos sin intereses.
14. Cualquier tolerancia de una de las partes a conductas iniciadas en violación de las disposiciones que rigen la venta no constituirá una renuncia a derechos que se deriven de las disposiciones violadas o el derecho a exigir el estricto cumplimiento de todos los términos y condiciones establecidos en contrato de venta.
15. El vendedor conserva la propiedad de los bienes entregados hasta el pago total del precio indicado en la factura. Hasta esa fecha, los productos entregados han de considerarse sólo como bienes depositados en la sede del comprador. Por lo tanto, este último se asume el riesgo por los daños que los mismos puedan sufrir debidos a cualquier causa.
16. El comprador ha de prestar especial atención al hecho de que no todos los productos que figuran en este catálogo son compatibles con el mercado de los EE.UU. o de Canadá. Por lo tanto, si el comprador tiene la intención de utilizar o exportar dichos productos en los Estados Unidos de América y/o, de todos modos, en cualquier otro país fuera de la UE, debe antes y imperativamente ponerse en contacto con la oficina de ventas del vendedor para confirmar que el producto en cuestión cumpla con todos los requisitos técnicos y las normas establecidas en la legislación para proteger a los consumidores en el mercado de destino. El vendedor no se asume ninguna responsabilidad con respecto a las iniciativas adoptadas por el comprador, sin haber sido informado previamente y independientemente de la posible autorización por escrito por parte del vendedor a la exportación y/o uso del producto en un país fuera de la UE.
17. El comprador está obligado a informar a sus clientes y/o usuarios finales de las características del producto para reducir al mínimo el riesgo de mal uso que podría exponer al vendedor a posibles motivos de daño. En ausencia de dicha actividad de información preventiva, el comprador libera expresamente al vendedor de cualquier responsabilidad hipotética.
18. El vendedor garantiza la conformidad de los productos a las especificaciones mencionadas en la confirmación del pedido, excepto las tolerancias que se consideren aceptables para la producción industrial.
19. El vendedor no garantiza la idoneidad de los productos para fines especiales y/o usos específicos, a menos que el comprador no la haya pedido de forma específica y que el vendedor la haya aceptado expresamente por escrito constando en la correspondiente confirmación del pedido; el comprador debe comprobar que las posibles normas específicas y/o requisitos legales exigidos consten en la correspondiente confirmación del pedido del vendedor
20. La información que facilita el vendedor con respecto a la idoneidad específica de los productos es meramente indicativa.
21. . De haber una actividad de asesoramiento y/o cálculo realizada por el vendedor sobre los productos, se la deberá considerar solamente indicativa y no vinculante siendo una mera sugerencia sobre el posicionamiento general de los productos, en cualquier caso le incumbirá al comprador controlar detalladamente cada uno de los datos propuestos; es evidente que el vendedor por tratarse de meras sugerencias no vinculantes, no asume responsabilidad alguna con respecto a los resultados de dicha actividad.
22. Puesto que el vendedor no puede controlar cómo el comprador emplea el producto, el vendedor no se hace responsable por el uso concreto de los productos; el vendedor no se hace responsable por los posibles daños y/o perjuicios debidos al uso incorrecto o extraño de los productos.
23. El comprador podrá cancelar un pedido sólo en casos excepcionales y previo consentimiento expreso por escrito por parte del vendedor.
24. En el caso de pedidos de productos y/o colores no estándar, el comprador deberá comprar toda la producción realizada específicamente.
25. Salvo acuerdo contrario y salvo el caso de dolo, la responsabilidad del vendedor por los productos vendidos se limita a un importe igual a tres veces el valor de la confirmación del pedido, también si hubiera culpa grave.
26. Todas las controversias que pudiesen surgir en relación con la venta, documentos modificativos y ejecutivos, incluidas las relativas a la validez, eficacia, interpretación, ejecución y terminación del contrato, serán resueltas exclusivamente por el Tribunal competente de Milán.

27. De todos modos, antes de comprar los productos es necesario leer las condiciones de venta, las especificaciones técnicas y además las siguientes:

- ADVERTENCIAS:** - antes de instalar los productos es necesario controlar las características de la pared/piso/superficie en donde se colocarán dichos productos, asegurándose que sean adecuados al tipo de usuario y/o de uso final;
- los productos no son adecuados para ser utilizados por niños;
 - los productos no son adecuados para ser utilizados al aire libre;
 - los productos aplicados a la pared/piso/superficie prevén el uso de dispositivos de anclaje que no están ilustrados en el catálogo;
 - los productos deben ser montados y/o instalados exclusivamente por personal técnico cualificado utilizando los instrumentos y las herramientas específicas para dicho fin;
 - antes de montar y instalar los productos es necesario leer atentamente las instrucciones adjuntas a los productos, prestando especial atención tanto a las advertencias como a los diseños de explicación; si faltan las instrucciones, póngase en contacto con la oficina técnica del vendedor;
 - para fijar los productos a la pared/piso/superficies es necesario utilizar los dispositivos de sujeción adecuados capaces de resistir a las fuerzas generadas; se debe de todas formas utilizar elementos de soporte capaces de sostener cada una de las estructuras;
 - en caso de montaje incorrecto y/o en caso de un exceso de las cargas máximas especificadas en la presente lista y/o en las instrucciones adjuntas a cada producto, se podría crear una situación de peligro, los productos podrían colapsar, ceder, caer y causar daños a cosas y/o personas; no exceder nunca las cargas indicadas;
 - en caso de dudas acerca de cómo efectuar la instalación y/o de las características de la pared /piso/superficie sobre el cual será montado el producto, no lleve a cabo la instalación;
 - siga las instrucciones y elija las combinaciones que figuran en esta lista; para combinaciones diferentes y/o otras informaciones sobre los productos o sobre el modo de instalación de los mismos, póngase en contacto con la oficina técnica del vendedor.
 - Ligeras diferencias de color entre un lote y otro deben considerarse normales de cumplirse las tolerancias que se consideren aceptables para la producción industrial;
 - El texto auténtico es exclusivamente lo en idioma italiano, las traducciones tienen el único propósito de simplificar la lectura.

ALLGEMEINE VERKAUFSBEDINGUNGEN

1. Die vorliegende Preisliste hebt alle vorausgegangenen Listen auf, ersetzt sie und stellt kein Angebot dar.
2. Die Preise der Produkte können vom Verkäufer jederzeit ohne entsprechende Benachrichtigung geändert werden; keiner der Preise enthält die Montagekosten.
3. Der Verkäufer behält sich das Recht vor, nach seinem eigenen, unanfechtbaren Urteil und ohne entsprechende Benachrichtigung, Materialbeschaffenheit, technische Eigenschaften und Aussehen sowie die jeweiligen Abmessungen der Produkte zu ändern.
4. Die Produktbilder haben reinen Beispielcharakter.
5. Abgesehen von fallweise ausgehandelten Sonderkonditionen wird der Verkauf von den vorliegenden allgemeinen Bedingungen geregelt, von denen vorausgesetzt wird, dass der Käufer sie kennt; eventuell von den in den vorliegenden allgemeinen Verkaufsbedingungen abweichende Klauseln bedürfen jeweils der schriftlichen Form.
6. Die Kaufanbote und/oder Aufträge des Käufers bedürfen zuvor der ausdrücklichen Annahme bzw. in Fällen, in denen dies gestattet ist, des Beginns der Vertragserfüllung seitens des Verkäufers. Jegliche nachträgliche Änderung des Kaufvertrages ist nicht gültig und bindend, sofern nicht entsprechende schriftliche und jeweils von der Partei, die diese Änderung annehmen soll, unterzeichnete Unterlagen vorliegen.
7. Gemäß Art. 1510 Italienisches Bürgerliches Gesetzbuch (Codice Civile) findet die Lieferung der verkauften Waren bei deren Abgabe an den Transportunternehmer bzw. den Spediteur statt, so dass die Waren auf Risiko und Gefahr des Empfängers reisen; dies gilt auch in den Fällen, in denen die Ware frei Haus verkauft wird. Jeglicher Anspruch, Reklamation und/oder Klage betreffend die Lieferung oder den Transport der Waren muss vom Kunden direkt an den Transportunternehmer oder Spediteur gerichtet werden. Jeder eventuelle Schaden, Verlust oder Defekt der verkauften Waren, der durch den Versand bzw. Transport verursacht wurde, befreit den Käufer nicht von der Pflicht, den vereinbarten Kaufpreis zu zahlen.
8. Der Liefertermin gilt als ungefähre Angabe und ist nicht bindend; er kann sich verzögern, ohne dass eine Ersatz- oder Entschädigungspflicht für eventuelle direkte oder indirekte, vom Käufer infolge der verspäteten Lieferung erlittenen Schäden besteht und ohne dass dies zur Auflösung des Verkaufsvertrags aufgrund von Nichterfüllung des Verkäufers berechtigt.
9. Mit Ausnahme von Fällen höherer Gewalt, bei Streiks oder in allen anderen Fällen, durch die der Verkäufer vorübergehend außerstande ist, den Verkaufsvertrag ordnungsgemäß zu erfüllen, hat der Verkäufer das Recht, vom Vertrag zurückzutreten, ohne dass der Käufer berechtigt ist, eventuelle Schadensersatzansprüche zu stellen, mit Ausnahme der Rückzahlung einer allfälligen Anzahlung im Falle eines Rücktritts.
10. Die Zahlung des Verkaufspreises der Produkte hat direkt an den Sitz des Verkäufers zu erfolgen. Bei verspäteter Zahlung befindet sich der Käufer automatisch in Verzug und ist verpflichtet, Zinsen in dem von der Gesetzesverordnung 231/2002 über Zahlungsverzögerungen bei Handelsgeschäften festgelegten Umfang sowie mit den entsprechenden Fristen zu zahlen.
11. Der Verkäufer haftet nicht für eventuelle dem Käufer bekannte oder erkennbare Mängel, wenn dieser die Ware nicht umgehend zurückgewiesen hat. Beanstandungen oder Reklamationen in Bezug auf Produktmengen müssen jeweils bei Auslieferung gemeldet und auf den entsprechenden Transportunterlagen vermerkt werden. Der eventuelle Eratz des Produkts ist dabei nicht gleichbedeutend mit einer Akzeptanz der Beanstandung oder Reklamation. Die entsprechende Gutschrift für den Verkäufer erfolgt erst nach Rückgabe der mangelhaften Produkte und unter der Voraussetzung, dass die Verantwortung des Käufers anerkannt oder anderweitig festgestellt wurde.
12. Die Zeichnungen, Modelle, Darstellungen und anderen technischen Informationen über die Produkte, die den Gegenstand des Verkaufs bilden, ebenso wie die Muster, Kataloge, Photos und ähnlichen Materialien bleiben immer geistiges Eigentum des Verkäufers und dürfen daher weder kopiert, noch anderen überlassen oder in irgendeiner anderen Form genutzt werden.
13. Die als Anzahlung zur Bestätigung entrichteten Beträge können vom Verkäufer bei Annullierung des Auftrags und/oder in jedem anderen Fall einer Nichterfüllung seitens des Käufers einbehalten werden, die den Rücktritt des Verkäufers rechtfertigt, vorbehaltlich des Rechts, die Erfüllung des Vertrags zu verlangen und ebenso vorbehaltlich des Rechts, die Entschädigung eines darüber hinausgehenden Schadens zu verlangen. Umgekehrt werden im Fall der Erfüllung der Vertragsverpflichtungen seitens des Käufers die von diesem als Anzahlung zur Bestätigung entrichteten Beträge auf den Kaufpreis angerechnet; diese Beträge gelten auf jeden Fall, ebenso wie alle anderen Vorauszahlungen, als unverzichtlich.
14. Die eventuelle Hinnahme einer der Parteien von Verhaltensweisen der anderen Vertragspartei, durch die die Verkaufsbedingungen verletzt werden, stellt keinen Verzicht auf sich aus verletzten Klauseln ergebende Rechte dar, noch auf das Recht, die korrekte Erfüllung aller Fristen und Bedingungen zu verlangen, die vom Kaufvertrag vorgesehen sind.
15. Der Verkäufer behält das Eigentumsrecht an den gelieferten Produkten bis zur vollständigen Zahlung des jeweils in der Rechnung angegebenen Preises. Bis zu diesem Datum gelten die gelieferten Produkte nur als beim Verkäufer hinterlegt. Dieser letztere übernimmt daher auch das Risiko für Schäden, die an den hinterlegten Produkten aus irgendeinem Grund entstehen könnten.
16. Der Käufer wird aufgefordert, besondere Aufmerksamkeit darauf zu verwenden, dass nicht alle in dieser Preisliste angegebenen Produkte mit dem amerikanischen oder kanadischen Markt vereinbar sind. Daher ist der Käufer, falls er vorhat die genannten Produkte in die USA und/oder in irgendein Nicht-EU-Land zu exportieren, verpflichtet, sich jeweils vorher an die Handelsabteilung des Verkäufers zu wenden, um die Bestätigung zu erhalten, dass das betreffende Produkt allen technischen Erfordernissen und den gesetzlichen Vorschriften entspricht, die zum Schutz des Endverbrauchers in dem jeweiligen Bestimmungsland vorgesehen sind. Der Verkäufer übernimmt dabei keine Verantwortung für vom Käufer ergriffene Initiativen, wenn er nicht vorher darüber in Kenntnis gesetzt worden ist und unabhängig von der eventuellen schriftlichen Genehmigung des Verkäufers zum Export und/oder zur Verwendung des Produkts in einem Nicht-EU-Land.
17. Der Käufer ist verpflichtet, seine Kunden und/oder Endverbraucher über die Eigenschaften des Produkts in Kenntnis zu setzen, um die Gefahr von deren missbräuchlichen Verwendung, die den Verkäufer möglichen Schadensansprüchen aussetzen könnte, auf ein Mindestmaß zu reduzieren. In Ermangelung dieser vorherigen Informationstätigkeit befreit der Käufer den Verkäufer ausdrücklich von jeder möglichen Verantwortung.
18. Die verkaufende Gesellschaft garantiert, dass die Produkte die in der Bestellbestätigung enthaltenen technischen Spezifikationen einhalten, unbeschadet der von der industriellen Fertigung als akzeptabel angesehenen Abweichungen.
19. Die verkaufende Gesellschaft garantiert nicht die Eignung der Produkte zu spezifischen oder Sonderzwecken oder besonderen Verwendungen, außer in dem Fall, wo eine entsprechende Anfrage seitens des Käufers ausdrücklich schriftlich vom der verkaufenden Gesellschaft bestätigt wurde, und dies auf der Bestellbestätigung erwähnt wird. Der Käufer muss sicherstellen, dass eventuell erforderliche spezifische Standards und/oder rechtliche Anforderungen in der entsprechenden Bestellbestätigung seitens der verkaufenden Gesellschaft ausdrücklich enthalten sind.
20. Die von der verkaufenden Gesellschaft gelieferten Informationen zur spezifischen Eignung von Produkten haben reinen Beispielwert.
21. Eventuell von der verkaufenden Gesellschaft geleistete Hilfs- und/oder Berechnungsdienste müssen als reine Orientierungshilfe und als unverbindlich bewertet werden, denn sie liefern eine bloße allgemeine Empfehlung zur Positionierung der Produkte und müssen jedenfalls vom Käufer vollständig geprüft werden; selbstverständlich übernimmt die verkaufende Gesellschaft, da es sich um bloße unverbindliche Empfehlungen handelt, keine Haftung für eventuell aus der inkorrekten oder ungewohnten Anwendung der Produkte entstehende Schäden und/oder Verluste.
22. Da die Anwendung der Produkte seitens des Käufers nicht im Kontrollbereich der verkaufenden Gesellschaft liegen, ist letztere für die tatsächliche Anwendung der Produkte nicht verantwortlich; die verkaufende Gesellschaft übernimmt keine Haftung für eventuell aus der inkorrekten oder ungewohnten Anwendung der Produkte entstehende Schäden und/oder Verluste.
23. Der Widerruf einer Bestellung seitens des Käufers ist nur in Ausnahmefällen und nach schriftlicher Zustimmung der verkaufenden Gesellschaft zulässig.
24. Im Falle der Bestellung von vom Standard abweichenden Produkten und/oder Farben ist der Käufer dazu angehalten, die gesamte eigens dazu hergestellte Produktmenge anzukaufen.
25. Wenn nicht anders abgemacht und unbeschadet des Falls der vorsätzlichen Täuschung, beschränkt sich die Haftung der verkaufenden Gesellschaft für die verkauften Produkte auf einen sich auf das Dreifache des Bestellbestätigungs-Werts belaufenden Betrag, selbst im Falle der schweren Schuld.
26. Sämtliche Streitfragen, die sich im Zusammenhang mit dem Verkauf, sowie sämtlichen Änderungen, einschließlich derer in Bezug auf die Gültigkeit, Wirksamkeit, Auslegung, Durchführung und Auflösung des Vertrags ergeben können, unterliegen der ausschließlichen Zuständigkeit des Gerichtsstands von Mailand (Italien).
27. Auf jeden Fall müssen vor Kauf der Produkte jeweils die Verkaufsbedingungen, die technischen Eigenschaften sowie folgende weitere:

HINWEISE berücksichtigt werden:

- Vor der Installation der Produkte muss die Tragfähigkeit der Wand/des Bodens/der Fläche überprüft werden, an der/auf dem die Produkte angebracht werden sollen, wobei kontrolliert werden muss, ob sie der Art der Benutzer/Verwendung entsprechen, für die sie vorgesehen sind.
- Die Produkte sind nicht für Kinder geeignet.
- Die Produkte sind nicht für die Verwendung im Außenbereich geeignet.
- Die an der Wand/am Boden/ der Fläche montierten Produkte sehen eine Installation mit Verankerungsvorrichtungen vor, die nicht in den Abbildungen des Katalogs gezeigt werden.
- Die Produkte dürfen ausschließlich durch technisches Fachpersonal montiert und/oder installiert werden, wobei jeweils entsprechend geeignete Geräte und Ausrüstung verwendet werden müssen.
- Vor der Montage und Installation der Produkte muss die den Produkten beiliegende Gebrauchsanweisung aufmerksam durchgelesen werden, wobei besonders die Hinweise und die entsprechenden erklärenden Zeichnungen beachtet werden müssen; sollte die Gebrauchsanweisung nicht beiliegen, wenden Sie sich bitte an die technische Abteilung des Verkäufers.
- Um die Produkte an Wand/Boden/Oberflächen zu befestigen, müssen geeignete Beschläge verwendet werden, die in der Lage sind, die auf diese Weise erzeugten Kräfte auszuhalten; auf jeden Fall müssen passende Halterungen verwendet werden, die jedes einzelne Element tragen können.
- Bei nicht vorschriftsmäßiger Installation und/oder im Fall der Überschreitung der in der vorliegenden Preisliste und/oder den jedem einzelnen Produkt beiliegenden Gebrauchsanweisungen angegebenen Höchstlasten könnten sich Gefahrensituationen ergeben, die Produkte könnten kollabieren, nachgeben, herunterfallen und Sach- und/oder Personenschäden verursachen: die angegebenen Lasten daher nie überschreiten.
- Bei Zweifeln in Bezug auf die Art der Installation und/oder die jeweilige Tragfähigkeit der Wand/des Bodens/der Fläche, an der/auf dem das Produkt angebracht werden soll ist, nicht mit der Installation beginnen.
- Halten Sie sich an die in der vorliegenden Preisliste enthaltenen Anweisungen und Zusammenstellungen halten; bei anderweitigen Zusammenstellungen und/oder für nähere Informationen über die Produkte und die Art ihrer Installation wenden Sie sich bitte an die technische Abteilung des Verkäufers.
- Leichte Farbunterschiede zwischen zwei Partien sind unter Wahrung der für Industrieproduktion als zulässig betrachteten Abweichungen als normal zu anzusehen.- Es ist ausschließlich der italienische Text verbindlich, die Übersetzungen dienen lediglich der vereinfachten Lesbarkeit.

I_Caimi Brevetti S.p.A. si riserva, a proprio insindacabile giudizio, la facoltà di modificare senza preavviso i materiali costruttivi, le caratteristiche tecniche ed estetiche, nonché le dimensioni degli elementi illustrati nel presente listino le cui immagini e colori sono puramente indicativi.

EN_Caimi Brevetti S.p.A. reserves, by its unappealable judgment, the right to modify without prior notice the building materials, the technical and aesthetic specifications, as well as the dimensions of the products in this price list, where pictures and colours are purely as an indication.

F_Caimi Brevetti S.p.A. se réserve, à son jugement sans appel, la faculté de modifier sans aucun préavis les matériaux de construction, les caractéristiques techniques et esthétiques ainsi que les dimensions des éléments illustrés dans ce tarif, dont les images et couleurs sont seulement indicatifs.

E_Caimi Brevetti S.p.A. se reserva, a su indiscutible juicio, el derecho a modificar sin previo aviso los materiales de construcción, las características técnicas y estéticas, así como las medidas de los productos del presente lista de precios, donde las imágenes y los colores son meramente indicativos.

D_Caimi Brevetti S.p.A. behält sich das Recht vor, ihrer unkontrollierbaren Meinung nach, verwendete Materialien, technische und ästhetische Änderungen sowie die Abmessungen der in dieser Preisliste abgebildeten Produkte ohne vorherige Ankündigung zu ändern. Die gezeigten Fotos und deren Farben dienen ausschliesslich zur ungefähren Information.

STAMPA
Ingraph Srl

COPYRIGHT
Caimi Brevetti S.p.A. 2024

ARCHIVIO FOTOGRAFICO
Caimi Brevetti S.p.A.

close to people
close to the future